

OCTAVE[®]

ULTRASONIC FLOW METER

FOR GOLD MINES

HIGHLY ACCURATE ULTRASONIC FLOW METER WITH NO MOVING PARTS

FEATURES & BENEFITS

- Double-beam ultrasonic sensors provide highly accurate flow data and reliable operation.
- No impeller or moving parts in the flow path provides for unrestricted, low pressure loss flows.
- Reduced maintenance of wear-prone parts commonly found in other meters.
- Flow ranges from < 1 GPM to 5,500 GPM.
- Multi-line readout screen provides complete flow and volume information along with:
 - Leak detection
 - Battery level
 - Alarms and errors
 - Output mode
 - Active communication mode
- Vacuum sealed and tamper proof IP68 register provides durability and long-term performance.
- Lithium batteries provide a 10 year life expectancy.
- Each meter has a unique, unalterable bar-coded serial number for identification.
- Standard register is programmed to log and display forward flow only (other options available). Physically reversing the meter will not decrease the forward flow totalizer.
- Each meter ships with a certificate verifying flow accuracy with a $\pm 1.5\%$ accuracy for nominal flow rates.



SPECIFICATIONS

- Sizes: 2", 3", 4", 6", 8", 10" and 12"
- Body: Epoxy-coated cast iron with flange inlet and outlet
- Maximum Working pressure: 230 psi
- Fluid Temperature Range: 32° to 122° F (0.1° to 50° C)
- Connection: Flange ANSI ISO
- Power Source: 2 'D' Size non-replaceable Lithium batteries
- Environmental Protection: IP-68, Ambient operation temperature for display: -13 to 131° F (-25° to 55° C)
- Display Units: Multi-line, programmable 9 digit LCD display
- Output (optional): Programmable single/dual open collector pulse output or externally powered 4-20 mA loop

OCTAVE® FLOW METER FOR GOLD MINES

HOW OCTAVE WORKS

The Octave's measurement method is based on an ultrasonic, transit-time, dual-beam sensors that determines the length of time it takes an ultrasonic wave to travel the distance between the two sensors located in the meter's body. The sensors function as both sender and receiver, each one alternating these functions so that the ultrasonic wave travels both with and against the direction of the flow. Because the ultrasonic wave travels slower against the flow than with the flow, the time difference of the two waves allows the meter to determine the flow rate.

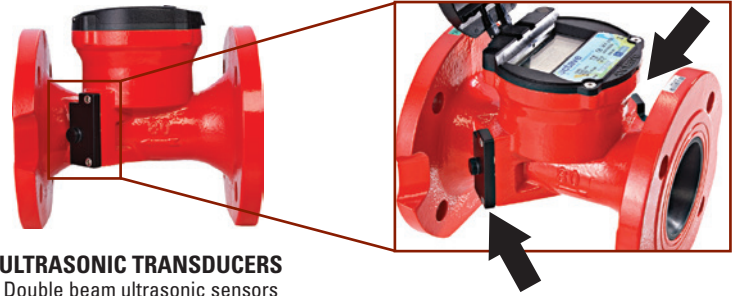

ULTRASONIC TRANSDUCERS
Double beam ultrasonic sensors

OCTAVE PROGRAMMING AND DIGITAL DISPLAY

Multi-line digital LCD readout display provides immediate reporting and visual indicators for critical conditions. The 9 digit display is easy to read at a glance.

Each Octave Meter will be pre-programmed before shipment for an instantaneous flow rate in Gallons per Minute (GPM) and the specified user's requirements for:

- Output Resolution for Optional Pulsed Output

NOTE: Programming software is not available to the end user. Once the meter is programmed, it can only be reset by Netafim.



DIMENSIONS & WEIGHT

SIZE	LENGTH (L)	WIDTH (B)	HEIGHT (H)	HEIGHT (h)	WEIGHT
2"	7.9"	6.5"	7.5"	1.6"	19.8 LBS.
3"	8.9"	7.9"	8.3"	3.5"	28.7 LBS.
4"	9.8"	8.7"	8.8"	4.1"	33.1 LBS.
6"	11.8"	11.2"	11.1"	5.5"	70.5 LBS.
8"	13.8"	13.4"	13.1"	6.5"	99 LBS.
10"	17.7"	15.9"	15.9"	8.0"	150 LBS.
12"	19.7"	19.2"	19.3"	9.6"	216 LBS.

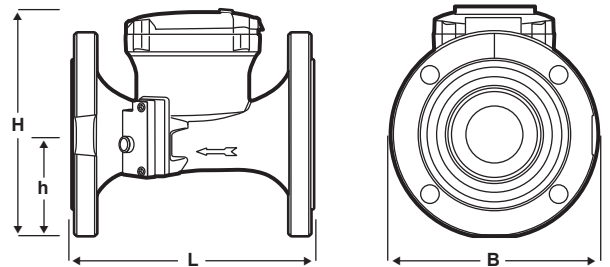

OCTAVE® FLOW METER FOR GOLD MINES

HEADLOSS CURVE - 2", 3", 4" AND 6"

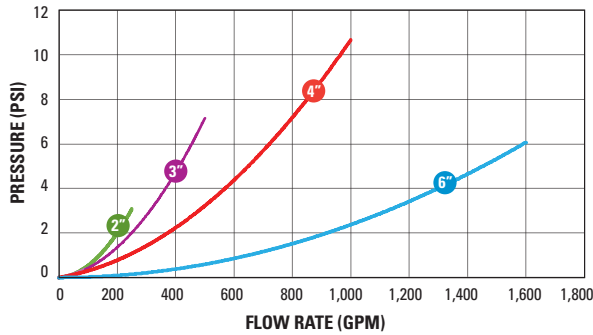

HEADLOSS CURVE - 8", 10" AND 12"

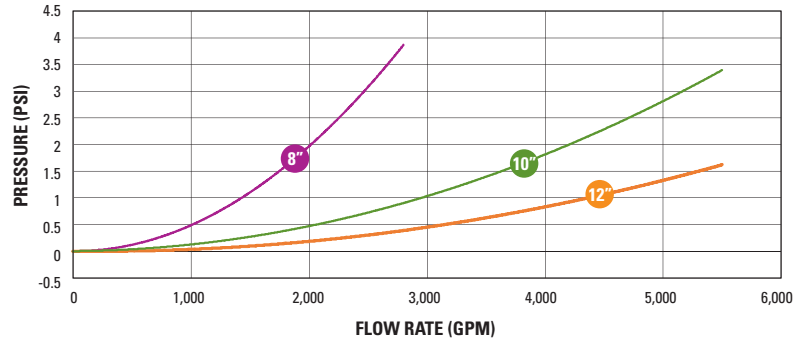

PERFORMANCE DATA

SIZE	EXTENDED LOW FLOW @ ± 5% (GPM)	NOMINAL FLOW RANGE @ ± 1.5% (GPM)	HEADLOSS @ MAX. FLOW RATE (PSI)
2"	0.25	1 - 250	3.1
3"	0.50	1 - 400	6.9
4"	0.75	1 - 650	10.25
6"	2.0	3 - 1,500	6.05
8"	4.0	4.5 - 3,000	3.95
10"	8.0	14 - 5,500	1.75
12"	8.0	14 - 5,500	3.4



OCTAVE'S UNRESTRICTED FLOW PATH

OCTAVE ORDERING GUIDELINES

Standard Features:

- Flow Rate Units: Gallons per Minute (G.P.M.)
- Flow Display: Forward and Reverse Volumes

Options for all Octave Water Meters:

- Pulsed Output Module - Specify the output resolution in Flow Rate Units/Pulse: 0.1, 1.0, 10, 100 or 1,000 U.S. Gallons
- 4-20 mA Output Module (requires an externally powered loop)

The following Programming Options are available by special order only:

- Volume Units: m³ and ft³
- Flow Rate Units: m³/h and L/s
- Flow Display Totalizer: Forward Flow Only and Net Flow (forward flow minus reverse flow)

ORDERING INFORMATION

360CT	SIZE	REGISTER	OUTPUT
	SIZE	REGISTER	OUTPUT
	2" = 02	GALLONS = GAL	NO OUTPUT (METER DISPLAY ONLY) = NO
	3" = 03		0.1 GALLONS PER PULSE = 0.1
	4" = 04		1.0 GALLONS PER PULSE = 1.0
	6" = 06		10 GALLONS PER PULSE = 10
	8" = 08		100 GALLONS PER PULSE = 100
	10" = 10		1000 GALLONS PER PULSE = 1000
	12" = 12		ANALOG OUTPUT 420mA = 420

ORDERING EXAMPLE:

360CT04GAL0.1

4" Octave Water Meter, Volume in Gallons, Flow Rate in Gallons per Minute, Pulse Output 0.1 Gallons per Pulse



OCTAVE WITH OPTIONAL PULSED OUTPUT

OCTAVE® FLOW METER FOR GOLD MINES

INSTALLATION GUIDELINES

The following examples are recommendations for achieving top performance.

- Two (2) diameters of straight pipe are required when installing a 90° elbow before or after the meter. (See Figure 1)
- Two (2) diameters of straight pipe are required when installing the meter upstream or downstream of a valve, tee connection or other source of significant turbulence. (See Figures 2 and 3)

NOTE: The installation of the meter upstream of a pump or large valve is not recommended due to potential cavitation issues.

- Five (5) diameters of straight pipe downstream of a pump (before the meter) and Two (2) diameters of straight pipe downstream of the meter are required. (See Figure 4)

NOTE: When the meter is downstream of the pump, Netafim recommends additional straight pipe to ensure accurate measurements.

- Meter can be installed horizontally or vertically with the water flowing up. It is not recommended for installation where the direction of flow is below the horizontal plane. (See Figure 5)
- To eliminate air in the pipeline and maintain accuracy, use of and proper placement of Air Vents is required. We recommend a Combination Air/Vacuum Release Air Vent or the Pro Air Vent.
- Recommended Air Vent placement: 3" and 4" meters place air vent 12" to 18" before the meter; 6" and 8" meters place the air vent 18" to 24" before the meter; 10" and 12" meters place the air vent 30" to 36" before the meter.
- Installing a Check Valve downstream of the meter creates back pressure to aid in the meter filling with water.

INSTALLATION EXAMPLES

The following illustrations are meter installation examples with Air Vent placement.

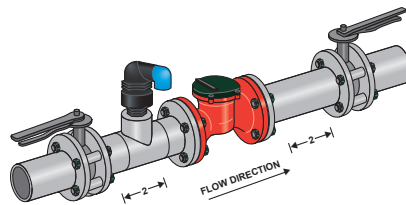
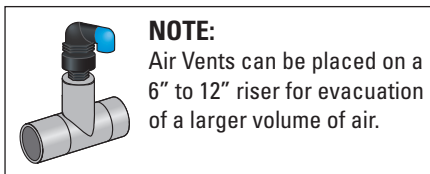

FIGURE 2
(2) PIPE DIAMETERS
BEFORE & AFTER METER

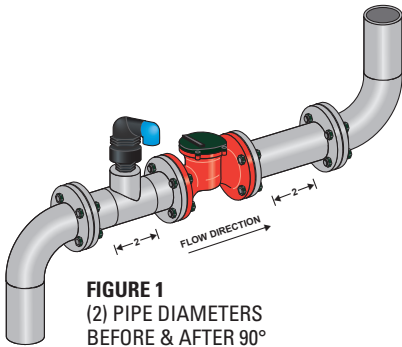

FIGURE 1
(2) PIPE DIAMETERS
BEFORE & AFTER 90°
ELBOWS

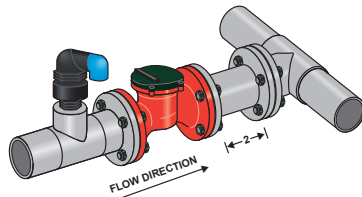

FIGURE 3
(2) PIPE DIAMETERS
BEFORE TEE CONNECTION

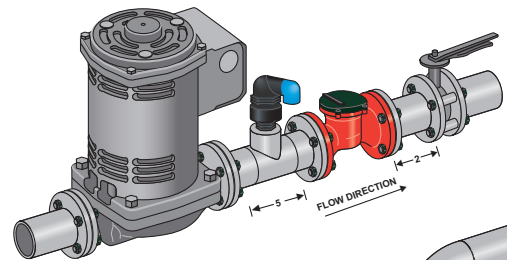
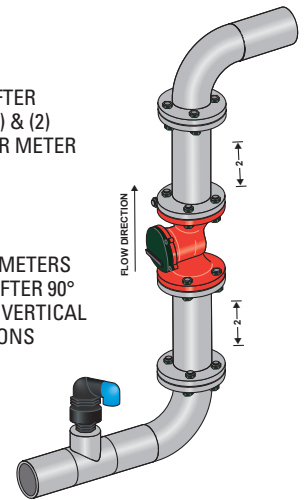

FIGURE 4
(5) PIPE DIAMETERS AFTER
PUMP (BEFORE METER) & (2)
PIPE DIAMETERS AFTER METER

FIGURE 5
(2) PIPE DIAMETERS
BEFORE & AFTER 90°
ELBOWS IN VERTICAL
INSTALLATIONS



NETAFIM USA
5470 E. HOME AVE.
FRESNO, CA 93727
CS 888 638 2346
www.netafimusa.com