

3/4" MANUAL DISC FILTER

INSTALLATION, OPERATION & MAINTENANCE INSTRUCTIONS

FEATURES

- All plastic filter with two 3/4" male connections.
- Filter element consists of grooved discs, mounted on a spine, forming a cylindrical filter element. The discs are compressed together by a spring located at the bottom of the filter cover.
- Screw-on filter cover.
- Resistant to chemicals and liquid fertilizers.
- Available filtration grades: 040, 080, 120, and 140.

TECHNICAL DATA	
FLOW RANGE	1 - 12 GPM
MAXIMUM PRESSURE	140 psi
FILTERING SURFACE AREA	25 sq. in.
FILTERING VOLUME	5.8 cu. in.
LENGTH (H)	5 22/32"
WIDTH (W)	7 15/32"
WEIGHT	.66 lbs.
DISTANCE BETWEEN ENDS (L)	6"
INLET/OUTLET DIAMETER	3/4" Male
MAXIMUM TEMPERATURE	140° F
pH	3-12

MESH/MICRON		
MESH	MICRON	DISC COLOR
040	400	Blue
080	200	Yellow
120	130	Red
140	115	Black

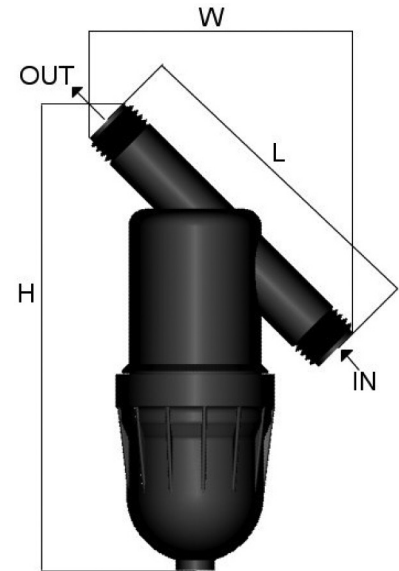

INSTALLATION

1. Use Teflon tape on filter threads - Do Not Use Pipe Dope.
2. Ensure correct inlet/outlet direction.
3. When connecting filter to pipe, do not overtighten.
4. Ensure correct alignment and no undue stress is exerted on the filter body.

MAINTENANCE AND CLEANING

DISMANTLING

1. Ensure system is turned off and no pressure remains in the pipeline.
2. Unscrew cover at bottom of filter.
3. Pull out entire filter element.

CLEANING

1. Move tightening ring to end of spine and flush discs with pressurized water.
2. If discs are not clean after flushing with water:
 - a. If the discs have an accumulation of algae in the grooves, soak the discs and spine in a small bucket of Clorox bleach for one hour and then reflush with fresh water.
 - b. If the discs have an accumulation of iron in the grooves, soak the discs and spine in a small bucket of 10% Muriatic Acid for one hour and then reflush with fresh water. Muriatic Acid can be purchased at any pool supply store.

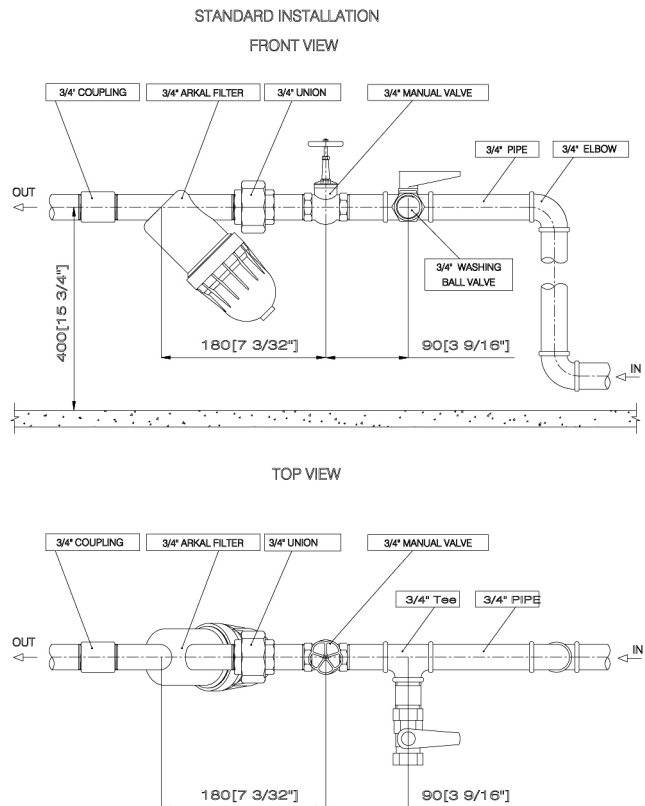

MAINTENANCE AND CLEANING

ASSEMBLY

1. Verify that spring is in place inside the filter cover.
2. Insert filter element and make sure it is seated correctly.
3. Replace cover.
4. Tighten filter cover securely. Do not overtighten.

WINTERIZATION

Drain all the water from the filter to avoid cracking due to freezing.

PARTS BREAKDOWN - 3/4" FILTER

KEY	MODEL NUMBER	DESCRIPTION	MATERIALS
1	25AP230112	FILTER BODY	PBT
2	25AP530140	COVER O-RING	NR
3	25AP530130	COMPRESSION SPRING	SS
4	25AP23013	FILTER COVER	PBT
5	25AP46-***	RING SET WITH SPINE	PP

Substitute *** for proper mesh size.

MATERIALS KEY

CODE	MATERIAL
PBT	POLYESTER
SS	STAINLESS STEEL
PP	POLYPROPYLENE
NR	NITRILE RUBBER

