

FILTRATION

# APOLLO DISC-KLEEN FILTERS

## OPERATION, INSTALLATION & MAINTENANCE GUIDE



**ANGLE CONFIGURATION**



**TWIN CONFIGURATION**

# TABLE OF CONTENTS

Specifications.....	3
Filter Dimensions.....	4
Water Quality & Maximum Flow Rates .....	5
Filter Operation.....	5
Installation.....	8
Filter Start-up.....	10
System Maintenance .....	10
Troubleshooting.....	13
Replacement Parts .....	15

# SPECIFICATIONS

Netafim congratulates you on purchasing the Apollo Disc-Kleen filter. All Netafim filters are easy to install, use and service and don't require special skills to operate. For operation and maintenance of the filter, please follow the instructions in this manual.

## SPECIFICATIONS

	4 UNIT ANGLE	3 UNIT TWIN	3-1 UNIT TWIN	4 UNIT TWIN	5 UNIT TWIN	6 UNIT TWIN	7 UNIT TWIN	8 UNIT TWIN
<b>STANDARD MODEL MAX. OPERATING PRESSURE (psi)</b>	90	90	90	90	90	90	90	90
<b>HIGH PRESSURE MODEL MAX. OPERATING PRESSURE (psi)</b>	140	140	140	140	140	140	140	140
<b>MINIMUM BACKFLUSH PRESSURE (psi)</b>	30	30	30	30	30	30	30	30
<b>FILTRATION SURFACE AREA (sq. in.)</b>	1,625	2,435	1,625	3,245	4,055	4,865	5,675	6,485
<b>BACKFLUSH FLOW PER UNIT (GPM at 35 psi)</b>	95	190	190	190	190	190	190	190
<b>BACKFLUSH VOLUME PER FLUSH CYCLE (GPM)</b>	130	210	210	265	340	420	500	550
<b>INLET/OUTLET MANIFOLD CONNECTION (in.)</b>	10 FL	10 FL	10 FL	10 FL	10 FL	10 FL	10 FL	10 FL
<b>DRAIN MANIFOLD CONNECTION (in.)</b>	4 GR	4 GR	4 GR	4 GR	4 GR	4 GR	4 GR	4 GR
<b>MINIMUM ALLOWABLE PH</b>	5	5	5	5	5	5	5	5

### HIGH PRESSURE MODEL

Dual command filter and orifice plate on drain manifold

### MANIFOLD CONNECTIONS

FL = Flanged and GR = Grooved

## HEADLOSS VS. FLOW RATE

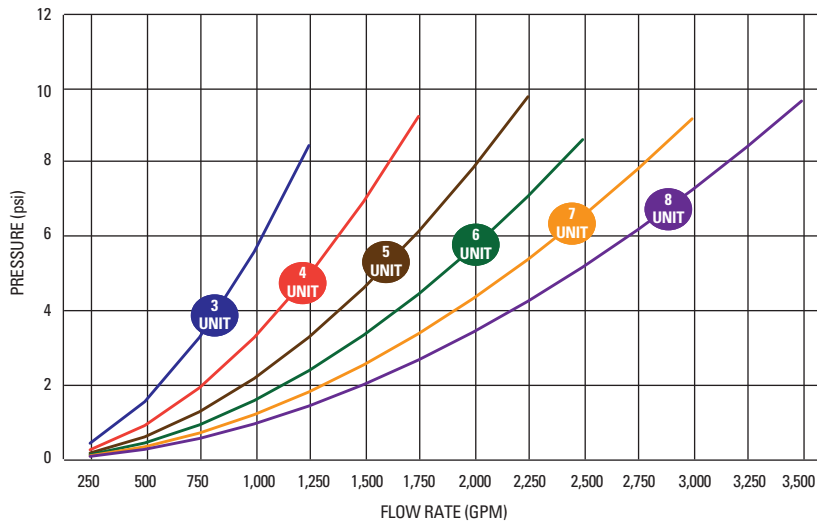

## SOLENOID OPTIONS

TYPE
24VAC
12VDC
12VDCL

## MESH AND MICRON

MESH	MICRON	COLOR
40	400	BLUE
80	200	YELLOW
120	130	RED
140	115	BLACK

# FILTER DIMENSIONS

## MATERIALS

- Manifold: High density polypropylene
- Filter Body and Cover: High density polypropylene
- Discs: Polypropylene
- Backflush Valve: Plastic with reinforced polyamide
- O-Ring and Seals: Rubber

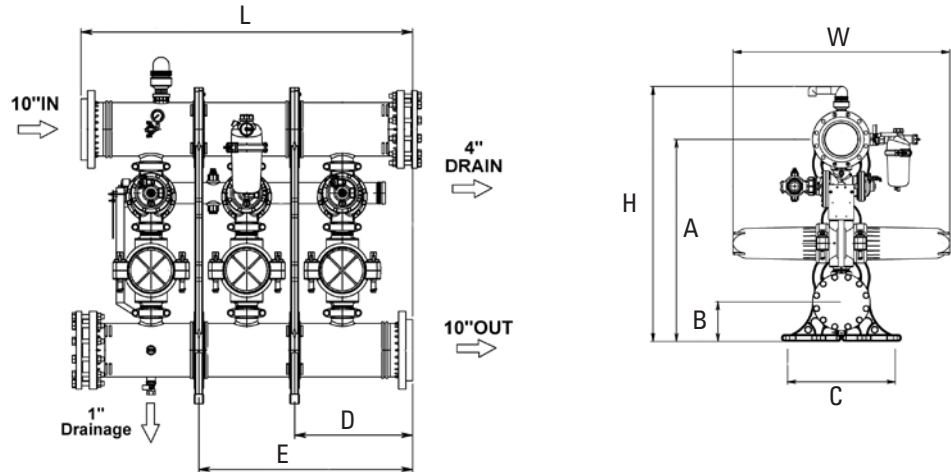

## DIMENSIONS AND WEIGHT

FILTER SIZE	L	W	H	A	B	C	D	E	WEIGHT
4 UNIT ANGLE	64 1/2"	36 1/8"	47 15/16"	-	8 1/4"	-	-	-	510 LBS.
3 UNIT TWIN	68 9/32"	60 9/32"	71 9/32"	56 15/32"	11 1/32"	29 29/32"	24 9/32"	43 31/32"	351 LBS.
3-1 UNIT TWIN	68 9/32"	60 9/32"	71 9/32"	56 15/32"	11 1/32"	29 29/32"	24 9/32"	43 31/32"	235 LBS.
4 UNIT TWIN	87 15/16"	60 9/32"	71 9/32"	45 7/16"	11 1/32"	29 29/32"	24 9/32"	63 31/32"	455 LBS.
5 UNIT TWIN	107 5/8"	60 9/32"	71 9/32"	45 7/16"	11 1/32"	29 29/32"	24 9/32"	63 31/32"	1,254 LBS.
6 UNIT TWIN	127 5/16"	60 9/32"	74 25/32"	47 6/16"	12 1/32"	29 29/32"	24 9/32"	63 31/32"	1,495 LBS.
7 UNIT TWIN	147"	60 9/32"	74 25/32"	47 6/16"	12 1/32"	29 29/32"	24 9/32"	63 31/32"	1,750 LBS.
8 UNIT TWIN	166 11/16"	60 9/32"	74 25/32"	47 6/16"	12 1/32"	29 29/32"	24 9/32"	63 31/32"	2,010 LBS.

All measurements are approximate. For specific dimensions refer to the CAD Design Details located on the Netafim USA website.

# WATER QUALITY & MAXIMUM FLOW RATES

## WATER QUALITY

- **Good Water Quality:** Municipal water supply or well water from a clean aquifer with no sand, iron or manganese.
- **Average Water Quality:** Wells with small amounts of sand (< 2 ppm) or clean surface water which includes lakes, ponds, reservoirs and canals.
- **Poor Water Quality:** Well water from a poor quality aquifer (> 2 ppm) or surface water in hot climates with increased biological growth and no chemical treatment which includes lakes, ponds, reservoirs and canals.
- **Very Poor Water Quality:** Well water with greater than 10 ppm of sand including rivers, muddy canals, lakes and ponds with severe run off deposits and raw municipal wastewater.
- **Greater than 3 ppm Sand or Silt:** May require a pre-filter such as a hydrocyclone.

## SPINES PER FILTER

FILTER SIZE	# OF SPINES
4 UNIT ANGLE	4
3 UNIT TWIN	6
3-1 UNIT TWIN	4
4 UNIT TWIN	8
5 UNIT TWIN	10
6 UNIT TWIN	12
7 UNIT TWIN	14
8 UNIT TWIN	16

## MAX. FLOW RATE (GPM)

WATER QUALITY	FLOW PER SPINE		
	80 MESH	120 MESH	140 MESH
GOOD	198	183	171
AVERAGE	183	171	156
POOR	156	144	132
VERY POOR	132	117	105

### Calculating Maximum Flow Rate (GPM) per Filter Unit:

Take the total # of Spines based on the filter size and multiple that number by the Flow Per Spine based on the Water Quality and Mesh.

The discs are stacked on the spine. The discs are color-coded by mesh size and are selected according to water filtration requirements. The spine assembly has a spring compression unit and an internal piston which are used to alternately compress and release the discs during filtering and backflushing cycles.

### FILTRATION MODE:

During the filtration process the discs are tightly compressed together by the spring, forcing the water to flow through the grooves and traps the debris.

### BACKFLUSH MODE:

During backflush, the discs are separated by the releasing the inlet hydraulic pressure. Multi-jet nozzles provide peripheral spray on the loosened discs, causing them to spin, and release the retained solids, which are flushed out through the drain.

# FILTER OPERATION

FILTRATION MODE

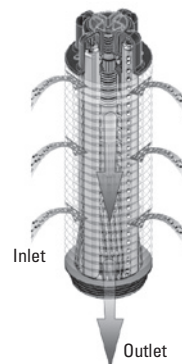

Water flows from outside to inside.

BACKFLUSH MODE

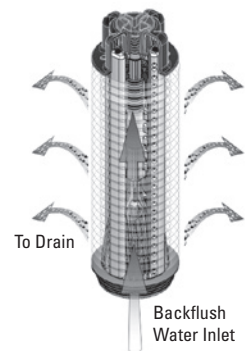

Water sprayed from the inside to the outside.

# FILTER OPERATION

## BACKFLUSH VALVE:

The Backflush valve has two built-in chambers, the N.O. filter port and the N.C. drain port. Each port has its own valve seat, but they share a common shaft and diaphragm. The valve chambers are mutually integrated units. When one port is open, the other is closed, permitting the backflush valve to perform two modes of operation:

## FILTRATION MODE:

The valve permits flow from the inlet manifold through the filter, into the pipeline.

## FLUSHING MODE:

The valve closes the inlet manifold and opens the drain port, causing reverse flow through the filter, ejecting impurities via the drain port. The backflush valve is either controlled by water pressure or a pneumatic source. Operation is initiated by an electric solenoid with a manual override feature. A manual override knob is installed on the base of all AC and DC continuous solenoids. During normal operation, the dot on the round brass knob should be pointing towards the brass solenoid base (down). Turning this knob 90 degrees to the left or right will activate the solenoid and put the valve/filter into a backflush mode. Backflushing should be maintained for 20 seconds, then the knob can be returned to the auto position for normal irrigation. For DC latching solenoids, the manual override green lever is in a vertical position. Turning to the left 90 degrees will put the valve/filter into a backflush mode.

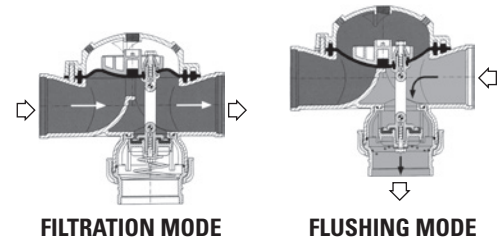

AC & DC CONTINUOUS SOLENOID MANUAL OVERRIDE

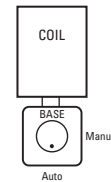

DC LATCHING SOLENOID MANUAL OVERRIDE

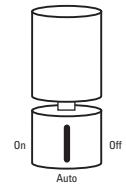

## FILTRATION PROCESS:

During the filtration process, the water flows through the inlet manifold reaching the filters through the backflush valves. The filtered water flows through the outlet manifold into the system.

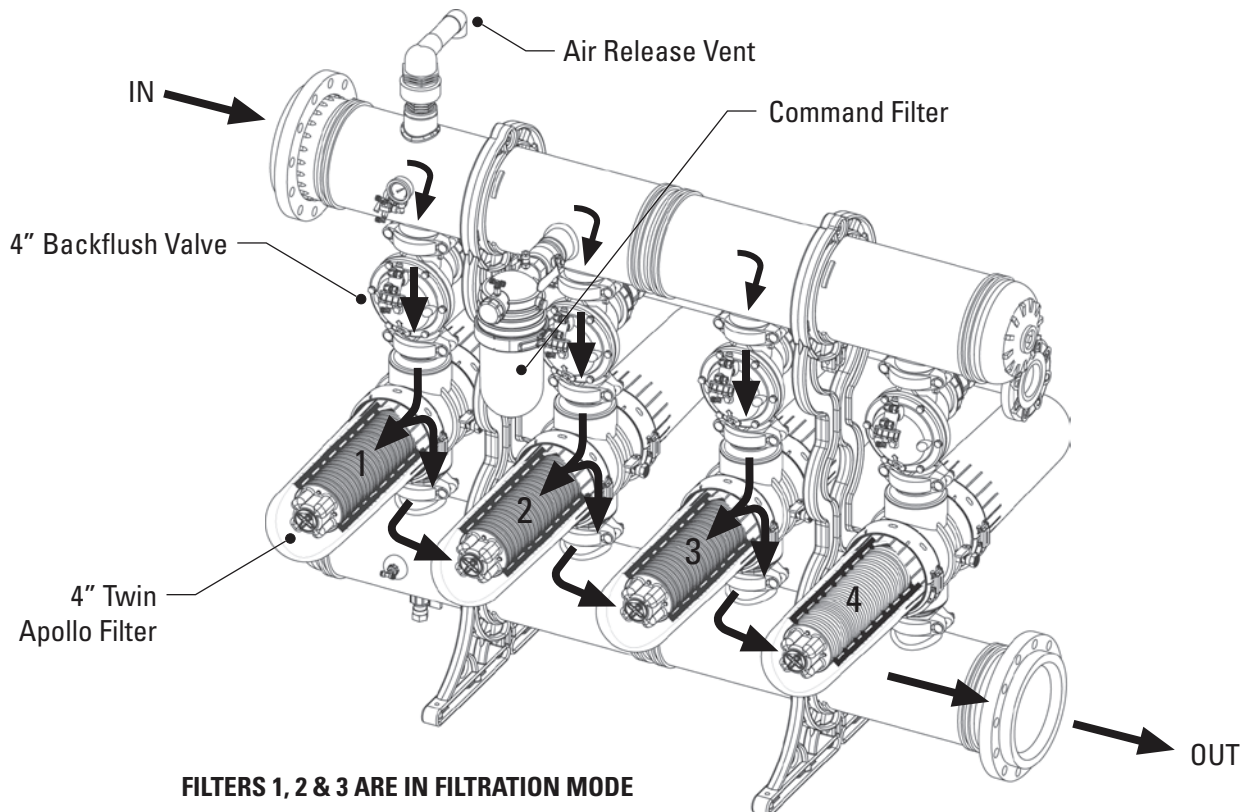

# FILTER OPERATION

## BACKFLUSH PROCESS:

The backflush process begins with an electrical command from the backflush controller to the first solenoid which is activated by the pressure differential gauge or by time.

The solenoid then sends a hydraulic command to the accelerator relay installed on the backflush valve.

The accelerator relay opens causing the No. 1 valve to close the 4" inlet to the filter and open the 3" drain port. Filter No. 1 is now in a backflush position.

The spines in Filter No. 1 operate simultaneously, separating the compressed discs. Jets of clean water supplied by the other filters are sprayed on an angle towards the discs causing them to spin fast and free, flushing trapped solids and debris. The dirty water from this backflushed filter drains out through the drain manifold.

Backflush time per filter is 20 seconds. When the time elapses, the backflush controller stops the electric command to the solenoid. The spines return to the compressed state and the backflush valve closes the drain port and opens for filtration.

The backflush process is repeated for all other filter units. Filters flush one at a time.

After all the filters have been backflushed, the system returns to filtration mode until the next backflush cycle.

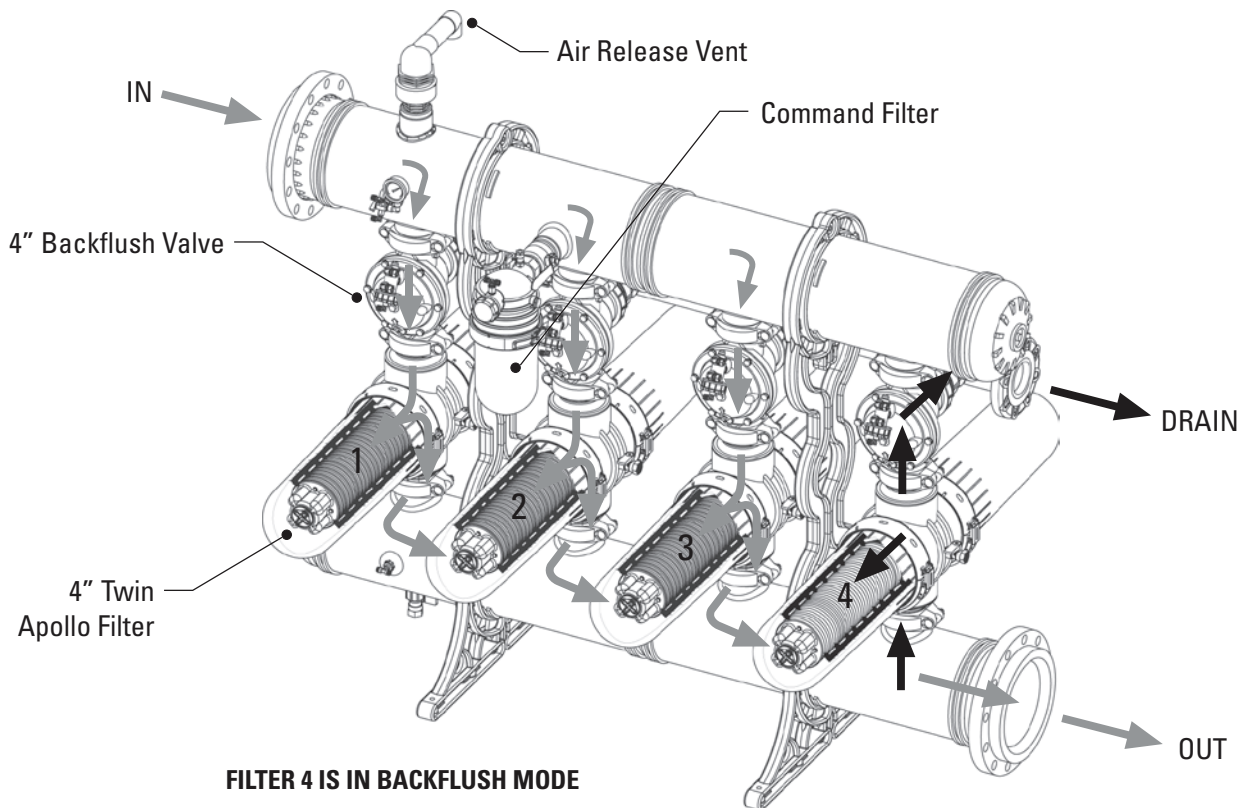

# INSTALLATION

## SAFETY PRECAUTIONS:

Prior to Installation:

1. Take precautions while lifting, transporting or installing the filter.
2. Installation of the filter should be performed so as to avoid direct water splashing on the electronic backflush controller.
3. Confirm that the filter weight, when full, meets the support construction requirements.
4. Prior to installation confirm that line pressure matches filter's operational pressure.
5. During installation, use standard flanges and connections only.
6. Check that all filter flange bolts are properly secured.
7. Please note, the filter enters a flushing mode automatically, without prior warning.
8. Use original parts only when servicing the filter.
9. Netafim cannot accept responsibility for any changes or modifications to the equipment.

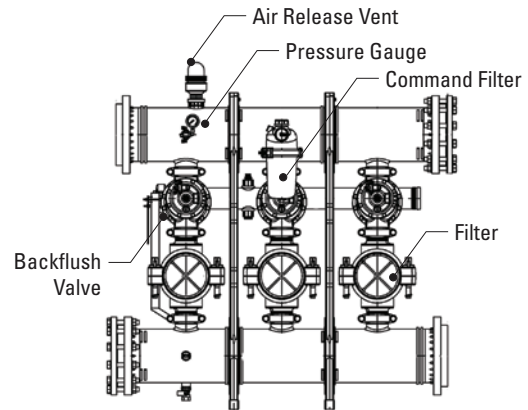

### PLEASE NOTE:

Before opening the filter clamp, check that there is no pressure in the filter. Open the 1" brass ball valve found on the side of the filter body to release any pressure in the filter.

## INSTALLATION:

- Make sure that the inlet and outlet orientation is correct (shown by arrows on filter).
- Prior to start-up, check for any damage to the unit.
- Connect backflush drain manifold.
- Cover clamps need to be properly closed with safety pins secured.
- Verify the solenoids are correct as ordered before connecting the wires to the backflush controller.

## DRAIN MANIFOLD INSTALLATION:

### DRAIN MANIFOLD INSTALLATION GUIDELINES

Minimum Battery Pressure Downstream	30 psi
Backflush Flow Rate	190 GPM
Drain Pipe Diameter	4"
Topographic Elevation	0

### PLEASE NOTE:

- If the drain manifold is over 50' in length, a 6" diameter drain pipe is recommended. This will eliminate back pressure to the filter during the backflush mode.
- If there is positive elevation of the drain manifold, the pressure required for backflush will increase. For every 2.3 feet of elevation, an additional 1 psi must be added to the minimum downstream pressure of 30 psi.

## BACKFLUSH CONTROLLER ELECTRICAL WIRE HOOK-UP:

- Use 1/2" conduit and 16 gauge wire or larger from the controller to the solenoids.
- C is common to all solenoids 24 VAC or 12 VDC. For the 12 VDCL (latching), use positive or red lead.
- M is master valve – used with Pressure Sustaining Normally Open or Electric valves to control the downstream flow.
- Terminals 1-8 for each solenoid for the "hot" lead.
- Seal the wire access holes to the controller.

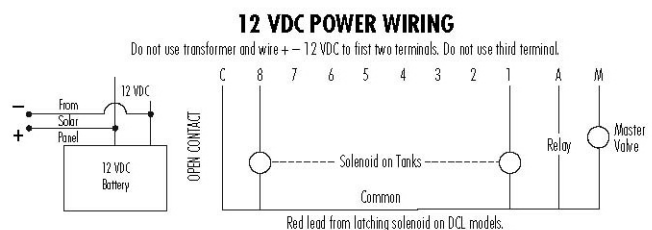
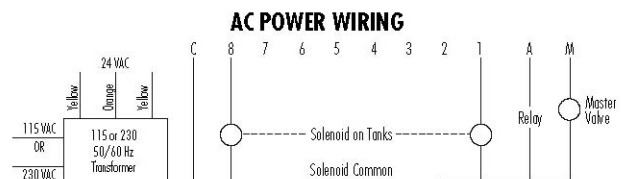



# INSTALLATION

**NOTE: Refer to Netafim USA's YouTube Channel for Backflush Controller Installation Video**

## BACKFLUSH CONTROLLER INSTALLATION:

- Refer to the controller's handbook for installation instructions.
- Make sure that the voltage of both the solenoid unit and controller are correct.
- Set the backflush controller switch to "RUN".
- Check that the PD hydraulic switch HIGH and LOW pressure lines are correctly connected to the appropriate ports. The high pressure sensing port is found on the last backflush valve. The low pressure sensing port is found on the downstream outlet manifold.
- Set the starting backflush point on the PD switch to: 5 psi differential when flushing at 30 psi  
7 psi differential when flushing at 40 psi or greater
- Set the controller to a flush time of 20 seconds and a dwell time of 10 seconds. These settings may require adjustment to conform to local water conditions. Typically, a 2 to 4 hour interval between backfluses is recommended.

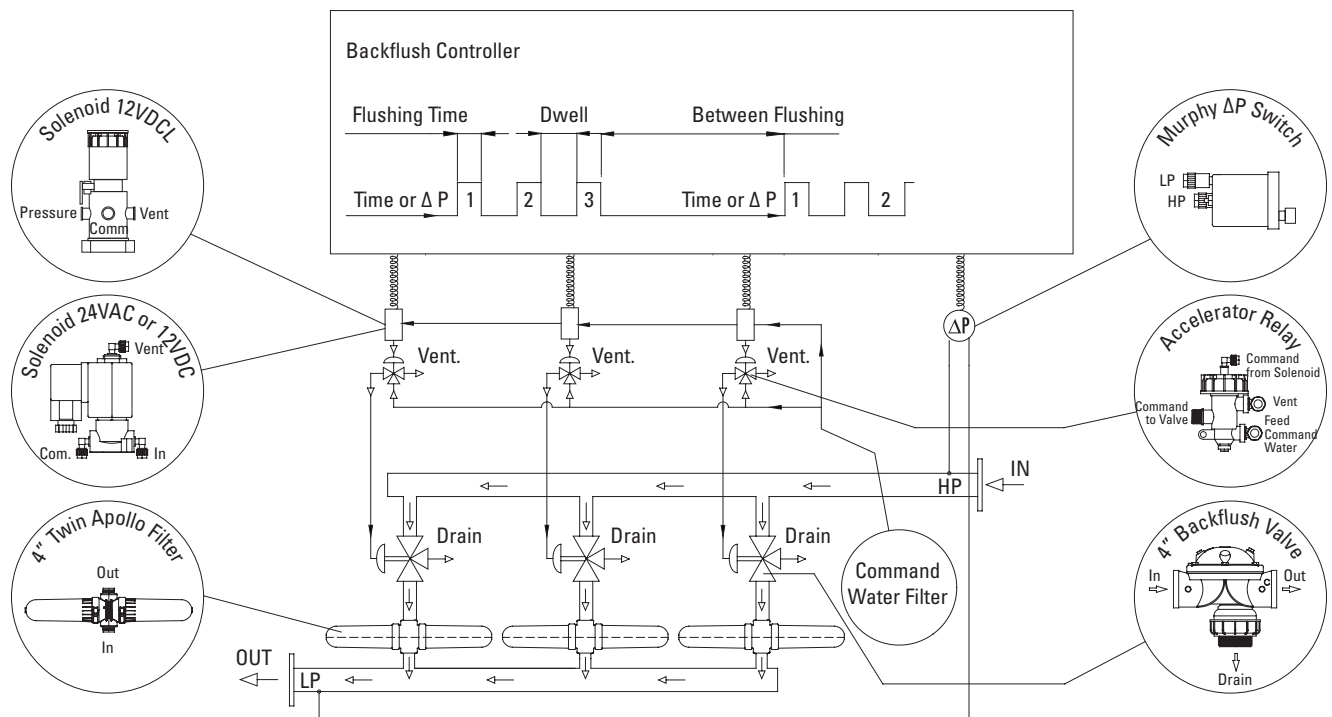

# FILTER START-UP

**NOTE: Refer to Netafim USA's YouTube Channel for Apollo Filter Start-Up Video**

## START-UP OPERATION:

- Flush out the main line upstream of the filter by opening the blind flange connection of the inlet manifold. After initial flushing, reassemble the blind flange.
- Turn the system on slowly to build up the pressure.
- Start the backflush cycle making sure that all system components function correctly.
- Check that the PD gauge reads zero after a backflush cycle.

## IF FILTER LOADS UP DURING START-UP:

- Close the downstream (flow control) valve to increase pressure downstream of the filter.
- Initiate backflush cycle until the discs are clean.
- Slowly reopen the downstream valve.
- If the pressure difference remains high, check and see if the flow rate is too high. An excessive flow rate through the filter causes excessive pressure loss.

# SYSTEM MAINTENANCE

## GENERAL REQUIREMENTS AND MAINTENANCE:

- Confirm there is 30 psi of pressure downstream of the filter during backflush.
- Check that the Pressure Differential (PD) Gauge returns to 0-2 psi after a backflush.
- All vent tubes need to vent freely to atmosphere without any back pressure.
- To minimize damage to the backflush controller, always keep the door closed and turn off the power when not using the controller for long periods of time.

## SEASONAL MAINTENANCE:

- At the end of the irrigation season, just before shutdown, initiate a backflush with the required pressure and turn off the water. This will ensure the discs remain clean during the offseason.
- Manually clean the discs if needed – see detailed instructions on Page 11.
- In order to prevent the filter from becoming damaged under freezing conditions, drain all the water from the filter and leave the drain valve open. Disconnect the hydraulic tubes from the PD Gauge.

## WEEKLY CHECK

<input checked="" type="checkbox"/>	Inlet/Outlet Pressure
<input checked="" type="checkbox"/>	Backflush Controller
<input checked="" type="checkbox"/>	Leakage
<input checked="" type="checkbox"/>	Clean Command Filter

## MONTHLY CHECK - OPERATE BACKFLUSH IN THE SYSTEM ACCORDING TO DP METER AND CHECK:

<input checked="" type="checkbox"/>	Solenoids
<input checked="" type="checkbox"/>	Downstream Pressure and Drain
<input checked="" type="checkbox"/>	Backflush Valves

# SYSTEM MAINTENANCE

**NOTE: Refer to Netafim USA's YouTube Channel for Apollo Disc Cleaning Video**

## **PLEASE NOTE:**

- Make sure the system is not under pressure.
- Before removing the cover you may experience the vacuum phenomenon which will make removing the cover very difficult or almost impossible.
- DO NOT insert any sharp tools or objects in between the cover and the body. You may damage the hydraulic seal and the cover.
- In order to remove the cover easily, you should drain the water from the filter.
- You may drain the filter through the drain valve located on the filter body. Once the filter is empty, the cover can then be removed safely and easily.

## **DISC CLEANING INSTRUCTIONS:**

- Use the clamp wrench to loosen the bolts.
- Slide the clamp down and off the filter.
- Remove the filter cover from the filter body.
- Unscrew the butterfly nut on the filtration element.
- Remove the tightening cylinders.
- Remove the discs. For convenience, we recommend using a plastic bag.
- Tie each disc set on a string and place them in a cleaning solution. Refer to instructions on page 12 for recommended cleaning solutions based on water deposits.
- Thoroughly wash the discs with fresh water and then reassemble the discs on the spine.
- Check that the correct quantity of discs is assembled on the spine. When the discs are pressed with two hands, the top disc should be level with the imprinted white line on the outside of the spine.
- Replace the tightening cylinder and tighten the butterfly nut until it stops - do not overtighten.
- Ensure the cover O-ring is in the correct position with the holes facing out.
- Place the filter cover on the filter body and secure it with a slight clockwise rotation. Reposition the clamp onto the cover and tighten the bolts with the clamp wrench.

# SYSTEM MAINTENANCE

**NOTE: Refer to Netafim USA's YouTube Channel for Apollo Disc Cleaning Video**

## **DISC CLEANING INSTRUCTIONS FOR SURFACE WATER WITH ORGANIC AND BIOLOGICAL RESIDUE:**

### **STEP 1**

- Make a 10% Peroxide solution. Pour 1.8 gallons of water into a container and add .80 gallons of Hydrogen Peroxide (35%) or pour 2.1 gallons of water into the container and add .53 gallons of Hydrogen Peroxide (50%) to the water.
- Soak the discs in this solution making sure the discs are loose and have good contact on both sides with the Peroxide solution. Do not put too many discs in at one time.
- Stir the discs in the solution a few times.
- Total soaking time is 1 to 3 hours. If the solution is no longer cleaning the discs, replace it with a new mixture.
- Remove the discs and rinse well with water – there should only be a pale sedimentation on the discs.

### **STEP 2**

- After the discs have been rinsed with water, they must be soaked in a 10% Hydrochloric Acid solution to remove the organic residue.
- Make a 10% Hydrochloric Acid solution. Pour 1.8 gallons of water into a container and add .80 gallons Hydrochloric Acid (30-35%) to the water.
- Soak the discs in this solution making sure the discs are loose and have good contact on both sides with the acid solution. Do not put too many discs in at one time.
- Stir the discs in the solution a few times.
- Total soaking time is 1 to 3 hours. If the solution is no longer cleaning the discs, replace it with a new mixture.
- Remove the discs and rinse well with water – there should no longer be any residue between the grooves of the discs.
- Put the discs on the spine and spine assembly in the filter bank.
- Flush the filter bank a few times to remove all chemicals.

## **DISC CLEANING INSTRUCTIONS FOR WELL WATER WITH MANGANESE, IRON OR CARBONATE DEPOSITS:**

### **STEP 1**

- Make a 10% Hydrochloric Acid solution. Pour 1.8 gallons of water into a container and add .80 gallons Hydrochloric Acid (30-35%) to the water.
- Soak the discs in this solution making sure the discs are loose and have good contact on both sides with the acid solution. Do not put too many discs in at one time.
- Stir the discs in the solution a few times.
- Total soaking time is 1 to 3 hours. If the solution is no longer cleaning the discs, replace it with a new mixture.
- Remove the discs and rinse well with water – there should only be a pale sedimentation on the discs.

### **STEP 2**

- After the discs have been rinsed with water, they must be soaked in a 10% Peroxide solution to remove the organic residue.
- Make a 10% Peroxide solution. Pour 1.8 gallons of water into a container and add .80 gallons of Hydrogen Peroxide (35%) or pour 2.1 gallons of water into the container and add .53 gallons of Hydrogen Peroxide (50%) to the water.
- Soak the discs in this solution making sure the discs are loose and have good contact on both sides with the Peroxide solution. Do not put too many discs in at one time.
- Stir the discs in the solution a few times.
- Total soaking time is 1 to 3 hours. If the solution is no longer cleaning the discs, replace it with a new mixture.
- Remove the discs and rinse well with water – there should no longer be any residue between the grooves of the discs.
- Put the discs on the spine and spine assembly in the filter bank.
- Flush the filter bank a few times to remove all chemicals.

**CAUTION:** When blowing out with compressed air, make sure all parts are opened.

# TROUBLESHOOTING

**NOTE: Refer to Netafim USA's YouTube Channel for Apollo Troubleshooting Guide Video**

## **NO WATER GOING THROUGH THE FILTER:**

- If the system has upstream and downstream valves around the filter, check to make sure they are open. Check that field valves are open.
- At start-up, the backflush valves need a minimum 12 psi to start working. If air is trapped in the system, close the downstream butterfly valve so that pressure builds up at the filter. Then, slowly open the butterfly valve to allow water to flow to the field.
- Verify that the manual override buttons on all the solenoids are in the correct position. For AC and DC continuous solenoids, the dot in the round brass knob should be pointing towards the brass base of the solenoid, not towards the black square plastic solenoid coil. For DC latching solenoids, the green lever should be vertical. See page 6 for illustrations. If all of the manual override buttons are in the wrong position, water will not flow through the filter.
- Make sure all vent tubes are venting to atmosphere with no back pressure.

## **NO BACKFLUSH OPERATION:**

### **Check the Upstream and Downstream Pressure**

- The pressure downstream of the filter needs to be at least 30 psi during backflushing. The Pressure Sustaining Normally Open (PSNO) Valve should be set to at least 30 psi during backflushing.

### **Check the Command Filter**

- Make sure the command filter is clean. A clogged command filter does not provide command water to the solenoids and backflush valves and the filter will not flush. Also, make sure the 2" ball valve in front of the command filter is open.

### **Check the Pressure Differential (PD) Gauge**

- Make sure the PD gauge is not broken. The set point (the short needle) should be set at 5 psi. The long red needle indicates the pressure differential at any given time. If the needle reads zero, then the discs are clean. As the red needle moves towards the shorter (set point) needle, then the discs are getting dirty. When the two needles touch, the backflush controller will initiate a flush cycle.
- Test the PD gauge while the water is on - disconnect the hydraulic tube from the low pressure port of the gauge (the off center port). Water will squirt out of the tube; you can bend the tube to temporarily stop the water. The long red needle should move quickly and touch the short needle. When both needles touch for 15 consecutive seconds, a backflush cycle will start.
- If the backflush starts, then the PD gauge is working. If there is no flush, replace the PD gauge. Re-connect the hydraulic tube to the PD gauge.

### **Check if the Filter Discs are Clogged**

- To check if the filter discs are clogged, turn off the water and confirm there is no pressure in the system. Open up a filter cover and inspect the discs. If all of the filters are completely clogged, the filter will not flush.
- Remove the discs and clean – refer to the Disc Cleaning Instructions on Page 11 and 12.
- Reassemble the discs on the spine and the filter cover, then tighten the clamp.
- Initiate a backflush with the backflush controller. If the filter still doesn't flush, refer to the Check the Backflush Controller Section below.

### **Check the Backflush Controller**

- To test the backflush controller, initiate a backflush by pressing the black button (manual override).
- The solenoid should click and send the filter into flush mode. After 20 seconds, the solenoid should click again and end the backflush.
- If the solenoid clicks, then the solenoid is operating and the control panel is not. If the solenoid does not click, then the solenoid needs to be replaced
- To test the solenoids: remove the wires of the solenoid from the terminal of the control panel and connect them directly to the power source. For DC models, touch the wires. For AC models, connect the solenoid wires to the outlet transformer wires.
- If the backflush was not initiated, check wires to verify all connections are secure.
- Push the reset button on the front panel and initiate a backflush again.
- Flush a filter individually by turning the manual override of the solenoid 180 degrees. If that filter flushes, then the filter is working hydraulically and the problem is electric.

# TROUBLESHOOTING

**NOTE: Refer to Netafim USA's YouTube Channel for Apollo Troubleshooting Guide Video**

## **CHECK THE BACKFLUSH CONTROLLER (CON'T)**

- For AC backflush controllers, make sure the transformer is still functioning and replace if needed.
- The controller panel can malfunction if exposed to moist or dusty conditions, rust, or lightning. If you suspect any of these causes, contact the backflush controller manufacturer for inspection and possible warranty or repair. Or call Netafim USA Technical Support for assistance.

## **CONTINUOUS BACKFLUSHING:**

### **Constant Water Flowing Out of the Drain Manifold**

- If there is constant water going through the drain manifold, then one of the backflush valves is stuck in the flush position. This can be caused by one of these three issues:
  - There may be debris stuck in the drain port of the backflush valve which does not allow the valve to return to the filtration position. Determine which valve is flushing all of the time. Turn the manual override of the solenoid to flush and then return the knob to filtration. Make sure the knob is in exactly the correct position. If the valve is still flushing, turn off the water.
  - Remove the entire 4" drain manifold from the back of the backflush valves. Visually inspect the back side of all valves to see if there is debris. Start to disassemble the backflush valve from the back by removing the large plastic union. Put the large spring or large o-ring in a secure place. Remove the small bolt from the stem, pull out the black round piece and remove any debris. Carefully reassemble the valve and attach the drain manifold.
  - The solenoid may be stuck and not returning to filtration mode. On the Backflush Controller, switch the terminal wire (the wire connected to terminal 1 and 2 for example) from a stuck solenoid to a working solenoid. If the problem moves with the solenoid that is stuck, then the problem is in the solenoid. Disassemble the solenoid to clean any debris. If the problem persists, replace the solenoid coil with a new one.
  - The diaphragm of the backflush valve may be torn. To confirm, close the ball valve in front of the 2" command filter. If water is still flushing from the drain manifold, the diaphragm may be torn. Turn off the water and remove all of the bolts from the bonnet of the valve. Remove the diaphragm and inspect for tear. Replace if necessary.

### **Filter Completes a Backflush Cycle, Stops and Backflushes Again:**

- If the filter is constantly backflushing by going through a cycle, stopping for 1 minute and backflushing again, look at the controller to see if the word "Alarm" is flashing. If it is, then the filter is probably clogged.
- The filter will get clogged for the following reasons:
  - There was less than 30 psi on the downstream side of the filter during backflush.
  - The water quality changed and became too dirty for the filter to keep up. (Check for severe algae bloom or high silt load).
  - The flow rate was increased by turning on an additional valve, so the filter cannot keep up with the increased flow rate.
  - The diameter of the drain pipe is too long or too small or it's plumbed so that it elevates back into a reservoir. All of these will create back pressure on the filter during the flush cycle and have a negative effect on the quality of the flush. The drain pipe should be at least 4" diameter, not to exceed 50 feet long and free flow to a drain pit. If the drain pipe needs to be longer than 50 feet, use a 6" pipe. There should not be a check valve or gate valve on the drain pipe.
  - Remove the discs from the spines and clean them manually. Refer to the Disc Cleaning Instructions on Pages 11 and 12.

# REPLACEMENT PARTS

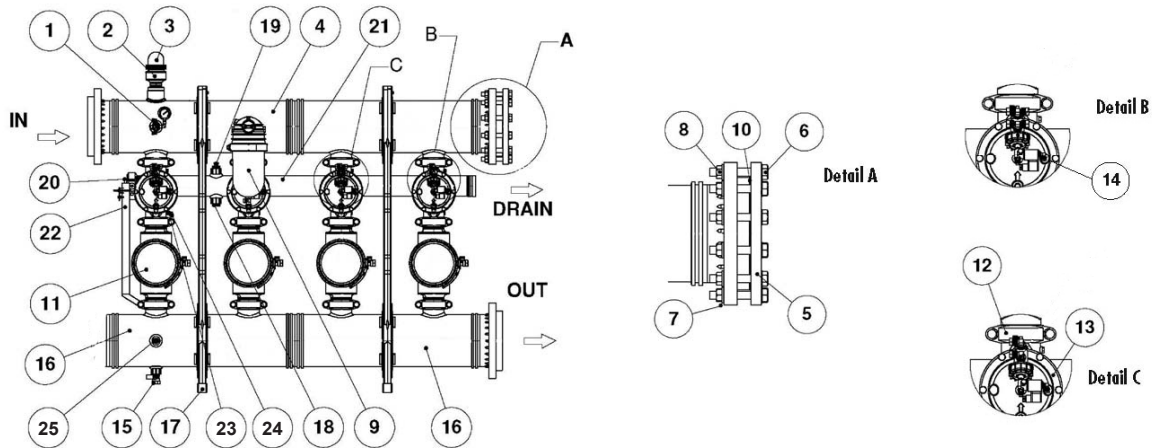

## APOLLO DISC-KLEEN FILTER BATTERY PARTS

Model Numbers 26ASK\*PP or 26ASK\*PPB and the NEW Modular Apollo 26SK\*PB

Key	Item Number	Model Number	Description	Price Each
1	-	25AP225403414	Pressure Gauge Assembly	228.00
2	70561-001660	65ARIB2PP	2" Combination Air Vent	208.00
3	-	25AP50480222	Extension for Combination Air Vent	48.00
4	-	-	Inlet Manifold	Call
5	00110-001520	25APMODBLINDFLG-P	Blind Flange	830.00
6	-	25AP50402139	7/8" Bolt for Blind Flange	23.00
7	-	25AP50409017	7/8" Washer for Blind Flange	2.40
8	-	25AP50408017	7/8" Nut for Blind Flange	9.10
9	70641-003640	25A30-120	2" Dual HP Command Filter	489.00
10	00110-001521	25APMODGASKET	Gasket for Blind Flange	41.00
11	-	25AP14461***	Apollo 4" Twin Filter	6,222.00
	-	25AP13761***	Apollo 3" Angle Filter	3,350.00
12	70040-003100	44VIC04	4" Victaulic Coupling	62.00
13	71000-013440	61BFG4GPGB-DM	4" Series 350 Plastic Backflush Valve	1,308.00
	71000-013360	61BFG3PB	3" Series 350 Plastic Backflush Valve (Angle Filter Only)	821.00
14	70800-003260	61BBC-024	24VAC Normally Closed Solenoid	201.00
15	76601-001400	62SBV100F	1" Ball Valve	65.00
16	-	-	Outlet Manifold	Call
17	-	25AP22531001	Plastic Support Leg for 10" Inlet/Outlet Manifolds	800.00
	-	25AP22531210	Plastic Support Leg for 12" Inlet/Outlet Manifolds	864.00
18	75050-008500	595177100	1" Plug	2.50
19	70620-008360	25AP22530512	1/2" Vacuum Breaker on Drain Manifold	21.00
20	78201-010100	44VICCP04	4" Victaulic Cap	27.00
21	-	-	Drain Manifold	Call
22	70041-004000	25AP22541230	Mounting Bracket for Backflush Controller	113.00
23	71680-014170	61SF25P	Plastic Finger Filter	17.00
24	76400-003410	55P4694802-B	Plastic Elbow 8 mm x 1/8" M for Solenoid & Relay (Bag 10)	45.70
25	76400-004505	55P4714804-B	Plastic Male Branch Tee 8 mm x 1/4" x 8 mm (Bag 10)	57.80
-	00110-001540	25APMODKITFLNG	Flange-Bolt Kit: 24 bolts, 24 nuts, 48 washers, 2 flanges	1,988.00
-	00110-001550	25APMODKIT5-8	Adapter Kit: 24 bolts, 24 nuts, 48 washers, 1 drain manifold, 1 conn.	786.00
-	76400-005410	55P1210400-B	1/4" Plug (Bag 10)	8.80
-	40001-000382	15CONT8C50	8 mm Control Tube (50' Roll)	9.00

Model Numbers will be different based on filter configurations.

**NOTE:** Substitute \*\*\* with desired mesh.

# REPLACEMENT PARTS

## APOLLO DISC-KLEEN FILTER PARTS

Twin Filter

Key	Item Number	Model Number	Description	Price Each
1	70620-003432	25AP22000402	4" Twin Body	709.00
2	76000-002400	25AP50540112	3/4" Ball Valve	32.00
3	70620-007065	25AP50032311	O-Ring for 3/4" Ball Valve	6.20
4	70620-005100	25AP50060004	Gauge Port Seal	8.40
5	70620-005200	25AP25110103	Gauge Port Nut	5.90
6	70620-004300	25AP534341	Cover Gasket	25.00
7	70620-019450	25AP700190003658	Clamp - Polymeric Complete	263.00
8	70620-004146	25AP50022355	Spine Seat O-Ring	7.20
9	-	25AP20334-***	Ring Set Only	358.00
10	70620-007414	25AP21991040LC	Spine Assembly without Rings	1,534.00
11	70620-002162	25AP25010602	Filter Cover	421.00
12	70620-019460	25APLCLPWRENCH	Wrench for Polymeric Clamp Bolts	6.60
13	70620-007900	25AP50760028	Butterfly Nut Wrench	47.00

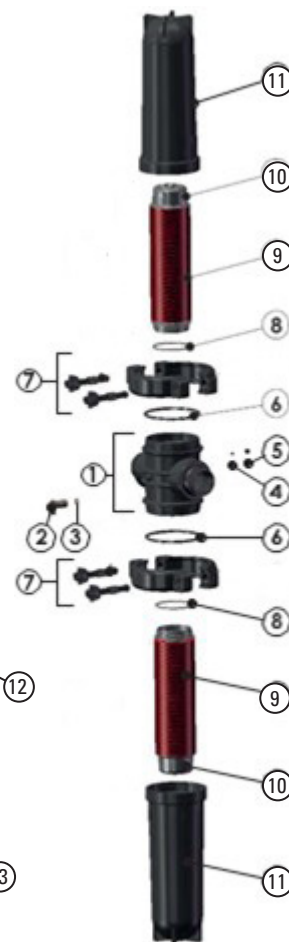

## APOLLO DISC-KLEEN FILTER PARTS

Angle Filter

Key	Item Number	Model Number	Description	Price Each
1	70620-003384	25AP22371011	3" Angle Body	361.00
2	70620-003865	25AP50540212	1/4" x 1/2" Ball Valve	34.00
3	70620-005100	25AP50060004	Gauge Port Seal	8.40
4	70620-005200	25AP25110103	Gauge Port Nut	5.90
5	70620-004300	25AP534341	Cover Gasket	25.00
6	70620-019450	25AP700190003658	Clamp - Polymeric Complete	263.00
7	70620-004146	25AP50022355	Spine Seat O-Ring	7.20
8	-	25AP20334-***	Ring Set Only	358.00
9	70620-007414	25AP21991040LC	Spine Assembly without Rings	1,534.00
10	70620-002162	25AP25010602	Filter Cover	421.00
11	70620-007900	25AP50760028	Butterfly Nut Wrench	47.00
12	70620-019460	25APLCLPWRENCH	Wrench for Polymeric Clamp Bolts	6.60

NOTE: Substitute \*\*\* with desired mesh.



**NETAFIM USA**  
 5470 E. Home Ave.  
 Fresno, CA 93727  
 CS 888 638 2346  
[www.netafimusa.com](http://www.netafimusa.com)