

SAP DESCRIPTION:

NC 480610 C

SKU No.

Maximum Flow Rate: 2244 GPM

Recommended Flow Rate: 1848 GPM

Inlet Pressure: 115 PSI

Sheet Size:

A4

Scale:

1:35

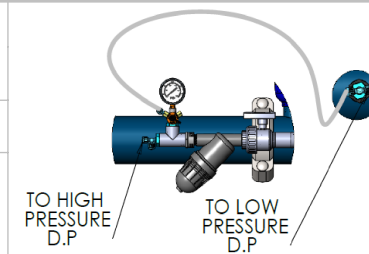

PROPRIETARY AND CONFIDENTIAL
THE INFORMATION CONTAINED IN THIS DRAWING IS THE SOLE PROPERTY OF NETAFIM. ANY REPRODUCTION IN PART OR AS A WHOLE WITHOUT THE WRITTEN PERMISSION OF NETAFIM IS PROHIBITED

Designed By: KEREM 28/04/2021

Drawn By: KEREM 28/04/2021

Checked By:

QA

Sheet: 1 Of: 3 Rev. -

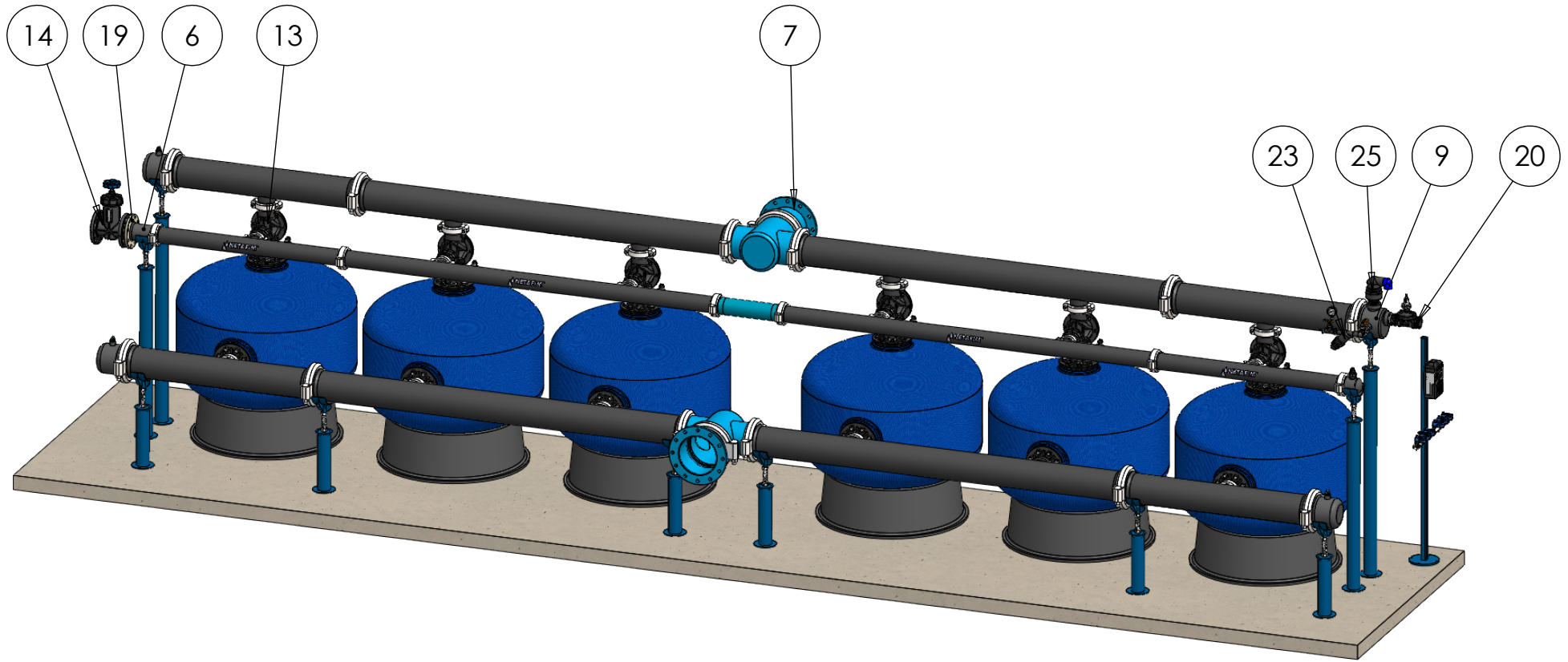

SAP DESCRIPTION:

NC 480610 C

SKU No.

Maximum Flow Rate: 2244 GPM

Recommended Flow Rate: 1848 GPM

Inlet Pressure: 115 PSI

Sheet Size: A4

Scale: 1:40

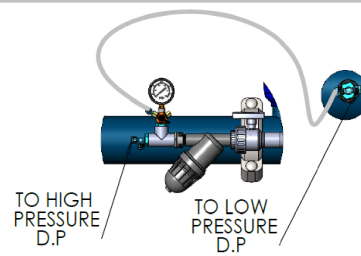

PROPRIETARY AND CONFIDENTIAL
 THE INFORMATION CONTAINED IN THIS DRAWING IS THE SOLE PROPERTY OF NETAFIM. ANY REPRODUCTION IN PART OR AS A WHOLE WITHOUT THE WRITTEN PERMISSION OF NETAFIM IS PROHIBITED

Designed By: KEREM 28/04/2021

Drawn By: KEREM 28/04/2021

Checked By:

QA

Sheet: 2 Of: 3 Rev. -

ITEM NO.	SAP Description	SAP Cat. No.	QTY.
1	SANDSTROM NC TANK 48"X4" VIC	71920-003210	6
2	PE MAN 8"*2 OUT*4" VIC F/48" TANK	71920-002070	4
3	PE MAN 8"*1 OUT*4" VIC F/48" TANK	71920-002060	4
4	PE BF MAN 4"*2 OUT*3" VIC F/48" TANK	71920-002030	2
5	PE BF MAN 4"*1 OUT*3" VIC F/48" TANK	71920-002020	2
6	PE STUB END 4" W/O FLANGE extended	71920-002305	1
7	METAL TRANSITION 10" ANSI FLANGE*VIC	71910-002015	2
8	PE CAP 4" VIC	71920-002405	1
9	PE CAP 8"VIC W/1 OUT 3/4"BSP+2 OUT 2"BSP	71920-002508	1
10	PE CAP 8" VIC W/1 OUT 3/4" BSP	71920-002509	3
11	METAL TEE CON 10*8*10 VIC L-460MM	71910-002302	2
12	METAL NIPPLE VIC/VIC 4"*460MM	71910-009010	1
13	DOROT BF valve 4"*3"*4" vic vic vic	71600-006595	6
14	4" THROTTLE VALVE FLANGED TYPE F/BF MAN	71920-000110	1
15	VICTAULIC COUPLING 3" ONE BOLT	71910-002501	6
16	VICTAULIC COUPLING 4" ONE BOLT	71910-002502	24
17	VICTAULIC COUPLING 8" TWO BOLT	71910-002504	12
18	VICTAULIC COUPLING 10" TWO BOLT	71910-002505	2
19	LOOSE FLANGE PP ANSI 110X4"	75090-012415	1
20	S75PL H 2" QRV NPT PP 3WNC R	71600-002338	1
21	Plastic Nipple 2" BSP	75090-012457	1
22	Control stand + controller + Aquative bracket		1
23	CONTROL KIT FOR MEDIA FILTER - BSP	37090-009600	1
24	L.P. Check point (part of control kit)		3
25	BARAK PLASTIC BASE 2 GD-010(NPT)	70561-001500	1
26	SUPPORT LEG 8"X1440 FOR NC	71920-003050	2
27	SUPPORT LEG 8"X410 FOR NC	71920-003040	6
28	SUPPORT LEG 4"X1180 FOR NC	71920-003010	2

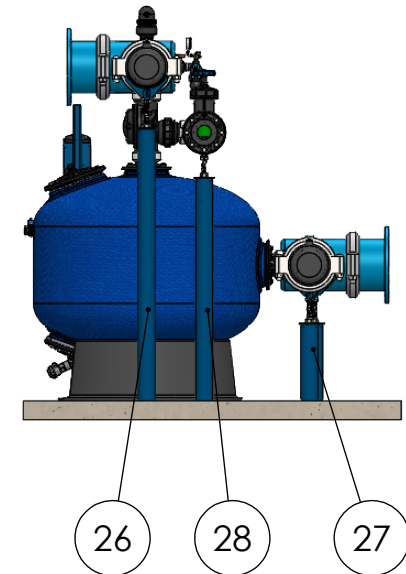
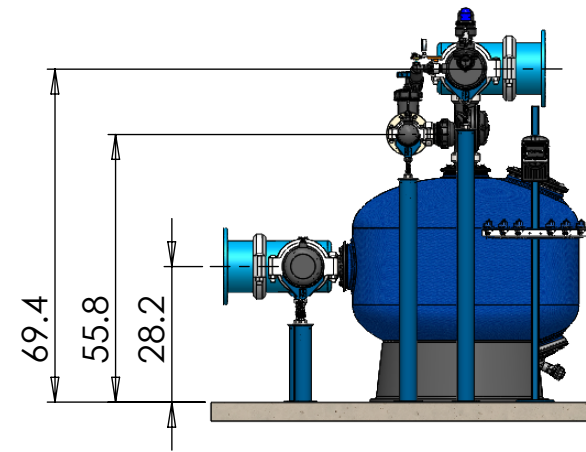

SAP DESCRIPTION:

NC 480610 C

SKU No.

Maximum Flow Rate: 2244 GPM

Recommended Flow Rate: 1848 GPM

Inlet Pressure: 115 PSI

Sheet Size:

A4

Scale:

1:40

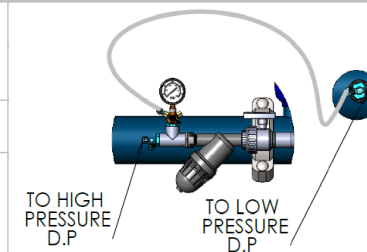

PROPRIETARY AND CONFIDENTIAL
THE INFORMATION CONTAINED IN THIS DRAWING IS THE SOLE PROPERTY OF NETAFIM. ANY REPRODUCTION IN PART OR AS A WHOLE WITHOUT THE WRITTEN PERMISSION OF NETAFIM IS PROHIBITED

Designed By: KEREM 28/04/2021

Drawn By: KEREM 28/04/2021

Checked By:

QA

Sheet: 3 Of: 3 Rev. -