

WASTEWATER DIVISION

# WASTEWATER REUSE AND DRIP DISPERSAL DESIGN GUIDE



# WASTEWATER REUSE AND DRIP DISPERSAL GUIDE

---

## TABLE OF CHARTS AND ILLUSTRATIONS

## Table of Contents

Introduction.....	3
Netafim Bioline Dripperline .....	4
Why Netafim Only Uses Pressure Compensating Dripperline .....	5
Basic Assumptions .....	7
Wastewater Flow Determination.....	8
Site Considerations.....	12
Soil Considerations.....	14
Sample Collection.....	14
Determining Soil Texture .....	15
Restrictive Layers.....	15
Native vs. Disturbed Soils.....	16
Soil Hydraulic Loading Rate.....	17
System Components.....	20
Zone Requirements.....	24
Piping Layout.....	24
Minimizing Linear Loading by Working with Topography .....	25
Protecting the Piping Network .....	25
Drainback Considerations.....	28
Dosing and Controls.....	29
Recommended Drip Dispersal Operation Controls .....	30
Sequence of Operation.....	30
How to Dose .....	31
Dose and Flush Volumes .....	32
Filters and Filter Cleaning.....	34
Field Flush .....	36
Root Intrusion.....	36
Installation.....	37
Operation and Maintenance .....	40
Typical Layouts .....	41
Freezing Climate Design and Other Considerations.....	46
Netafim Product Warranty .....	49

## Tables

### Table No.

1. Maximum Length of Bioline Laterals ...	5
2. Non-Pressure Compensating Dripper Flow Rate vs. Pressure.....	6
3. Bioline Dripper Flow Rate vs. Pressure .....	6
4. Average Daily Residential Wastewater Flows.....	8
5. Residential Water Use by Fixture or Appliance .....	9
6. Commercial Water Use by Fixture or Appliance .....	10
7. Institutional Water Use Typical Flow Rates.....	11
8. Recreational Water Use Typical Flow Rates.....	12
9. Slope Conversion .....	14
10. Sample Soil Loading Rates .....	18
11. Maximum Length of Bioline Laterals.....	27
12. Recommended Dosing Tank Size Based on Bedrooms.....	31
13. Holding Volumes in Gallons for Pipe.....	32
14. Warranty Information .....	50

# WASTEWATER REUSE AND DRIP DISPERSAL GUIDE

---

## Tables

Metric Conversion Factors .....	51
Friction Loss Charts	
Sch 40 PVC.....	52
Sch 80 PVC.....	53
CL 315 PVC .....	54
CL 200 PVC .....	55
CL 160 PVC .....	56
CL 125 PVC .....	57
PE Pipe.....	58
Sch 40 Standard Steel.....	59
Type K Copper.....	60
Round Tank Capacity .....	61
Rectangular Tank Capacity .....	61
Conversion Charts .....	62
Friction Loss Through Fittings .....	63
Thermal Expansion.....	63
Contents of a Pipe.....	63
Conversion Formulas and Factors.....	64
Pressure Loss Through Water Meters.....	65
Temperature Conversion .....	66
11. Less Desirable Slope Layout.....	25
12. More Desirable Slope Layout.....	25
13. Screen Filter with Debris Passing Through .....	34
14. Disc Filter Ring .....	35
15. The MB-40 Multi-Blade Vibratory Plow.....	38
16. MB-40 Minimizes Damage to Existing Landscape.....	38
17. MB-40 Does Not Disturb the Grade.....	38
18. MB-40 Can be Mounted on the Vermeer RTX-450.....	38
19. "Drip and Fill" Technique .....	39
20. Mechanized Equipment.....	39

## System Layouts

Opposing Manifold Layout.....	42
Single Trench Layout .....	43
Irregular Field Shape Layout.....	44
Multiple Zone Layout.....	45

## Illustrations

### Figure No.

1. The Bioline Dripper .....	4
2. The Precision of the Bioline Dripperline .....	5
3. Typical Treatment System & Drip Dispersal System Layout.....	7
4. Soil Texture Triangle.....	15
5. "Soup Bowl Effect" .....	16
6. Sample Hydraulic Loading Rates Based on Soil Texture Triangle .....	17
7. Typical Air/Vacuum Relief Valve Detail .....	21
8. Loop and Flexible Connections.....	22
9. Start Connection with Flex Pipe on Flat Field Layout.....	23
10. End Start Connection with Flex Pipe on Flat Field Layout.....	23

## INTRODUCTION

This guide covers the basics of design for Netafim Bioline® drip dispersal applications. While secondary treated effluent will normally be used, many of the same design concepts for septic tank effluent may apply.

Because onsite wastewater designs are subject to state and local regulations, any regulatory specification must be given precedence over the recommendations included here. If local regulations allow design parameters which are more liberal than those expressed in this guide, the designer should bear in mind that the conservative recommendations herein are based on actual design experience and analysis of both properly functioning and failed onsite systems. When it comes to design, Netafim takes a conservative approach.

**This guide is not meant to replace the services of a design professional. Netafim recommends that a licensed professional be consulted for proper onsite system design and operation.**

### Overview

Drip technology was originally developed for the agricultural industry to improve the efficient delivery of water to plants, especially in environments where water supply is limited. The technique involved delivering water that plants actually use directly into the root zone and relying on horizontal and vertical movement through the soil to disperse the water evenly. Netafim is the world leader in drip applications and its drippers, filters, valves and other products have become industry standards around the world.

Subsurface drip dispersal is the most efficient method of dispersing wastewater effluent into the soil and presents the designer with a superior solution for virtually every soil type.

The Netafim drip dispersal solution delivers effluent into the shallow subsurface and biologically-active root zone of plants, allowing plant uptake for nutrient removal, and slow effluent dispersal into the soil medium for further treatment.

The U.S. Environmental Protection Agency (EPA) has recognized that onsite treatment of domestic wastewater is a permanent rather than temporary solution for wastewater treatment when centralized collection systems are not feasible. Increasing public concern about issues related to the effective and reliable treatment and dispersal of onsite wastewater has created a climate for change beyond conventional septic tanks and drainfields. The onsite industry has responded with improved technology for wastewater treatment and regulations have become more explicit and scientifically based. These are key reasons why interest in drip dispersal in the onsite industry has increased so rapidly.

As demand increases for residential development in formerly rural areas and in less-than-optimal site conditions for older-style onsite wastewater dispersal, the importance of alternative technologies increases. Advanced onsite wastewater treatment combined with drip dispersal is the best strategy for effectively treating and dispersing the treated wastewater.

Subsurface drip dispersal has a number of benefits:

- Very even effluent distribution over large areas, including slopes
- Can be applied in almost any climate or soil conditions, as well as high wind areas, odd shaped areas, close to buildings and high water table environments
- Reduced localized loading rates
- Potential of animal and human contact is much lower than other dispersal techniques
- Installation does not require major disruption to the drain field area, taking advantage of natural or modified landscape plans
- Provides for extended contact time with soil
- Effluent can often be re-used for irrigation of lawns, shrubs, and trees - nitrate and phosphorus uptake by plants is a further benefit

# WASTEWATER REUSE AND DRIP DISPERSAL GUIDE

## NETAFIM BIOLINE® DRIPPERLINE

- Beneficial wastewater nutrients are available for plant uptake and evapotranspiration is maximized
- Special consideration potential for use in a "green building" applications - the onsite treatment of the wastewater ensures no infrastructure strain on municipal treatment and the beneficial reuse of the effluent could include irrigation.

This guide focuses on Netafim Bioline® dripperline<sup>1</sup> as the drip dispersal product. Bioline is a state-of-the-art drip dispersal tubing that is manufactured specifically for wastewater applications. While Netafim manufactures hundreds of types of dripperline, including non-pressure compensating dripperline, the features and proven performance of Bioline make any reliance on non-pressure compensating dripperlines unnecessary. Chief among the reasons that Netafim Bioline pressure compensating dripperline is the chosen standard include:

- Broadest pressure compensation range of any dripperline: 7 - 58 psi
- Broadest range of dripper flow rates to choose from: 0.4, 0.6 or 0.9 GPH
- Dripper spacings of 12", 18" or 24" (custom spacings available)
- Bioline's continuous self-flushing design ensures drippers purge debris any time they are operating, not just at the beginning or end of a cycle
- Built-in physical root barrier protects against root intrusion without the need for chemical protection
- Large internal flow paths inside the dripper mean Bioline only requires 120 mesh/130 micron filtration
- Pressure compensating dripper design ensures even application of effluent across a broad area
- Dripperline lateral lengths are the longest in the industry
- No special storage or handling requirements ensure that outdoor storage is acceptable

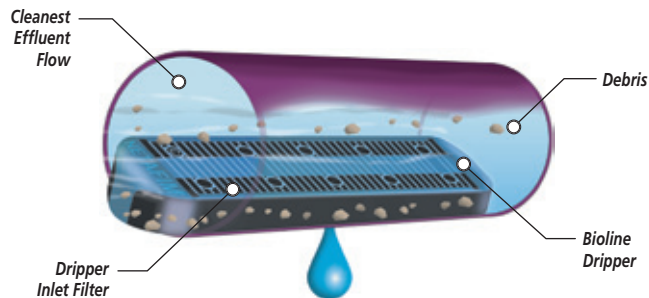

**Figure 1 - The Bioline Dripper.** Capturing the effluent from the center of the flow is critical to effective dripper operation. This shows how the dripper is positioned in the center of the flow and is less likely to suffer contamination like drippers that capture water from the wall of the pipe where it is dirtiest.

<sup>1</sup> At various times the following words will be used interchangeably:  
Bioline, drip tubing, dripline, dripperline, drip dispersal tubing.

Dripper Spacing		12"			18"			24"		
Dripper Flow Rate (GPH)		0.4	0.6	0.9	0.4	0.6	0.9	0.4	0.6	0.9
Inlet Pressure (psi)	15	292	233	175	410	322	247	510	405	308
	25	397	312	238	558	438	335	660	550	423
	35	460	365	260	656	514	394	760	649	497
	45	505	407	295	732	574	429	880	725	555

*Lateral lengths are calculated for operation while dosing, and allow for the pressure at the end of the dripperline to be 7 psi or greater. Their data does not take scouring velocity into account.*

**Table 1** - This chart shows the maximum lengths of laterals when using Netafim Bioline. The footage represents how far the dripperline can reach and how each dripper delivers equal flow under pressure compensating conditions. (These distances will decrease when designing for the appropriate flushing velocity and **should not be used for design purposes**. See page 29 for more information on lateral length data when using various flushing velocities).

## WHY NETAFIM ONLY USES PRESSURE COMPENSATING DRIPPERLINE

The fast answer about only using pressure compensating dripperline is:

- Predictable
- Forgiving
- Easy to design with
- Provides a continuous self-flushing feature
- Provides a very consistent flow over time



**Figure 2 – The Precision of Bioline Pressure Compensating Dripperline.** Across this broad area are thousands of feet of dripperline delivering equal discharge rates from each dripper. Non-pressure compensating dripperlines cannot equal this degree of precision.

# WASTEWATER REUSE AND DRIP DISPERSAL GUIDE

Pressure compensating (PC) dripperlines have been used in a variety of subsurface applications for decades. Whether the application is agriculture, where crop quality is largely dependant on each plant getting equal water, or landscape, where even watering yields well-balanced plantings and turf, pressure compensating dripperlines excel.

Beyond the design and maintenance ease that PC dripperline offers due to its precise and measurable rate flow, there is more. Bioline's ability to purge debris whenever it gets into the dripper is another reason Netafim does not use non-pressure compensating dripperlines for wastewater. Using a dripper that may only clean itself at the beginning or end of a dose can lead to drippers not operating properly. This does not happen with Bioline.

Certain soils have the ability to reduce or actually cut-off the flow of non-PC drippers. Especially in tight soils, pressure created in the soil by the water can increase to the point where a non-pressure compensating dripper can actually close and stop dripping. Though these pressures dissipate by gravity after dosing - eliminating it during dosing is the object. Even on flat terrain, using non-PC dripperline can significantly and negatively affect the quality of the dose.

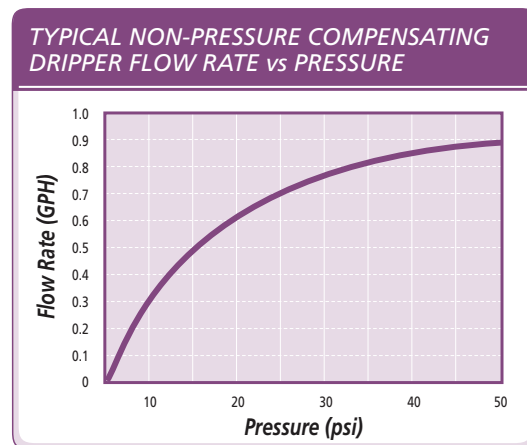

**Table 2** - The curved flow rate of a typical non-pressure compensating dripperline highlights why it is a poor choice for effluent dispersal. As the lateral length increases and/or the pressure decreases, the flow decreases as well. This makes designing a system difficult and reduces the effective management of effluent dispersal over the drip field.

**Table 3** - The flat flow rate line of Bioline represents the concept of pressure compensation and the resulting even discharge of water from each emitter along the full length of the dripperline lateral. This makes system design much easier and increases the effectiveness of effluent dispersal in the drip field, even if there are elevation differences.

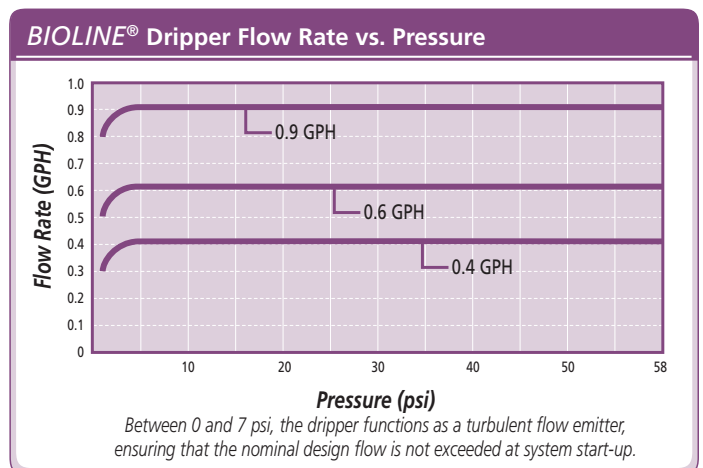

Between 0 and 7 psi, the dripper functions as a turbulent flow emitter, ensuring that the nominal design flow is not exceeded at system start-up.

# WASTEWATER REUSE AND DRIP DISPERSAL GUIDE

## BASIC ASSUMPTIONS

This guide assumes the following wastewater conditions:

- Secondary-treated, domestic strength effluent, though residential-strength septic tank effluent can be used with proper design, filtration and operation
- 30/30 (ppm) BOD/TSS
- Fats, oils, and grease (FOG) less than 20 ppm

This quality of effluent can be produced by any number of advanced onsite treatment technologies. While there are many successful drip dispersal systems on septic tank quality effluent wastewater, special care must be taken in the system design.

Effluent typically leaves the treatment system and enters into an adequately-designed storage (dosing) tank. These tanks allow for both a working level and reserve capacity above the high water level alarm. The drip dispersal system is designed to distribute the wastewater uniformly over the drip field throughout a 24-hour day or as local regulations dictate.

The control system regulates the flow and may also provide for filter and field flushing, zone selection and alarms whenever operational conditions are exceeded.

Since Bioline® requires pressure to function, pumps will normally be used to deliver the proper flow and pressure to the dripline laterals. System pressure is also required to operate filters (automatic or manual backflush), which remove suspended organic and inorganic particles.

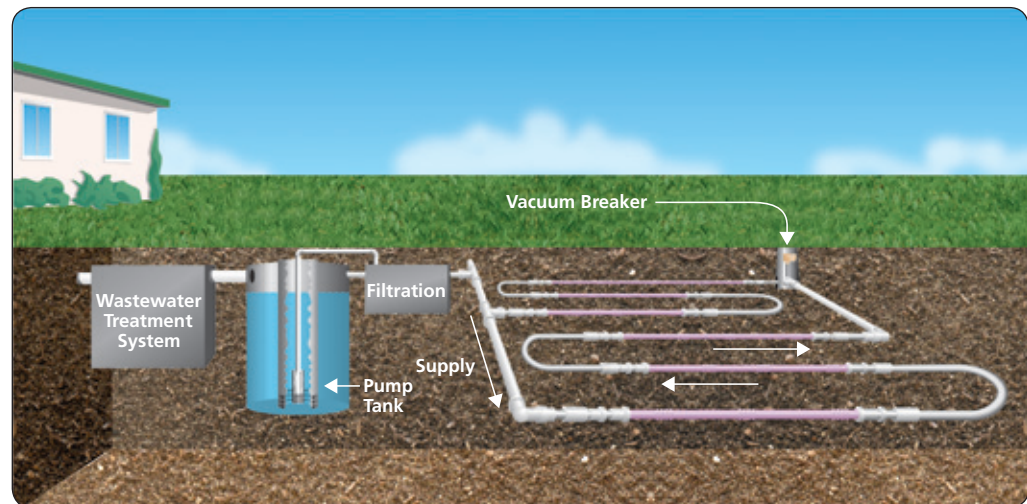

**Figure 3 - Typical Treatment System & Drip Dispersal System Layout.** Illustration provided by Texas Cooperative Extension.

Multiple zones of dripperline may be necessary or desired to keep pump size small and/or to meet local regulations, but pump capacity should allow for adequate flushing of the dripperline and piping network components during manual or automatic field flush cycles. Design considerations derived from these principles are detailed in this design guide.

Drip tubing is frequently installed at a depth of 6", but 8" to 12" depths may be recommended to minimize potential human or animal contact and to ensure proper effluent dispersal into the biologically-active soil layer. Cold climates may require even deeper burial, or additional cover based on local conditions. Installing dripperline below the soil's freeze depth is generally safe, but there are numerous installations at relatively shallow depths in cold climates with appropriate design and routine dosing. See the section titled "Freezing Climate Design and Other Considerations" on page 48.



# WASTEWATER REUSE AND DRIP DISPERSAL GUIDE

Most critical to a proper design is matching the soil's capacity to absorb water with the dripperline's application rates and the demand for dispersal of the design flow. In this regard, the designer must take into account:

- Water flow over, into, and through the soil
- Soil morphology (structure, texture)
- Storage of water in the soil column
- The loss of water to the air through evaporation
- Exchange to the air through plant transpiration

This design guide shows how accurate information about daily wastewater flow, proper soil analysis and thorough site evaluation will result in a successful and cost effective drip dispersal system.

**Note:** Netafim has developed an easy-to-use computer program to do many of the quantitative design analysis steps based on gallons available per day, soil loading rates, pump size, number of doses, etc. It is available on the Netafim Wastewater Division CD and on our website at [www.netafim-usa-wastewater.com](http://www.netafim-usa-wastewater.com). The following discussions provide the context for these calculations.

## WASTEWATER FLOW DETERMINATION

A drip dispersal system must accommodate the volume of wastewater effluent being generated. The following EPA charts<sup>2</sup> can be used for estimating the daily wastewater production rate for various activities. Actual water usage data or other methods of calculating wastewater usage rates must be used by the system designer if it is determined that, for whatever reason, quantities may exceed standard estimates.

**Note:** Estimates used for onsite wastewater treatment designs should always be approved by local regulatory authorities.

Residential occupancy from the 1998 U.S. Census Bureau indicated that the average occupancy per bedroom was 1.0 to 1.5 persons while the same census reported that the average household size was 2.7 people. Local census data can be used to improve the accuracy of design assumptions. The current onsite code practice is to assume that the maximum occupancy is 2 persons per bedroom. This provides an estimate that could be too conservative (meaning that wastewater flows are overstated) if additional safety factors are incorporated into the design.

**SUMMARY of Average Daily Residential Wastewater Flows<sup>a</sup>**

Study	Number of Residences	Study Duration (months)	Study Average (gal/person/day) <sup>b</sup>	Study Range (gal/person/day)
Brown & Caldwell (1984)	210	-	66.2 (250.6) <sup>b</sup>	57.3 - 73.0 (216.9 - 276.3) <sup>b</sup>
Anderson & Siegrist (1989)	90	3	70.8 (268.0)	65.9 - 76.6 (249.4 - 289.9)
Anderson et al (1993)	25	3	50.7 (191.9)	26.1 - 85.2 (98.9 - 322.5)
Mayer et al (1999)	1,188	1 <sup>c</sup>	69.3 (262.3)	57.1 - 83.5 (216.1 - 316.1)
Weighted Average	153	-	68.6 (259.7)	-

<sup>a</sup> Based on indoor water use monitoring and not wastewater flow monitoring.

<sup>b</sup> Liters/person/day in parentheses.

<sup>c</sup> Based on 2 weeks of continuous flow monitoring in each of two seasons at each home.

**Table 4 - Average Daily Residential Wastewater Flows**

<sup>2</sup> From EPA Publication EPA 625/R-00/008-Chapter 3.

# WASTEWATER REUSE AND DRIP DISPERSAL GUIDE

Based on the data in Table 4, estimated average daily wastewater flows of approximately 50 - 70 gallons per person per day (189 to 265 liters per person per day) would be typical for residential dwellings built before 1994.

<b>RESIDENTIAL WATER USE by Fixture or Appliance<sup>a, b</sup></b>				
<b>Fixture/Use</b>	<b>Gallons/Use (average range)</b>	<b>Uses/Person/Day (average range)</b>	<b>Gallons/Person/Day (average range)<sup>c</sup></b>	<b>Percent Total (average range)</b>
Toilet	3.5 (2.9 - 3.9)	5.05 (4.5 - 5.6)	18.5 (15.7 - 22.9)	26.7 (22.6 - 30.6)
Shower	17.2 <sup>d</sup> (14.9 - 18.6)	0.75 <sup>d</sup> (0.6 - 0.9)	11.6 (8.3 - 15.1)	16.8 (11.8 - 20.2)
Bath	See Shower	See Shower	1.2 (0.5 - 1.9)	1.7 (0.9 - 2.7)
Clothes Washer	40.5	0.37 (0.30 - 0.42)	15.0 (12.0 - 17.1)	21.7 (17.8 - 28.0)
Dishwasher	10.0 (9.3 - 10.6)	0.10 (0.06 - 0.13)	1.0 (0.6 - 1.4)	1.4 (0.9 - 2.2)
Faucets	1.4 <sup>e</sup>	8.1 <sup>f</sup> (6.7 - 9.4)	10.9 (8.7 - 12.3)	15.7 (12.4 - 18.5)
Leaks	n/a	n/a	9.5 (3.4 - 17.6)	13.7 (5.3 - 21.6)
Other Domestic	n/a	n/a	1.6 (0.0 - 6.0)	2.3 (0.0 - 8.5)
<b>Total</b>	n/a	n/a	<b>69.3 (57.1 - 83.5)</b>	<b>100</b>

<sup>a</sup> Results from AWWARF REUWS at 1,188 homes in 12 metropolitan areas. Homes surveyed were served by public water supplies, which operate at higher pressure than private water sources. Leakage rates might be lower for homes on private water supplies.

<sup>b</sup> Results are averages over range. Range is the lowest to highest average for 12 metropolitan areas.

<sup>c</sup> Gall/person/day might not equal gal/use multiplied by uses/person/day because of differences in the number of data points used to calculate means.

<sup>d</sup> Includes shower and bath.

<sup>e</sup> Gallons per minute.

<sup>f</sup> Minutes of use per person per day.

Source: Mayer et al., 1999

**Table 5 - Typical Flow Rates from Residential Sources**

# WASTEWATER REUSE AND DRIP DISPERSAL GUIDE

**COMMERCIAL WATER USE by Fixture or Appliance<sup>a, b</sup>**

Facility	Unit	Flow/Gallons/Unit/Day		Flow/Liters/Unit/Day	
		Range	Typical	Range	Typical
Airport	Passenger	2 - 4	3	8 - 15	11
Apartment House	Person	40 - 80	50	150 - 300	190
Automobile Service Station <sup>c</sup>	Vehicle Served	8 - 15	12	30 - 57	45
Automobile Service Station <sup>c</sup>	Employees	9 - 15	13	34 - 57	45
Bar	Customer	1 - 5	3	4 - 19	11
Bar	Employees	10 - 16	13	38 - 61	49
Boarding House	Person	25 - 60	40	95 - 230	150
Department Store	Toilet Room	400 - 600	500	1,500 - 2,300	1,900
Department Store	Employee	8 - 15	10	30 - 57	38
Hotel	Guest	40 - 60	50	150 - 230	190
Hotel	Employee	8 - 13	10	30 - 49	38
Industrial Building (sanitary waste only)	Employee	7 - 16	13	26 - 61	49
Laundry (self-service)	Machine	450 - 650	550	1,700 - 2,500	2,100
Laundry (self-service)	Wash	45 - 55	50	170 - 210	190
Office	Employee	7 - 16	13	26 - 61	49
Public Lavatory	User	3 - 6	5	11 - 23	19
Restaurant (with toilet)	Meal	2 - 4	3	8 - 15	11
Restaurant (conventional)	Customer	8 - 10	9	30 - 38	34
Restaurant (short order)	Customer	3 - 8	6	11 - 30	23
Restaurant (bar/cocktail lounge)	Customer	2 - 4	3	8 - 15	11
Shopping Center	Employee	7 - 13	10	26 - 49	38
Shopping Center	Parking Space	1 - 3	2	4 - 11	8
Theater	Seat	2 - 4	3	8 - 15	11

<sup>a</sup> Some systems serving more than 20 people might be regulated under US EPA's Class V Underground Injection Control (UIC) Program. See <http://www.epa.gov/safewater/uic.html> for more information.

<sup>b</sup> These data incorporate the effect of fixtures complying with the U.S. Energy Policy Act (EPACT) of 1994.

<sup>c</sup> Disposal of automotive wastes via subsurface wastewater infiltration systems is banned by Class V UIC regulations to protect ground water. See <http://www.epa.gov/safewater/uic.html> for more information.

Source: Crites and Tchobanoglous, 1998.

**Table 6 - Typical Flow Rates from Commercial Sources**

# WASTEWATER REUSE AND DRIP DISPERSAL GUIDE

<b>INSTITUTIONAL WATER USE Typical Flow Rates<sup>a</sup></b>					
<b>Facility</b>	<b>Unit</b>	<b>Flow/Gallons/Unit/Day</b>		<b>Flow/Liters/Unit/Day</b>	
		<i>Range</i>	<i>Typical</i>	<i>Range</i>	<i>Typical</i>
Assembly Hall	Seat	2 - 4	3	8 - 15	11
Hospital, Medical	Bed	125 - 240	165	470 - 910	630
Hospital, Medical	Employee	5 - 15	10	19 - 57	38
Hospital, Mental	Bed	75 - 140	100	280 - 530	380
Hospital, Mental	Employee	5 - 15	10	19 - 57	38
Prison	Inmate	80 - 150	120	300 - 570	450
Prison	Employee	5 - 15	10	19 - 57	38
Rest Home	Resident	50 - 120	90	190 - 450	340
Rest Home	Employee	5 - 15	10	19 - 57	38
School (day w/cafeteria, gym, showers)	Student	15 - 30	25	57 - 110	95
School (day w/cafeteria)	Student	15 - 30	15	38 - 76	57
School (day w/o cafeteria, gym, showers)	Student	10 - 20	11	19 - 64	42
School (boarding)	Student	50 - 100	75	190 - 380	280

<sup>a</sup> Systems serving more than 20 people might be regulated under US EPA's Class V UIC Program. See <http://www.epa.gov/safewater/uic.html> for more information.

Source: Crites and Tchobanoglous, 1998.

**Table 7 - Typical Flow Rates from Institutional Sources**

# WASTEWATER REUSE AND DRIP DISPERSAL GUIDE

RECREATIONAL WATER USE Typical Flow Rates <sup>a</sup>					
Facility	Unit	Flow/Gallons/Unit/Day		Flow/Liters/Unit/Day	
		Range	Typical	Range	Typical
Apartment, Resort	Person	50 - 70	60	190 - 280	230
Bowling Alley	Alley	150 - 250	200	270 - 950	780
Cabin, Resort	Person	8 - 50	40	80 - 190	150
Cafeteria	Customer	1 - 3	2	4 - 11	8
Cafeteria	Employee	8 - 12	10	30 - 45	38
Camp (pioneer type)	Person	15 - 30	25	57 - 110	95
Camp (children's w/toilet, bath)	Person	35 - 50	45	130 - 190	170
Camp (day w/meals)	Person	10 - 20	15	38 - 76	57
Camp (day w/o meals)	Person	10 - 15	13	38 - 57	49
Camp (luxury, private bath)	Person	75 - 100	90	280 - 380	340
Camp (trailer camp)	Trailer	75 - 150	125	280 - 570	470
Campground (developed)	Person	20 - 40	30	76 - 150	110
Cocktail Lounge	Customer	12 - 25	20	45 - 95	76
Coffee Shop	Customer	4 - 8	6	15 - 30	23
Coffee Shop	Employee	8 - 12	10	30 - 45	38
Country Club	Guest	60 - 130	100	230 - 490	380
Country Club	Onsite Employee	10 - 15	13	38 - 57	49
Dining Hall	Meal Served	4 - 10	7	15 - 38	28
Dormatory, Bunkhouse	Person	20 - 50	40	76 - 190	150
Fairground	Visitor	1 - 2	2	4 - 8	8
Hotel, Resort	Person	40 - 60	50	150 - 230	190
Picnic Park (flush toilets)	Visitor	5 - 10	8	19 - 38	30
Store, Resort	Customer	1 - 4	3	4 - 15	11
Store, Resort	Employee	8 - 12	10	30 - 45	38
Swimming Pool	Customer	5 - 12	10	19 - 45	38
Swimming Pool	Employee	8 - 12	10	30 - 45	38
Theater	Seat	2 - 4	3	8 - 15	11
Visitor Center	Visitor	4 - 8	5	15 - 30	19

<sup>a</sup>Some systems serving more than 20 people might be regulated under US EPA's Class V UIC Program.

Source: Crites and Tchobanoglous, 1998.

**Table 8 - Typical Flow Rates From Recreational Facilities**

## SITE CONSIDERATIONS

Before doing any detailed design specification, it is necessary to evaluate specific site features. This assessment should include the following:

**Site Boundaries:** Most state and local regulations will establish how close dripperlines may be placed to property lines, home foundations and other permanent property features.

**Special Features:** Community water distribution lines, property and utility easements, wells, treatment systems, water lines from wells, etc., require setbacks; 50 to 100 feet is typical. Surface waters, including ditches, ponds, lakes, streams and even intermittent water courses also require specific setbacks. Follow all local regulations.

# WASTEWATER REUSE AND DRIP DISPERSAL GUIDE

---

**Prior Land Use:** Research should be conducted to identify any prior activities on the proposed site that may have affected soil characteristics. These effects could include compaction, foreign soils, buried materials, etc.

**Future Land Use Restrictions:** The drip dispersal field can be installed under a permanent lawn, among trees or other landscape features, provided that proper set backs are followed. Any future permanent structures that will affect soil texture and water flow through the soil must be avoided over a drip dispersal field, including but not limited to the following: out-buildings, parking areas, swimming pools, tennis courts, home additions, decks, etc. The designer should consult with the property owner regarding anticipated improvements to the property and avoid these areas.

**Precipitation and Landscape Position:** If the site is in an area that experiences seasonal, intense, or even short duration precipitation events consider regrading the area to encourage direct runoff.

**Slope:** Slope or slope gradient is the inclination of the surface of the soil from horizontal and is expressed as a percentage of the distance between those points.

## **Examples:**

1. If the difference in elevation is 1 foot over a horizontal distance of 100 feet, slope gradient is 1%.
2. A slope that drops 10 vertical feet in 100 horizontal feet is a 10% slope (vertical drop/horizontal distance times 100).
3. A slope of 45° is a slope of 100 percent, because the difference in elevation between two points 100 meters apart horizontally is 100 meters on a 45° slope.

**Note:** The higher the percent, the steeper the slope!

The elevation of a slope is important because it determines the rate at which water (and effluent) flows downhill. Water flows slowly over a gentle slope and rapidly over a steep one. The steepness of a slope has been evaluated by the United States Department of Agriculture's Soil Conservation Service as follows:

- Nearly level (0 - 2%). Has no limitation on its uses. Any limitations are the result of other factors, such as drainage.
- Gently Sloping (3% - 6%). Desirable for almost any type of development; may have erosion problems; limitations are due mostly to factors other than slope.
- Moderately Sloping (6% - 12%). May have severe erosion problems and has a strong appeal for single-family development.
- Strongly Sloping (12% - 18%). Has severe limitations for all types of construction. Residential development is sometimes considered because of the scenic views associated with such terrain, or when other sites are unavailable.
- Steep Slopes (18% and over). Undesirable for most development.

The Slope Conversion chart shows equivalences between percentage of gradient and angle of slope in degrees.

Drip dispersal encourages lateral (horizontal), not just vertical movement throughout the soil. This makes it an excellent choice for both level surfaces and slopes. This is especially true with the use of pressure compensating emitters and proper zoning. Additional considerations about slopes include whether:

- There is a natural or artificial barrier down-slope from the proposed site that could provide opportunities for water to surface (such as hillside cuts or walls)
- The drip tubing can be laid out along the contour of the slope
- System geometry can be used that minimizes linear loading rate
- The design can incorporate air release valves, check valves, zones and other means to equalize flow and to prevent drainback (See the design and layout discussions that follow.)

**SLOPE Conversion**

Percent	Angle	Angle	Percent
0	0° 00'	0°	0
5	2° 52'	2°	3.5
10	5° 43'	4°	7.0
15	8° 32'	6°	10.5
20	11° 19'	8°	14.0
25	14° 02'	10°	17.6
30	16° 42'	12°	21.2
35	19° 17'	15°	26.8
40	21° 48'	20°	36.4
50	26° 34'	25°	46.6
60	30° 58'	30°	57.7
70	34° 59'	35°	70.0
80	38° 39'	40°	83.9
90	41° 59'	45°	100.0
100	45° 00'	50°	119.2

**Table 9 - Slope Conversion Chart**

With consideration of the above issues, and any similar issues that the designer believes may affect soil absorption rates, the designer is now ready to evaluate the specific soil characteristics.

## SOIL CONSIDERATIONS

After the drip dispersal area has been identified, the designer must undertake a thorough study of the specific soil characteristics of the proposed field. Particular attention must be given to:

- Texture
- Site uniformity
- Compaction
- Native vs. disturbed soils
- Soil depth to restrictions or water table
- Clay mineralogy

## SAMPLE COLLECTION

An accurate representation of the overall site condition requires that a determination of the underlying soil characteristics be done. A minimum of two samples per proposed zone is strongly recommended. The sample should be a three-dimensional soil core sample which, if possible, extends into the soil a minimum of two feet deeper than the proposed location for the drip tubing. The analysis of the soil core must establish the morphology, structure and texture, as well as the determination of the presence of ground water, seasonal high water table, restrictive layers, etc. USDA/NRCS Soils Maps or other locally available geological maps should be consulted to determine consistency between observed and referenced conditions. Any inconsistencies should result in further investigations of site particulars and history.

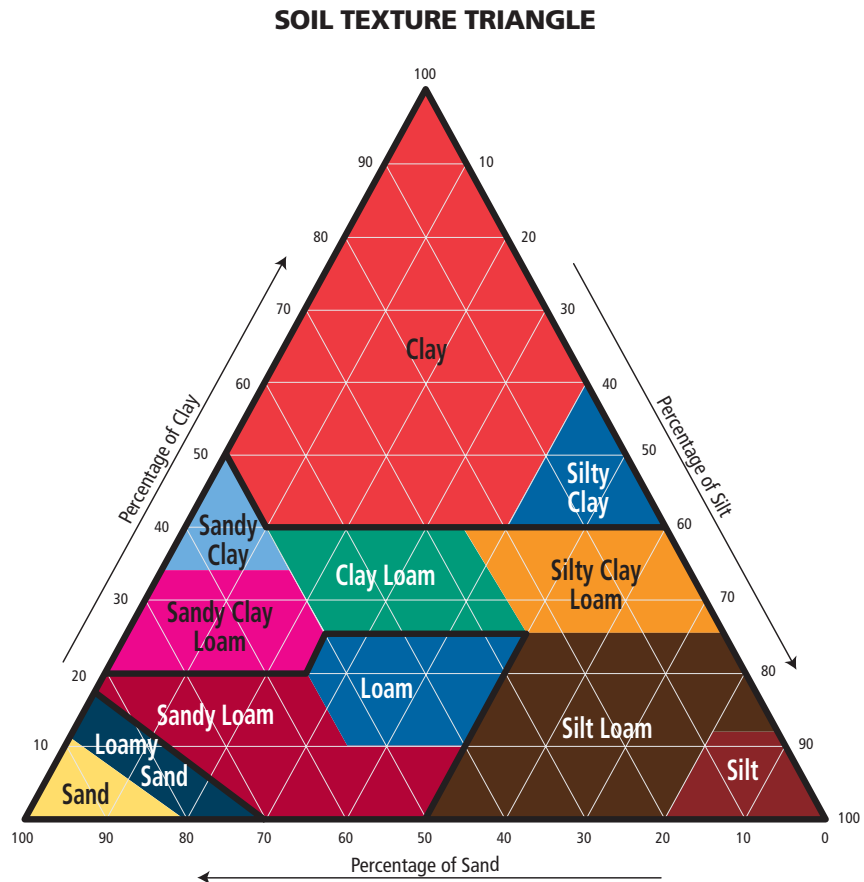

Figure 4 - Soil Texture Triangle

## DETERMINING SOIL TEXTURE

Accurate analysis of the samples is critical in determining the absorptive capacity of the soil. If samples from the various locations of the proposed site are different, the design will typically be based on the most restrictive sample.

The system designer should always consult with a registered soil scientist, site evaluator or soils structure laboratory for assistance in determining an accurate soil texture classification.

The USDA Soil Texture Triangle chart serves as an outline to determine soil composition and texture, leading to suggested loading rates.

## RESTRICTIVE LAYERS

Many soil environments are surrounded by other soils with less desirable characteristics. It should be recognized that water movement through multiple soil types will be determined by the characteristics of the most restrictive types. Therefore, whenever these restrictive types are encountered in a proposed drip field, they should provide the operative design criteria. In particular, soil absorptive capacities should be based on those of restrictive layers rather than those of the more absorptive soils. If restrictive layers are present within two feet below the dripperline, then the designer should use the reduced loading rates of the restrictive layer. The greater the soil depth to a restrictive layer, the better.

Considering the area two to four feet below the tubing: if there is a soil classification change of one class or more, or if a restrictive boundary layer exists (rock, tight clays, etc.), then the dispersal area should be increased. Consult local regulations for how much the area should increase.



## NATIVE VS. DISTURBED SOILS

Native, non-disturbed soils are always the most desirable medium for drip application. However, if the soils are very poor, or the site conditions (e.g., available space) are limited, and if regulations permit, the designer may consider the introduction of fill material.

If the proposed drip field employs soil fill material, artificially compacted soils, or mixed soils, special considerations apply. Although the fill material may have a greater soil absorptive capacity, the design should not rely on the better soil classification if the underlying poor soil is still present and utilized in the drip system design. Mixing or tilling of the soils may increase the soil absorptive capacity. However, adding Class II soils to a Class IV site does NOT yield a Class III absorptive capacity. A proper analysis by a soils laboratory with an engineering rather than agricultural focus is necessary to determine the new soil characteristics. In addition, at any time that a drip field is constructed with added soil, the overall field should be larger than otherwise called for in the design, and the loading rate should be determined by the restrictive layers and other site conditions rather than by the constructed soils.

The “soup bowl” graphic below demonstrates the problem. If the bowl area is scooped out and replaced with more absorptive soils, system failures may still occur because the water will be trapped in the bowl. Conversely, if the situation is reversed, such as with a “mound” configuration, water will tend to escape at the interface between the imported and native soils.

With the noted constraints used to define the overall characteristics of the proposed drip dispersal site, the designer is now prepared to establish a loading rate for the soil.

### SOUP BOWL EFFECT OF SOIL ADDITION

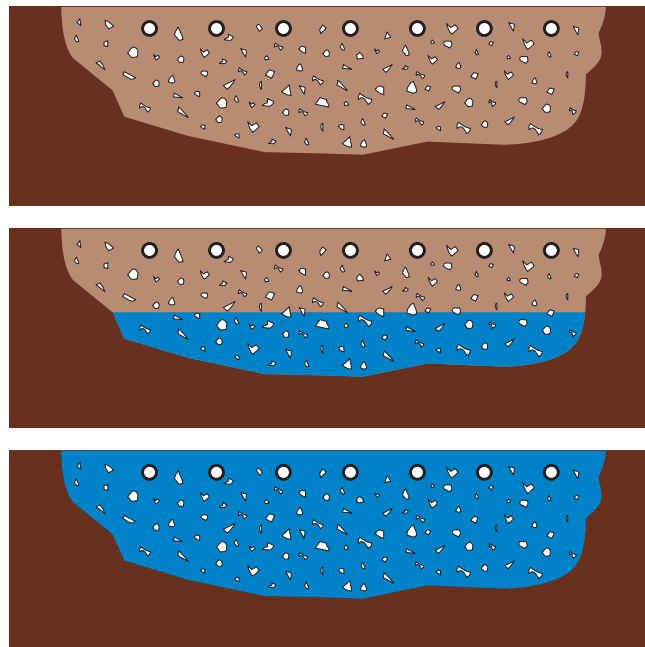

*Adding good quality soil fill does not relieve poor qualities of the soil that surround it.*

*The effluent will saturate the fill since the restrictive layer around the good soil fill does not permit proper draining.*

*Surfacing of effluent will eventually occur.*

Figure 5 - “Soup Bowl Effect” (circles indicate dripperline laterals).

## SOIL HYDRAULIC LOADING RATE

The success of a drip dispersal system is largely due to how accurately the dose rate is matched to the ability of the wastewater to be hydraulically conveyed through the soil. The soil loading rate is the estimated volume of water (expressed in gallons) that a square foot of the most restrictive soil in a horizon will accept and properly treat in one day, without creating ponding conditions. It is a rate that is determined by analyzing the soil texture and structure of the most restrictive soil horizon<sup>3</sup>. For a more thorough understanding of the importance of water movement through the soil "Darcy's Law" summarizes the properties that groundwater exhibit when moving through a porous medium.

While some perc rate data using the mpi method (minutes per inch) has been created, it is not generally considered an accurate way to determine hydraulic loading rate since the claims are not backed by scientific soil science studies. As such, Netafim relies on soil hydraulic loading rate information as is presented here. Netafim further encourages the use of a soil scientist or other trained soils professional.

While maximum loading rates are determined by structure, slope, depth to restriction and soil texture, we will consider soil texture and structure classification as the determinant for soil hydraulic loading rate. A more thorough analysis, including depth and slope should be always incorporated into design considerations.

Different soil textures have different porosities and therefore enable different quantities of water to pass through them. In drip dispersal, the goal is shallow dispersal, not deep percolation or surfacing. Therefore, soil textures both at the surface and below the surface are important to enable wastewater to flow both horizontally and vertically, allowing the loading of the soil at an even rate in the biologically active zone near the surface. This improves treatment through better oxygenation and enhances plant uptake through evapotranspiration. Two sample loading rate charts follow.

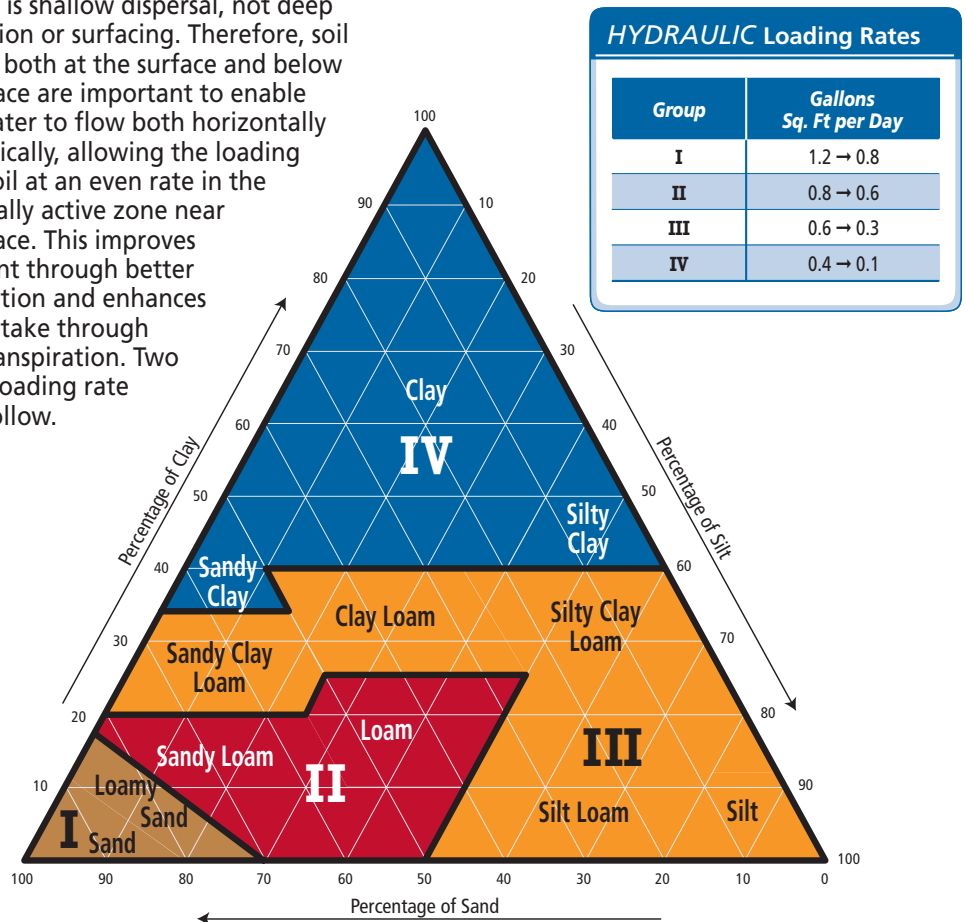

Figure 6 - Sample Hydraulic Loading Rates Based on Soil Texture Triangle

<sup>3</sup> A sample Soil Loading Rate chart has also been included as part of the Netafim computer design program.

# WASTEWATER REUSE AND DRIP DISPERSAL GUIDE

SAMPLE SOIL Loading Rates			
Soil Texture	Soil Structure	Max. Hydraulic Loading Rate <i>(gallons per sq. ft., per day)</i>	Area Required <i>(sq. ft., per 100 GPD)</i>
Coarse Sand	n/a	1.5	67
Loamy Sand	n/a	1.5	67
Sand	n/a	0.8	125
Loamy Sand	Moderate to Strong	0.8	125
Loamy Sand	Massive or Weak	0.5	200
Fine Sand	Moderate to Strong	0.8	125
Fine Sand	Massive or Weak	0.5	200
Loamy Fine Sand	Moderate to Strong	0.8	125
Loamy Fine Sand	Massive or Weak	0.5	200
Very Fine Sand	Moderate to Strong	0.8	125
Very Fine Sand	Massive or Weak	0.5	200
Loamy Very Fine Sand	Moderate to Strong	0.8	125
Loamy Very Fine Sand	Massive or Weak	0.5	200
Sandy Loam	Moderate to Strong	0.5	200
Sandy Loam	Massive or Weak	0.3	333
Loam	Moderate to Strong	0.5	200
Loam	Weak	0.5	200
Loam	Weak Platy	0.5	200
Loam	Massive	0.2	500
Silt Loamy	Moderate to Strong	0.5	200
Silt Loamy	Weak	0.5	200
Silt Loamy	Weak Platy	0.5	200
Silt Loamy	Massive	0.2	500
Sandy Clay Loam	Moderate to Strong	0.3	333
Sandy Clay Loam	Weak	0.2	500
Sandy Clay Loam	Weak Platy	0.2	500
Sandy Clay Loam	Massive	0.15	667
Clay Loam	Moderate to Strong	0.3	333
Clay Loam	Weak	0.2	500
Clay Loam	Weak Platy	0.2	500
Clay Loam	Massive	0.15	667
Silty Clay Loam	Moderate to Strong	0.3	333
Silty Clay Loam	Weak	0.2	500
Silty Clay Loam	Weak Platy	0.2	500
Silty Clay Loam	Massive	0.15	667
Sandy Clay	Moderate to Strong	0.1	1,000
Sandy Clay	Weak to Massive	0.05	2,000
Clay	Moderate to Strong	0.1	1,000
Clay	Weak to Massive	0.05	2,000
Silty Clay	Moderate to Strong	0.1	1,000
Silty Clay	Weak to Massive	0.05	2,000

*Example only, please refer to local regulations.*

**Table 10 - Sample Soil Loading Rate Chart**

Some states have regulations specifying loading rates that may vary from Table 10 or Figure 6. The designer must follow regulations and should whenever possible, adopt a conservative design approach.

**CALCULATING DRIP DISPERSAL AREA:  
APPLICATION AREA = DAILY FLOW / LOADING RATE**

Example: If the system will have 450 gallons per day and the soil is loam texture with weak, platy structure (0.5 gallons per square foot per day):  $450 / 0.5 = 900$  Square Feet of Area will be required.

Designers should take into account that proposed loading rates are for optimal soil conditions and any site-specific special circumstances including, but not limited to, the following need to be considered in the design:

- Specific features
- Precipitation
- Slopes
- Prior and adjacent land uses
- Impervious boundaries
- Depth to limitation
- Vegetation

**NOTE:** We mention again that Netafim believes that a conservative design approach is the best approach. A Netafim wastewater drip dispersal system has the ability to provide outstanding performance for many years. Taking time now to attend to the details will reward you with the performance you want and a very low total cost of ownership.

# WASTEWATER REUSE AND DRIP DISPERSAL GUIDE

## SYSTEM COMPONENTS

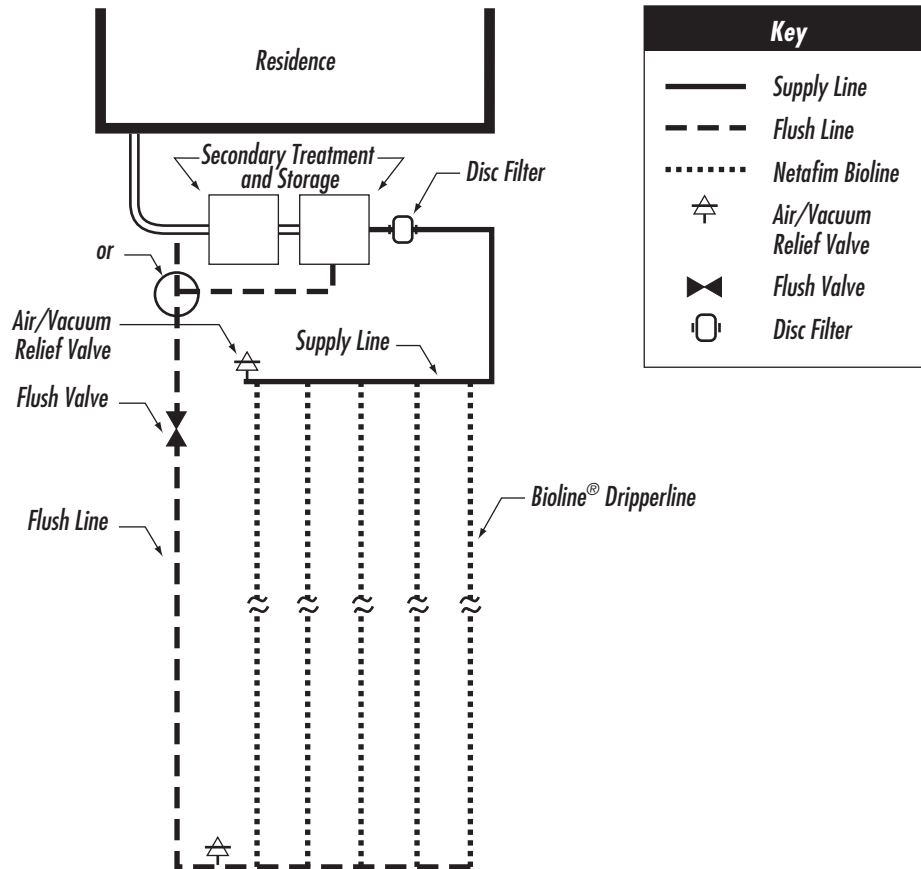

**Dripperline:** Bioline® is low volume dripperline with integral and evenly spaced pressure compensated emitters. Bioline is specifically manufactured for use with wastewater effluent and is the heart of the system. See the "Performance Specifications" section for details and performance specifications.

**Pumps:** Systems can be designed to use any type of commercially available high head pump. While many residential and commercial systems may use a small pump that produces 12 to 20 GPM, larger systems will need to be sized accordingly.

**Dosing Tank:** A storage tank is required to provide the operating capacity for the pump, to provide flow equalization, and to allow for peak and emergency storage. The operating capacity should allow for a minimum of 24 hours of the average daily flow to provide even distribution to the drip field throughout the day. See "How to Dose" section for more information on dose tank sizing. **Note:** Follow local regulations to determine storage requirement.

**Filtration:** Every drip system must include a filter to prevent introduction of sediments and suspended organic and inorganic materials into the dripperline. A 130 micron filter (120 mesh) is recommended for all Netafim Bioline dripperlines.

**Zone Valves:** When multiple zones are used, automatic solenoid valves are customarily used to turn zones on and off. Many automatic valves designed for standard irrigation may not withstand the more rigorous demands of wastewater effluent. Be certain that the valves you select are appropriate for the application.

# WASTEWATER REUSE AND DRIP DISPERSAL GUIDE

**Air/Vacuum Relief Valves:** Air in a drip dispersal system is both good and bad. Air/Vacuum Relief Valves perform a necessary function when a zone shuts down by allowing air to replace the effluent as it drains out of the dripperline. However, air can hinder proper system performance on zone turn on by delaying when the drippers farthest from the beginning of the zone system begin operating.

On zone turn on, Air/Vacuum Relief Valves quickly expel air in the dripperlines, allowing the dripperline to fill more quickly and helping to produce a more uniform dose, especially when short dosing intervals are used.

Designs should include a minimum of two Air/Vacuum Relief Valves per zone. They should be located at the highest point(s) of both the supply and flush manifolds and are typically placed in a valve box lined with gravel for protection. It is important that they always have access to free air.

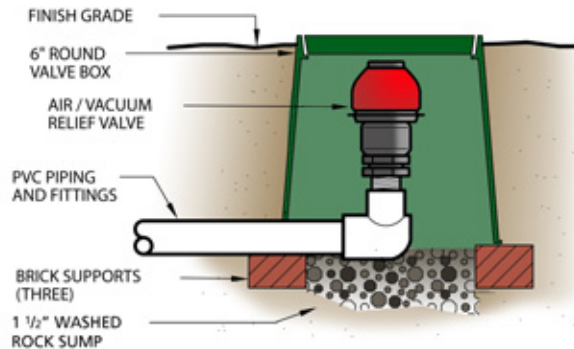

*Figure 7 - Typical Air/Vacuum Relief Valve Detail*

**Pressure Regulators and Pressure Regulation:** “PRV’s” ensure that a “not-to-exceed” pressure downstream of their location is achieved. They are helpful when supply pressures vary and could / do exceed the rating of the fittings or tubing. They can also mitigate issues with non-PC dripperline, especially on slopes.

Pressure Regulators should be considered when severe slopes are encountered or when pressures higher than 50 psi are present. Pressure regulators are typically located at the manifold of each zone where varying topographies exist.

When using Netafim Bioline® dripperline and appropriately sized pumps, it is not normally necessary to regulate pressure. Normal field operating pressure should be within a recommended range of 25 to 45 psi. Netafim Bioline is designed to provide uniform drip flow rates with pressures of 7 to 58 psi at the emitter, but PRV’s should be considered if operating pressures could or will exceed 50 psi.

**Check Valves:** Check valves are designed to only allow flow in one direction. They are frequently found on slope layouts and are also used in multiple zone layouts where a common flush line is being used. This ensures that only the currently activated zone for dosing is receiving effluent. See page 45 for designing check valves in multiple zone layouts.

## WASTEWATER REUSE AND DRIP DISPERSAL GUIDE

---

When supply and return headers are installed going up (with) the slope, check valves help to prevent the zone's effluent from draining down to the lowest point or flowing back to the dose tank.

**Loops and Flexible Connections:** Bioline® dripperline or Bioline blank tubing can easily be made to turn 180 degrees in applications where the rows are 24" apart. However, for maximum long-term protection against kinking, especially in freeze-thaw conditions, it is common practice to install flex PVC pipe whenever a turn of 45 degrees or more is made. These flex connections are used to prevent the possibility of kinking the dripperline which could reduce or shut off the flow. Flexible connections are also used to connect Bioline to the supply and return manifolds. The primary purpose in this case is to ensure that any sharp objects or other debris that may be in the trenches of the supply and flush headers do not cut the dripperline. It also helps to protect against the shrinking, swelling, movement and settling of the soils.

The flex connection also prevents dripperline flow from entering the trench of the supply and flush manifolds. Because these trenches may run up and down slope, they can become drains, with the potential for effluent surfacing at the downstream end. As such, it is highly recommended that the dripperline not drip into the trench.

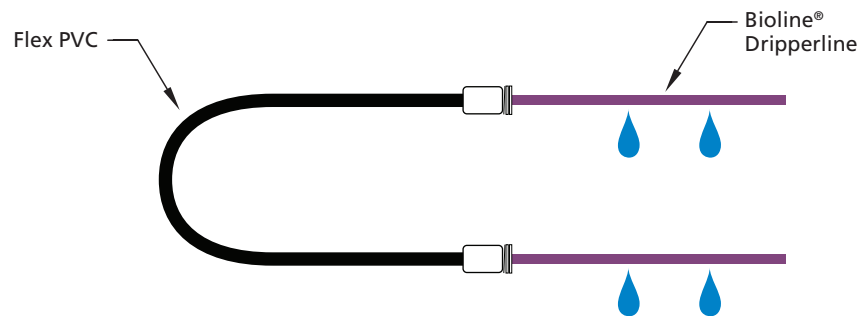

*Figure 8 - Loop and Flexible Connections*

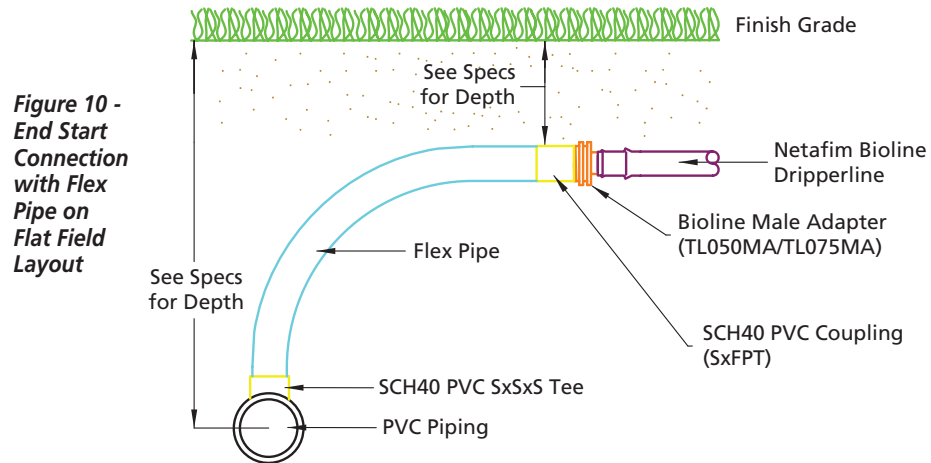
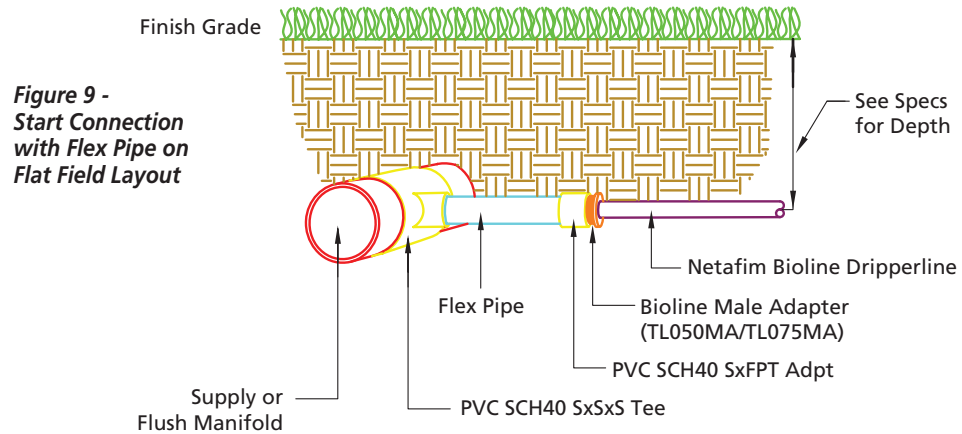

**Supply Line:** While most systems use Schedule 40 PVC, the correct pipe should be used to match the conditions. Check local code.

**Supply Manifold:** Schedule 40 PVC (or as appropriate for conditions) piping is the standard of design where the effluent is distributed to the Bioline® via flex connections. Drops in system pressure should be minimized to ensure that a sufficient flushing velocity is maintained. Connections to the supply and flush manifolds (number of laterals) should be minimized for system efficiency.

**Dripperlines:** Effluent flows through Bioline and into the soil through its emitters (drippers). The emitters each have a specific flow rate of 0.4, 0.6, or 0.9 gallons per hour (GPH). The flow rates are designed to prevent overloading of the soil and allow the designer to match the capacity of the soil to the flow rate of the dripper. In general, the lower the dripper flow rate, the slower the infiltration rate of the soil.

**Flush Manifold:** The characteristics of the flush manifold are the same as the supply manifold both in terms of material, size and number of connections.

**Flush Line:** In an effort to reduce the use of different size pipes and fittings, the flush line is typically the same size and type as the flush manifold. However, it can be sized as a function of the actual flow (which is less than the supply pipe delivers due to the dosing that occurs in the dripline) and the distance it has to travel back to where it terminates. It normally terminates at the front end of the treatment system in systems when intermittent dripline flushing is being done or into the dosing tank through the flow inducer when used with



continuous flush headworks. If it flows into the dosing tank, periodic checking and cleaning of the tank is recommended, along with feeding the flush water into the tank through a flow inducer to eliminate any agitation of the dose tank effluent. The destination of the flush line and flush water may be dictated by local regulations.

The flush line should have an easy-to-access manual or automatic valve to activate the field flush cycle and/or to perform service.

**System Controller:** The controller manages the timed dosing schedule, field flush and filter flush cycles (if part of the system), as well as the dosing pump(s). The complexity of the controller is matched to the application, user, and the level of trained maintenance used. A more thorough discussion of the system controls is found in the "Sequence of Operation" section.

**Water Meter:** Accurately measuring effluent flow into the dispersal system is an excellent way to ensure the system is operating properly and is valuable in troubleshooting. Placed downstream of the filter, a simple propeller-type meter capable of handling effluent is sufficient. More sophisticated units with feedback loops can be added.

## ZONE REQUIREMENTS

The number of zones can be determined in a variety of ways and for a number of reasons. In some states, there are a maximum number of drippers allowed per zone. Or, it may be a function of the total system flow divided by the pump's capacity. It may also be a function of balancing out dripperline zones on slopes or over other uneven surfaces. Using multiple zones also reduces the time required to fill the dripline zone so that a balanced dose can be achieved as well as increasing the rest time between doses. Check local regulations.

**Maximum Zone Size (Number of Zones):** If total system flow exceeds the pump's capacity or if there are significant topographic or other site constraints, multiple zones should be considered. This will help ensure that there is sufficient system capacity for field flushing, as well as reducing the fill time of the zone. Mechanical or solenoid valves are the typical choice for splitting the system into two or more zones.

When using multiple zones, try to balance the zones to equalize flows for both dosing and flushing.

In order to ensure that the zone size does not produce an excessive pressure drop which will not provide for a proper flushing velocity, a Bioline® calculator has been developed. It is available on our Wastewater Division CD or as a free download. To order, visit the literature download section of our wastewater website at [www.netafimusa.com](http://www.netafimusa.com).

## PIPING LAYOUT

There are many ways to lay out drip dispersal fields. It is common design practice to arrange the tubing so that dripperline lateral lengths are roughly equal and approximately 300 feet in length (refer to page 27 for actual lateral lengths for the various Bioline flow rates and dripper intervals.) Lengths greater than these may:

- Require the pump(s) to create more head and flow
- May not allow the dripperline to perform optimally
- May require too large of a drip field area to precisely manage.

It is standard practice to space rows of Bioline 24" apart, however, if the soil is capable of handling higher infiltration rates, there is no reason that the rows cannot be spaced more closely<sup>5</sup>. Check local codes.

It is also standard practice to use 1¼" PVC pipe for distribution lines, supply and flush manifolds, and the flush line. On most systems up to about 1,500 gallons per day, this size pipe optimizes flow and minimizes friction loss.

---

<sup>5</sup> If spacing rows closer together is acceptable under local rules and if the soils permit it, the drip dispersal field may become an important part of a beneficial reuse subsurface irrigation system. Netafim has information on its Landscape & Turf Division web page regarding dripper flow rates, dripper interval and row spacing for subsurface irrigation of plants and turfgrass. Visit <http://www.netafim-usa-landscape.com> for more information.

## MINIMIZING LINEAR LOADING BY WORKING WITH TOPOGRAPHY



**Figure 11 - Less Desirable Slope Layout**

*Laterals do not take advantage of the broad area of available soil to work with. This bunching of laterals increases the number of rows needed and increases the chance of saturation at the base of the slope.*



**Figure 12 - More Desirable Slope Layout**

*Laterals move across (perpendicular) to the slope. Extending the laterals across the slope reduces the number of dripperline rows and increases the amount of workable soil.*

## PROTECTING THE PIPING NETWORK

### Flushing & Scouring of Dripperlines:

The subject of flushing, “forward field flushing” or scouring of dripperlines is an important one, in part because everyone seems to have a different approach to it.

It is generally agreed that the inside of the piping network can develop a build-up of microbial slimes that could degrade system performance. There is also the chance for inflow into the piping network from rainfall or normal on-off cycling of the system. But there are other issues as well.

The chance of the treatment system being completely sealed needs to be addressed. “The preponderance of septic tanks sold in the U.S. are structurally unsound and almost never watertight.”<sup>6</sup> As such, “Because leaky tanks can exfiltrate, ... floatable solids, fats, soaps, oils and greases can be dosed or washed through the outlet assembly,”<sup>7</sup> looking only at the type of wastewater being used only looks at part of the problem.

Protecting the system means that we are not just considering the dripperline component because we have protected the drippers with anti-microbial protection. We need to look at

<sup>6</sup> “Design and Performance of Septic Tanks”, T.R. Bounds, P. E.

<sup>7</sup> “Design and Performance of Septic Tanks”, T.R. Bounds, P. E.

the entire system and consider the other components that will benefit from forward flushing:

- All other piping beside the dripperline
- Valves
- Fittings and other velocity-hindering junctions

### **Protecting the Bioline® Dripperline**

In order to lessen any adverse effects of slime build-up, Netafim incorporates an antimicrobial additive into the dripper. This additive acts to reduce the build-up of microbial slimes and has proven itself to be very effective. In addition to the antimicrobial additive, designing the drip dispersal system to flush additional effluent at an increased velocity is the norm. The speed and frequency of this action may be a topic of debate, whether it should be done is not.

### **Protecting the Rest of the System**

The easiest and most common method for keeping the piping network and its allied components operating in peak condition is to design the system so that a flushing action can take place. This flushing action focuses on opening the network up so that additional flow can move through the network at an increased velocity, creating turbulence and releasing any build-up that may have occurred.

### **How Fast You Should Flush**

Many people look to science to try to get that answer. In terms of the quality of effluent, there is data to suggest that secondary effluent may only need a 0.5 - 1.0 fps velocity while raw wastewater with grit and other debris should have anywhere from 2.5 - 3.5 fps, and effluent following primary settling may be in the 1.5 - 2.0 fps range. While the conservative nature of Netafim leans toward a higher flushing velocity, the ultimate decision rests with local regulations and the engineer or designer.

### **Designing for a 2 fps Flush Velocity**

Designing for a 2 fps flush velocity often does not add any additional cost to a system. If it does, it might mean the minimal investment in an additional zone. As we have all seen in life, the adage that "an ounce of prevention is worth a pound of cure" usually wins out. The result of a well designed and maintained system is years of trouble-free operation. The cost of cutting corners can ultimately mean more money spent. When all of the costs, from installation, to the cost of the years of service performed are analyzed, what may have seemed more expensive in the beginning is really less expensive over time. That is the principle behind *Total Cost of Ownership* and it is why Netafim encourages conservative design approaches and active professional maintenance of an onsite system.

### **Netafim's Position on Flush Velocity**

Netafim has historically recommended using a 2 fps flushing velocity. This rate correlates to a Reynolds Number of 9000 which is well into the turbulent flow category (turbulent flow with Bioline begins with 0.9 fps). That said, there is no "correct" number since site and system conditions vary with every system. Among the considerations to be studied are whether the flushing is continuous or intermittent and the quality of the effluent.

Because of the varying nature of systems and the decision on flushing based on regulation or designer belief, Netafim provides Bioline lateral length design information for the following velocities: 3.0, 2.5, 2.0, 1.5, 1.0 and 0.5 fps.

### **Flushing Frequency**

The frequency of forward flushing is also open to debate, but a couple of factors help make the decision easier. Whether it is scheduled to be done several times a year, every 25 cycles, every 15 days, or on a continuous basis is not the issue. Doing it and doing it correctly is the issue.

# WASTEWATER REUSE AND DRIP DISPERSAL GUIDE

**BIOLINE DOSING CHART Maximum Length (feet) of a Single Lateral (0.5 & 1.0 fps)**

Dripper Spacing		12"			18"			24"		
Dripper Flow Rate (GPH)		0.4	0.6	0.9	0.4	0.6	0.9	0.4	0.6	0.9
Flushing Velocity (fps)		0.5 / 1.0	0.5 / 1.0	0.5 / 1.0	0.5 / 1.0	0.5 / 1.0	0.5 / 1.0	0.5 / 1.0	0.5 / 1.0	0.5 / 1.0
Inlet Pressure (psi)	15	301 / 248	242 / 205	188 / 163	422 / 344	341 / 285	265 / 228	531 / 427	429 / 355	335 / 285
	25	369 / 315	296 / 258	228 / 203	520 / 440	418 / 361	323 / 286	655 / 549	527 / 453	409 / 359
	35	421 / 367	337 / 299	260 / 234	595 / 513	476 / 419	368 / 331	749 / 643	603 / 527	467 / 417
	40	443 / 389	354 / 316	273 / 248	626 / 545	501 / 445	387 / 350	790 / 683	635 / 559	491 / 441
	45	464 / 409	371 / 332	285 / 260	656 / 574	524 / 468	404 / 367	829 / 721	665 / 589	513 / 463
Flow per 100' (GPM/GPH)		0.67 / 40	1.02 / 61	1.53 / 92	0.44 / 26.67	0.68 / 41	1.02 / 61	0.34 / 20	0.51 / 31	0.77 / 46

Additional flow of 0.4 GPM required per lateral to achieve 0.5 fps.  
 Additional flow of 0.8 GPM required per lateral to achieve 1.0 fps.

**BIOLINE DOSING CHART Maximum Length (feet) of a Single Lateral (1.5 & 2.0 fps)**

Dripper Spacing		12"			18"			24"		
Dripper Flow Rate (GPH)		0.4	0.6	0.9	0.4	0.6	0.9	0.4	0.6	0.9
Flushing Velocity (fps)		1.5 / 2.0	1.5 / 2.0	1.5 / 2.0	1.5 / 2.0	1.5 / 2.0	1.5 / 2.0	1.5 / 2.0	1.5 / 2.0	1.5 / 2.0
Inlet Pressure (psi)	15	201 / 161	171 / 141	140 / 119	275 / 217	235 / 191	194 / 164	337 / 263	289 / 233	241 / 201
	25	266 / 221	222 / 190	179 / 157	366 / 302	308 / 261	251 / 218	453 / 369	383 / 321	313 / 270
	35	316 / 269	262 / 229	210 / 187	437 / 370	365 / 316	295 / 260	543 / 455	455 / 391	369 / 324
	40	337 / 290	280 / 246	223 / 200	469 / 399	391 / 340	313 / 278	583 / 493	487 / 421	393 / 347
	45	358 / 310	296 / 261	235 / 212	497 / 427	413 / 362	331 / 296	619 / 527	517 / 449	415 / 369
Flow per 100' (GPM/GPH)		0.67 / 40	1.02 / 61	1.53 / 92	0.44 / 26.67	0.68 / 41	1.02 / 61	0.34 / 20	0.51 / 31	0.77 / 46

Additional flow of 1.2 GPM required per lateral to achieve 1.5 fps.  
 Additional flow of 1.6 GPM required per lateral to achieve 2.0 fps.

**BIOLINE DOSING CHART Maximum Length (feet) of a Single Lateral (2.5 & 3.0 fps)**

Dripper Spacing		12"			18"			24"		
Dripper Flow Rate (GPH)		0.4	0.6	0.9	0.4	0.6	0.9	0.4	0.6	0.9
Flushing Velocity (fps)		2.5 / 3.0	2.5 / 3.0	2.5 / 3.0	2.5 / 3.0	2.5 / 3.0	2.5 / 3.0	2.5 / 3.0	2.5 / 3.0	2.5 / 3.0
Inlet Pressure (psi)	15	128 / 102	115 / 94	100 / 84	172 / 136	155 / 127	136 / 113	205 / 161	187 / 151	165 / 137
	25	183 / 151	161 / 136	137 / 118	248 / 203	220 / 184	188 / 161	301 / 245	268 / 223	231 / 197
	35	228 / 193	198 / 171	166 / 146	310 / 260	272 / 232	229 / 200	379 / 315	333 / 283	283 / 245
	40	248 / 211	214 / 186	178 / 158	338 / 286	295 / 254	247 / 218	413 / 347	362 / 311	305 / 267
	45	266 / 228	229 / 200	190 / 169	364 / 310	316 / 274	263 / 233	447 / 377	389 / 335	327 / 287
Flow per 100' (GPM/GPH)		0.67 / 40	1.02 / 61	1.53 / 92	0.44 / 26.67	0.68 / 41	1.02 / 61	0.34 / 20	0.51 / 31	0.77 / 46

Additional flow of 2.0 GPM required per lateral to achieve 2.5 fps.  
 Additional flow of 2.3 GPM required per lateral to achieve 3.0 fps.

**Table 11 - Maximum Length of a Single Lateral of Bioline Based on Flushing Velocity**

## **DRAINBACK CONSIDERATIONS**

When the dosing cycle ends, much of the remaining effluent will drain out of the dripline at or near the closest dripper. (Every 100' of Bioline only holds 1.33 gallons so the small amount of effluent left in the dripline after shutdown that can drain out of the tubing drains with some evenness over the length of the dripline with little chance for ponding or surfacing.). While this is not a concern with relatively flat areas and areas with subtle rises and-falls, special attention needs to be given to slopes steep enough to create a gravity-driven flow that could force effluent into low areas and thus overload the area or areas with fine textured soils less likely to be able to accept additional flow. To combat this, there are a number of design approaches that address this issue, but the important thing to remember is that caution should be taken to ensure that draindown of the effluent toward the bottom of slopes is minimized.

One of the reasons why Bioline dripperline is a good solution on slopes is due to its pressure compensation feature. Bioline drippers deliver the same flow from 7 to 58 psi, so changes in pressure at the dripper due to elevation-created pressure variances do not affect the delivery rate of the drippers.

Other products allow additional flow anywhere higher pressures exist and as such, the soil can become saturated very quickly at the base of the slope. With Bioline, all areas of the slope are dripped at the same rate. There is no need to increase field size with Bioline. Simply use as much of the slope as possible to deliver to. (See Figures 11 & 12).

**Install With the Contour:** Drinkerline must be installed along the contour of the slope (as level as possible), not up and down the slope. Otherwise, all the effluent in the dripperline will drain rapidly to the emitters at the base of the slope, which can overload the soil.

**Feed from the Bottom of the Field:** As a rule, drip fields on a slope should be fed from the bottom. This technique will prevent the main lines and manifolds from draining to the field during rest periods. This strategy assumes that the field is uphill from the supply line. The supply manifold should "stair step" through a series of check valves, with a limited number of lines between each check valve. Check valves limit the down gradient flow of the water when the pump shuts down.

**Less Frequent, Longer Doses:** In more highly permeable soils with no restrictive conditions, longer dosing duration and decreased dosing frequency can help minimize the effects of drainback by reducing the number of cycles per day.

**Zone Valves Location:** To prevent mainline and submain drainage into the drip dispersal fields, zone valves should be installed as close as possible to the distribution field to minimize the volume of effluent subject to drainback. Local regulations often prohibit effluent from mains and submains draining into the drip fields during periods of rest.

**Deeper Line Burial:** Another way to manage potential drainback issues and the chance of surfacing is to bury the dripperline deeper. While this is not an optimal solution, it will at least dose the effluent deeper into the soil.

## DOSING AND CONTROLS

The fundamental principle of drip dispersal is to take full advantage of the entire application area and to do so over the course of the entire day. Although most wastewater flows have peaks and valleys throughout the day, the goals of effective distribution are:

- Minimize soil saturation
- Encourage lateral (i.e., capillary) rather than gravitational flow of effluent
- Achieve uniform distribution
- Utilize the entire day (18-24 hours)

Historically, the cause of most drip system failures is not improperly designed drip fields, but rather an inadequate soil loading schedule. Experience has shown that even a flow as little as 200 gallons, dosed intensively, can cause a system failure in the same field that could accept 500 gallons, if dosed evenly throughout the day.

### Time vs. Demand Dosing

The goals above are best accomplished through effective dosing controls of an integrated system. A dosing control system is especially important on tight, shrink-swell clay soils, since these soils are very sensitive to overloading.

The function and complexity of the control system is determined both by the wastewater demand and the limitations of the soil. An effective control system considers the following:

- Unusual loading conditions
- Storage capacity
- Emergency storage/malfunction

There are two ways to dose effluent - demand and time. Demand dosing means that when a tank is filled to a certain point, a switch or other device signals the pump to turn on and the effluent is dosed into the drip field. That continues until the switch shuts off the pump.

Because the system must have adequate capacity to receive the flow and distribute it evenly over the course of the day, it is difficult to balance the dose rate and the rest time between doses with a demand system. Tank sizing issues become a critical component because depending on its size, it may lead to too frequent doses or doses that operate too long.

This is the essence of time dosing - pumping the effluent out at specified intervals throughout the day rather than simply letting it flow out at the same time it is generated.

Timed dosing provides a collection system and timer that allow a specific amount of dosing to be done at prescribed times throughout the day. This system is the best way to ensure that the soil is being dosed at the proper rate and that enough time elapses between doses for the soil to manage the effluent.

## **RECOMMENDED DRIP DISPERSAL OPERATION CONTROLS**

An electronic control system is essential to the proper operation of a drip dispersal system. The controller must be able to schedule the dosing cycles, turn the dosing pump(s) on and off, and may also schedule and control the field flushing and filter backflush operations.

While some controllers manage a very sophisticated "headwork" that doses, forward flushes the dripperline, backwashes the filters and manages one or several zones, it could also be a more simple control panel that performs the dosing cycles, turns the pump(s) on and off and is paired with a headwork unit that is a "continuous flush" unit providing forward flushing water back to the treatment system whenever dosing is occurring.

The breadth of control philosophies are only limited by the creativity of the designer, the price that the owner is willing to pay and the local regulations.

## **SEQUENCE OF OPERATION**

Netafim does not offer control packages because many companies already offer standard and customized controls to meet any design criteria or specification. The following describes the general approach and various levels of control for a residential and small commercial system. Always consult local codes for specific control requirements.

System controls should be sophisticated enough to ensure that a sufficient volume of effluent is present in the dosing tank to allow a time dose to occur and that will stop the dose event if the level falls below a sufficient volume.

Time Dose control panels are available for use with two, three or four float combinations. In a two float system, one float in the tank is the "low level cutout" float while the other is a "high level alarm" float. The normal operating level should be between the "low level cutout" position and the "high level alarm" position.

Time Dose panels can be installed with a choice of three float systems. One choice adds a "redundant off" float which is positioned slightly below the "low level cutout" grey float, but above the pump. The normal operating level is between the "low level cutout" position and the "high level alarm" position. The other three float choice adds a "timer override" float which is positioned between the "low level cutout" and the "high level alarm" float. Normal operating level should be between the "low level cutout" float and the "timer override" float.

The four float system includes a “redundant off” float, a “low level cutout” float, a “timer override” float and a “high level alarm” float. The “timer override” float gives you the option of pumping from the basin while the timer is in the “off” cycle. It is only intended for times of abnormally high liquid level intrushes. The normal operating level should be between the “low level cutout” float and the “timer override” float. The control panel usually begins timing in the “off” sequence when the “low level cutout” float is activated. Once the timer completes the “off” sequence, the timer will start the pump and continue to run until the programmed “on” sequence is complete. At this point, the “off” sequence begins timing again and the cycle repeats.

In addition to turning the pump on and off at specified times, the control system typically enables the cleaning of filters and field flush.

## HOW TO DOSE

Before we get too far into dosing, we need to agree on the volumes associated with a dose tank, what constitutes a single dose and what constitutes a flush dose, as well as some background on dose tank sizing.

**Dose Tank:** The dose tank acts as the storage vessel to accumulate effluent that will be dosed into the drip field. Once the effluent reaches a predetermined volume or a preset time, it is pumped to the field. The major difference between a septic tank and a dosing tank is that the dosing tank volume will be lowered on a daily basis.

Avoid oversizing the dose tank because it can be difficult to achieve adequate switch separation for the pump control.

There are different methods for sizing the dose tank. Netafim does not offer specific dose tank sizing criteria. The information provided is only a guide. Refer to local regulations for proper sizing.

### Method 1:

Add the following elements together:

- The sum of the dosing volume
- The volume of the delivery pipes
- The volume needed to keep the pump submerged
- Emergency storage volume in case of pump failure. (A minimum of one-day emergency storage above the high water alarm is a frequently used value).

### Method 2:

<i>RECOMMENDED DOSING TANK SIZE</i>	
<i>Based on Bedrooms</i>	
<i>Number of Bedrooms</i>	<i>Minimum Dosing Tank Size (gallons)</i>
1	250
2	250
3	500
4	500
5	750

**Table 12 - Recommended Dosing Tank Size Based on Bedrooms<sup>8</sup>**

<sup>8</sup> Converse - 1978.



**Method 3:**

- Equal to what would be required for a septic tank
- Should provide 1 - 2 days average flow equalization volume
- On tough sites, increase the size to ensure that the amount of peak flow dosing is minimized
- These size systems usually work with pretreated effluent
- Engineers have guidelines on what is adequate
- The dose tank needs some emergency storage above high water and minimum equalization storage for dosing, 1/3 to 1/2 of the daily flow
- Equalization in the whole train should exceed one day's flow

## DOSE AND FLUSH VOLUMES

**Volume of a Single Dose:** Many designers and regulators have established dosing times based on dosing a minimum number of drip tubing volumes through the emitters (after pressurization).<sup>9</sup> This ensures that the dosing cycle is long enough to get good distribution of the wastewater into the soil. An effective minimum dose is generally regarded to be 4 to 6 times the liquid capacity (volume) of the drip laterals. Refer to local codes.

**Volume of a Forward Flush or Flush Dose:** As we discussed earlier with flushing velocities, the volume of a flush dose is subject to designer interpretation. In general, and subject to local codes, it should be at least equal to or greater than twice the void volume of all pressurized piping.

**Dosing Do's and Don'ts:**

- Do not overdose. Effective drip dispersal relies on the slow, even application of effluent to the field.
- Dosing too little could lead to unequal effluent distribution.

<i>HOLDING VOLUMES in Gallons for Pipe</i>		
<i>Pipe Size</i>	<i>Per Foot</i>	<i>Per 100 Feet</i>
Bioline	0.0133	1.33
1"	0.04	4
1 ¼"	0.07	7
1 ½"	0.1	10
2"	0.17	17
2 ½"	0.24	24
3"	0.38	38
4"	0.65	65

**Table 13 - Holding Volumes for Various Pipe Sizes**

<sup>9</sup> Reference - TVA Wastewater Subsurface Drip Distribution Report, May 2004. Footnote 63, page 5-26.

# WASTEWATER REUSE AND DRIP DISPERSAL GUIDE

---

**Determining Dosing Requirements:** The following provides the conceptual basis for sizing the drip field, setting up zones and designing the pump control system. A computer spreadsheet of this process is available on the Netafim Wastewater Division CD.

1. How many gallons per day (**GPD**) is the wastewater load?  
*Refer to "Typical Wastewater Flows" on page 8 if there is no local rule or criteria.*
2. What is the **Soil Loading Rate** in gallons per sq. ft. per day?  
Check local rules and "Soil Loading Rate Chart" on page 18.
3. Calculate dispersal area.  
 $Gallons\ per\ day\ (GPD) \div Loading\ Rate\ (GPD/sq.\ ft.) = Application\ Area\ (sq.\ ft.).$
4. Calculate **Total Linear Length of Tubing**.  
*Divide the Application Area by two to get the total linear length of drip tubing (this assumes two foot row spacing between the dripperlines. Divide by 3 for 3 foot spacing, etc.).*
5. Select **Dripper Flow Rate** and spacing based on soil type.  
Bioline is available in flow rates of 0.4 GPH, 0.6 GPH (most common), and 0.9 GPH. Heavier soils usually indicate lower flow rate drippers, either 0.4 GPH or 0.6 GPH.
6. Calculate **Total Flow Rate** of all tubing.  
Use the chart "Flow Rate per Length of Tubing" on page 5, or the following formula:  
 $Flow\ Rate\ of\ Dripper \times Total\ Linear\ Length\ of\ Tubing \div Dripper\ Spacing\ (ft.) = Total\ flow$   
*For example:*
  - Bioline with 0.6 GPH drippers at 2 ft. spacing between drippers
  - For each 1,000 feet of drip tubing, the flow would be:  $0.6 \times 1000 \div 2 = 300$  gallons per hour (GPH) = 5 gallons per minute (GPM) [GPH  $\div$  60 = GPM].
7. Determine the **Number of Zones** needed by pump size consideration.  
Zones should generally not exceed half the rated volume of the pump.
8. Calculate **Total Flow Rate per Zone** in gallons per minute (GPM).  
Total flow rate of all tubing  $\div$  number of zones.
9. Calculate **Number of Minutes of Total Run Time** based on daily flow.  
$$\frac{Total\ Daily\ Load\ (GPD)}{Number\ of\ Zones}$$
10. Calculate **Number of Minutes per Zone**.  
$$\frac{Total\ Minutes}{Number\ of\ Zones}$$
11. Select **Dosing Duration** based on soil conditions (6 to 12 minutes):  
Typically, heavier soils should have shorter dosing durations.
12. Determine **Number of Dosing Events**:  
Number of minutes of total runtime  $\div$  dose duration (minutes).
13. Calculate **Time Between Dosing Events**:  
Based on an 18 hour day (check local regulations). Time between dosing events =  
$$\frac{18}{Number\ of\ Doses\ plus\ 1}$$

## FILTERS AND FILTER CLEANING

The filter is designed to capture particles larger than can safely pass through the drip emitters. The most common filtration methods in use today in onsite systems are:

- Screen
- Disc
- Media

**Screen Filters:** Screen filters are the least sophisticated filters for use in onsite systems because they are the most likely to allow debris to pass through them. This is especially true of organics which can change shape and be squeezed through the filter during operation. Screen filters also have a much smaller surface area than other types of filters which increases the frequency of cleaning. In general, screen filters only capture about 65% of the debris at or above its stated micron size and the cleaning operation is difficult because the debris is typically wedged into the spaces of the screen. This means that the screen cannot be effectively surface flushed. It needs to be removed and physically scrubbed and it is very difficult to remove the debris jammed into the screen.

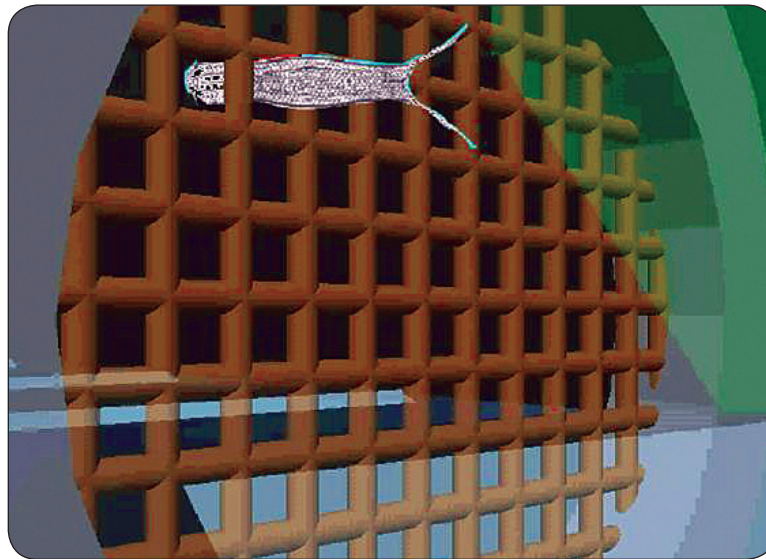

**Figure 13 - Screen Filter with Debris Passing Through**

*This picture illustrates how debris can easily pass through the single layer structure of a screen filter.*

**Disc Filters:** Disc filters fall into the category of "depth" filters because they add an additional dimension to the cleaning process. Disc filters use an overlapping series of grooves that force the effluent to move through a series of trap points. This process increases the likelihood of debris capture to 90% - 99%. Because of the increase in filtration surface area, the frequency of cleaning drops and cleaning is easier.

Netafim recommends disc filtration for standard residential and small commercial onsite wastewater drip dispersal systems.

**Media Filters:** Media filters offer the greatest protection against both organic and inorganic debris. In a media filter, raw water is introduced into a filter chamber that is filled with a media such as sand and is allowed to pass through the media bed. The media does an excellent job of capturing the debris and is superb at delivering highly filtered water. In applications where even finer filtration is required, varying types and layers of media can be

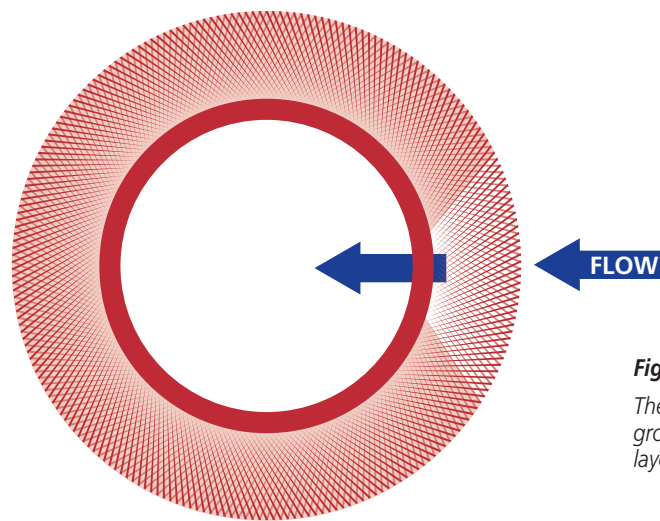

**Figure 14 - Disc Filter Ring**

*The intersection points between the grooves of adjacent discs create multi-layered depth filtration.*

added to capture even very small debris. While a very effective filtration method, the typical media filter is larger and more sophisticated than residential and small commercial projects require.

**Manual Filter:** A filter is placed in the supply line after the treatment system, downstream of the pump and upstream of the Bioline®. Cleaning the filter requires that the filter cartridge be removed and the disc and housing manually flushed clean.

**Timed Backflush:** This more sophisticated filtration cleaning normally has more than one filter and valve which are used in a configuration to clean one another automatically. The frequency of the backwash is controlled using a timer clock or dosing counter to automatically flush the filter. Filtered water from one filter is sent backward through another filter dislodging captured debris between the filter's discs. This backwash water is then returned to the treatment system and reprocessed.

**Pressure Differential Backflush:** This system is similar to **Timed Backflush**, but has the added component of a pressure differential switch or sensor. As debris in a filter increases, the pressure differential across the filter increases. A pre-set pressure difference across the filter triggers an automatic backflush. This can be the primary trigger for the backflush, or a back-up option for a regularly timed backflush.

If the system has a timed or pressure differential backflush, manual cleaning of the disc filter cartridge may still occasionally be required. This is especially true when a treatment and dispersal system is first started up to ensure that construction debris is removed.

**Disc Filter Cleaning:** All filters need to be taken apart, inspected and cleaned as necessary. Each disc surface has grooves that capture particles as they try to pass through the filter. It is necessary to separate the discs and clean the entire filter element using a garden hose, or other pressurized stream of water. If deposits form on the discs that cannot be easily removed by mechanical means, muriatic acid can be used (in a 10:1 ratio of water to acid, following all safety instructions on the acid container).

## FIELD FLUSH

Netafim Bioline® dripperline is designed to last for many years. Although filtration is taking place, small particles (under 130 microns) can still enter the tubing. Over time, these particles may accumulate. As such, it is recommended to field flush the system.

As discussed earlier, "field flushing", "forward flushing" or "scouring" is accomplished by either continuously flushing or by periodically opening the flush line from the drip field back to the pretreatment or dosing tank. In this process, the velocity of water moving through the tubing is increased to a rate of speed (velocity) that breaks any debris build-up free from the walls of the piping network and sends it back to either the dose tank (when doing continuous flush) or the beginning of the treatment system (when doing intermittent flush). The dirtier the water, the higher the recommended flush velocity and frequency be. To prevent an accumulation of debris in the dripperline, it is recommended that field flushing take place on a regular basis. Field flushing should be done at least several times per year, but the system may be designed with a simple continuous flush headwork that allows a constant flow of water back to the dose tank, thus providing for a continuous scouring action<sup>10</sup>. The required rate will depend on many factors. Among these are:

- Effluent quality and characteristics
- Filtration efficiency
- Length of tubing in each zone
- Local regulations for maintenance

## ROOT INTRUSION

The unique design characteristics of the Bioline emitter provide an effective physical barrier against root intrusion without the addition of root inhibiting chemicals. Bioline® dripperline has a **Full Ten-year Warranty** against clogging due to root intrusion.

If local regulations require the addition of a root intrusion inhibiting chemical, or if the designer or system owner or operator want an extra measure of assurance, Netafim can provide the Techfilter® System. Techfilter incorporates a replaceable filter element embedded with trifluralin<sup>11</sup>, an effective root inhibiting chemical used extensively in agriculture.

As water passes through the filter, a very low concentration of trifluralin (parts per billion) passes through the system. This technology provides very precise and even distribution of trifluralin throughout the piping network which is not possible when the dripper is impregnated with the chemical.

Unlike other products, Techfilter eliminates skin irritation from the chemical during handling, and does not require that tubing be stored in a dry, cool building out of the sun.

Techfilter® is designed to provide renewable protection because the chemical is both heat and time sensitive. As it loses its effectiveness over time, it can be replaced, and as such, when prescribed maintenance of the Techfilter is performed, a limited **Lifetime Warranty** against root intrusion is available.

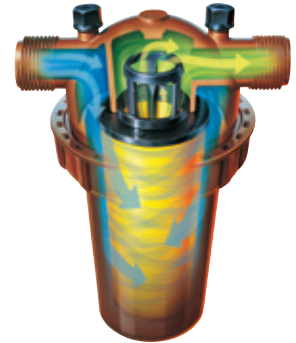

---

<sup>10</sup> See the earlier discussion on this topic.

<sup>11</sup> Trifluralin stops cell division in any root tip that comes into an area where the chemical is present.

## INSTALLATION

### SITE PREPARATION

The drip field should be viewed as a wastewater dispersal field and many of the same considerations for conventional septic drain fields should apply. These limitations include:

- No future expectation of building(s), decks, or other impervious surfaces
- No long term storage of equipment or vehicles over the site
- A permanent vegetative cover
- Winter dormant grasses are over-seeded with winter grasses when possible

### DRIP TUBING INSTALLATION

One of the prime benefits of Bioline® is its ability to deliver effluent at a prescribed rate into the biologically-active layer of the soil that supports the roots of plants, trees and turfgrass. In conjunction with the effluent-purifying capabilities of the soil, the root systems provide valuable uptake of the effluent as well.

To maximize the soil's biological activity, the drip tubing will normally be installed 8 to 12 inches below the soil surface. Check local codes for depth of burial.

Colder climates may require deeper placement or additional cover to avoid freezing during periods of inactivity.

Where conditions allow, manifold trench depth should be the same as the dripperline depth in order for the air/vacuum relief valves to work most effectively. In freezing climates, manifolds may have to be placed below the frost line.

Dig the manifold trenches wide enough to provide sufficient working room to cut and fit tees and to insert the flex connectors between the manifolds and the tubing. Allow enough room to work. Always avoid installing drip tubing in wet soil.

#### Three common ways to install the Bioline drip tubing:

**Plowing:** Installed much the same way as TV cable, plowing refers to knifing in the dripperline through use of a vibratory plow. This method is increasingly common because the process does not disturb the soils and smearing is uncommon.

Netafim works closely with Vermeer Manufacturing Company and together they have developed a vibratory plow that efficiently installs several rows of Netafim Bioline at once.

The process, called Conservigation® is exclusive to Netafim and is the most sophisticated installation process on the market.



**Figure 15 - The MB-40 Multi-Blade Vibratory Plow.** Shown here with three 1,000' rolls of Netafim Bioline® attached to the versatile Vermeer® LM-42 power unit. This unit has a variety of attachments and fits into narrow areas.

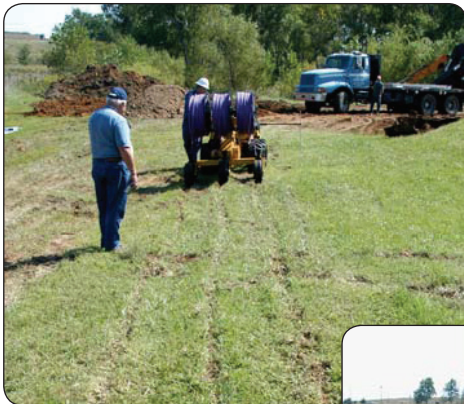

**Figure 16 - MB-40 Minimizes Damage to Existing Landscape.** Thanks to its unique design, the MB-40 quickly rake-up of this area, the rows virtually disappear.



**Figure 17 - MB-40 Does Not Disturb the Grade.** Even in bare dirt.



**Figure 18 - MB-40 Can Be Mounted on the Vermeer® RTX-450.** This ride-on unit is excellent for large installations.

**Trenching:** This method uses commonly available trenching machines to cut narrow trenches for tubing installation. The advantages of this method are that trenchers are widely available and easy to use. The disadvantages are that the trench may leave wall surfaces that are "slicked" and therefore less receptive to horizontal water flow. Trenching will damage existing vegetation; the trenches must be filled with original materials, properly compacted, and watered in from the top down.

**Fill or "Drip and Fill":** In this method, the dripperline is laid on the ground and fill material is placed over it. If there is any vegetative cover, it should be removed and the original soil scarified (plowed or deep-raked) to minimize any variances in soil types. If soils of different textures are used, the constraints discussed in the Soils Section must apply. It is recommended that the fill material be the same as the original.

Other tips when using imported soil include:

1. Use soil with a clay content not exceeding 20%
2. Harvest, ship and place the soil only under dry conditions
3. Remove all debris, roots and other coarse fragments or rocks
4. Put the soil in place in 6" - 8" increments

Netafim has a technical paper titled "Guidelines for Using Imported Soil" in the literature download section of the Netafim Wastewater website. It contains important information to consider when using imported soil.



**Figure 19 - "Drip and Fill" Technique.**

The dripperline is laid out across the drip field and fill material is then placed over the dripperline to the prescribed depth.

**Figure 20 - Mechanized Equipment** May be used to spread soil over the top in larger systems. It is important to evenly spread the soil moving *with* the tubing direction to keep the laterals from shifting.





For all methods, it is important that the disturbed soil above the dripperline be the approximate texture and compaction as the soil around the dripperline. This will avoid creating a preferential pathway of the effluent to the surface, also known as the "Chimney Effect". Careful, manual compaction of the soil above the dripperline may be advisable when the tube has been trenched or plowed in (local codes permitting).

**NOTE: Avoid excessive mechanical stress on the tubing before, during, and after installation.**

## PIPING HOOK-UP

The supply and flush lines, and the supply and flush manifolds are installed using standard techniques for PVC piping. Medium body (not fast drying) PVC cement is generally preferred.

Use the primer and cement as recommended by the manufacturer.

The installer should use a good quality, ratcheting type PVC cutter to prevent PVC filings from getting into the distribution lines.

## OPERATION AND MAINTENANCE

### START-UP

The designer should take precautions to troubleshoot the system and ensure that it is working properly over an initial startup period, typically 2 to 3 weeks.

Do not start the system with a massive dose. This can cause preferential water passages, or chimneys, that allow the effluent to surface and saturate the soil. If this happens, it may take some time to recover the drip field.

Construction debris (PVC scraps, glue remnants, soil, etc.) found in the piping network needs to be flushed. This flushing should not be done through the dripperline but rather before the dripperlines are connected to the headers. If the dripperlines are already connected to the headers, do not exceed the scheduled dosing cycle while flushing.

The pump tank or treatment system may be full of water after installation. Do not simply run it out through the drip tube. Either use the dosing schedule to empty the tank or set up a sprinkler, but always follow local codes as they apply.

If the dosing field is extremely dry, it can be advantageous to run a sprinkler on the surface to initially dampen the field.

### ROUTINE MAINTENANCE

Service and maintenance of the system should be coordinated with any regulatory requirements for monitoring of the onsite system. Most states have regulations that specify a routine maintenance schedule for advanced onsite wastewater treatment systems.

When a drip dispersal system is properly sized, designed, and installed, it should operate with little maintenance and easy monitoring. In addition to the fundamental design considerations already outlined, several other installation steps will simplify maintenance. These include:

1. Provide nipples for Schrader valves (tire gauge stems for measuring pressure) on critical piping elements (pump output, supply and flush manifolds, inlet and outlet of filters, etc.) in valve boxes to provide easy measurement of system pressure.
2. Maintain access to a short length of drip tubing for inspection.
3. Keep a detailed plot plan, system diagram, and wiring diagram readily accessible in the control panel.

4. Establish a service record chart to record:
  - **Pressure at:**
    - Pump
    - Supply line or manifold
    - Flush line or manifold
    - Other critical points
  - **Schedule:**
    - Dosing
    - Filter flushing
    - Field flushing
5. Monitor any changes in the number, activities, and water usage patterns of members of the household.

With this information framework, a system inspector can quickly and easily determine if the system is operating within specifications. If problems are identified by changes in pressure or flow, they can be located and corrected easily using information in the plans and locations of valve boxes.

## TYPICAL LAYOUTS

### TYPICAL LAYOUTS FOR RESIDENTIAL AND SMALL COMMERCIAL SYSTEMS

The layout for a typical residential onsite system is comprised of several components. In the following illustrations, each design scenario will contain all or part of the following components and systems:

- Secondary treatment system - advanced treatment unit, recirculating sand filter, peat system, fixed film, or wetland system, etc.
- Pump or dosing tank with water level sensors
- Pump
- System controller for pump operations, zone control, dosing scheduling, dosing tank monitoring, filter backflushing, field flushing and alarms
- Automatic or manual disc filter (130 micron / 120 mesh) set in an access box
- Air/Vacuum Relief Valves
- Zone Control Valves - Water actuated, motor driven or solenoid activated hydraulic valve
- Underground PVC piping, often 1¼" mainline, header and return lines
- Flexible PVC connectors and loops
- Mainline and supply header
- Flush manifold and return line
- Check valves
- Bioline® drip dispersal tubing

The following layouts illustrate some of the ways that drip dispersal fields can be laid out at a residence or small commercial complex. Use these drawings as guides only. Each system will have special circumstances that will require the designer to modify these typical layouts in order to adapt to the site. The following are basic considerations that should be taken prior to beginning any design:

- Shape of the proposed drain field
- General slope or direction of rise and fall of the site
- Location of property lines, buildings, trees, wells, water lines, gas lines, buried power lines, swimming pools, etc.
- Soil type including profiling to determine depth to most restrictive layer and or water table

# WASTEWATER REUSE AND DRIP DISPERSAL GUIDE

- Location of treatment system
- Location of power outlets or breaker
- Location of old drain field if the new system is a retrofit

## OPPOSING MANIFOLD LAYOUT

Rectangular field with supply and flush manifolds at opposite ends of dripperlines:

- Can be used where Bioline® lengths will be long and the drip field is narrow
- Bioline® laterals should never exceed recommended lengths

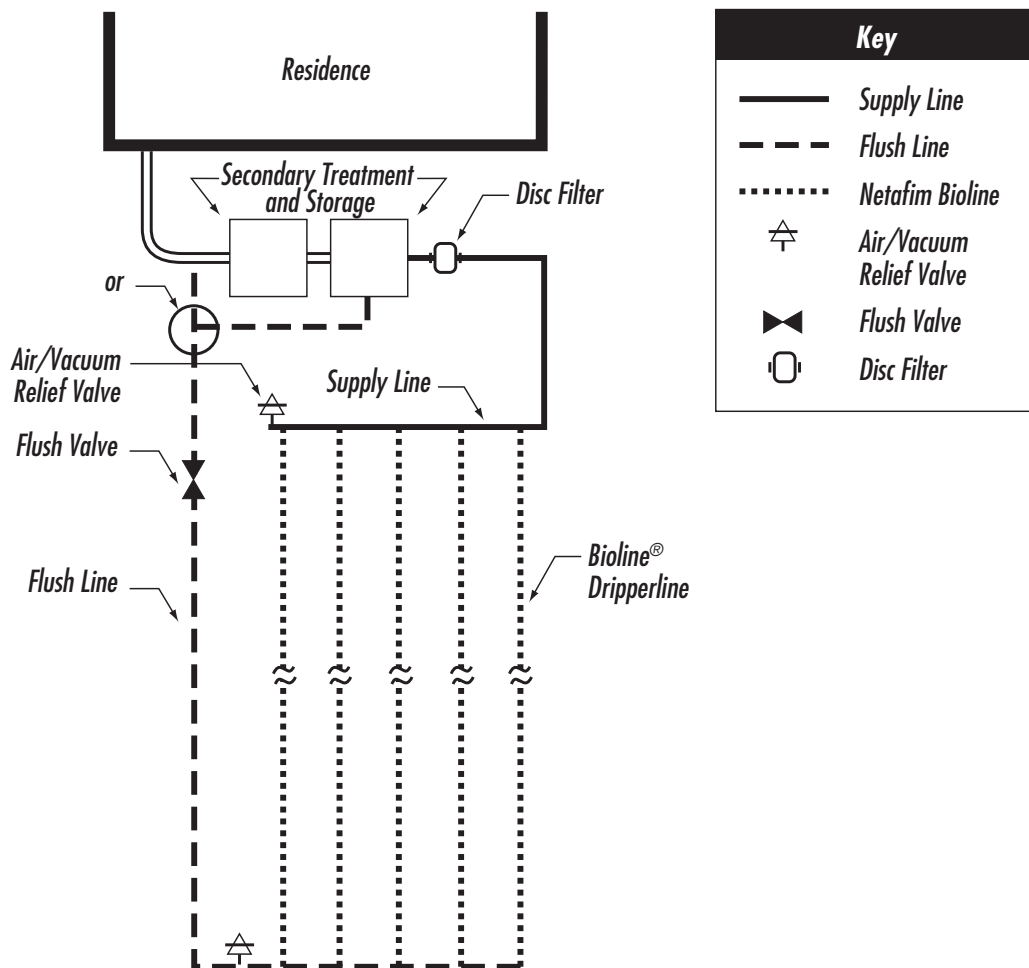

# WASTEWATER REUSE AND DRIP DISPERSAL GUIDE

## SINGLE TRENCH LAYOUT

Rectangular field with supply and flush manifolds on the same side and in the same trench:

- Locate the supply and flush manifolds in the same trench
- Dripperlines are looped at the halfway point of their run and returned to flush manifold
- Bioline® laterals should never exceed recommended lengths

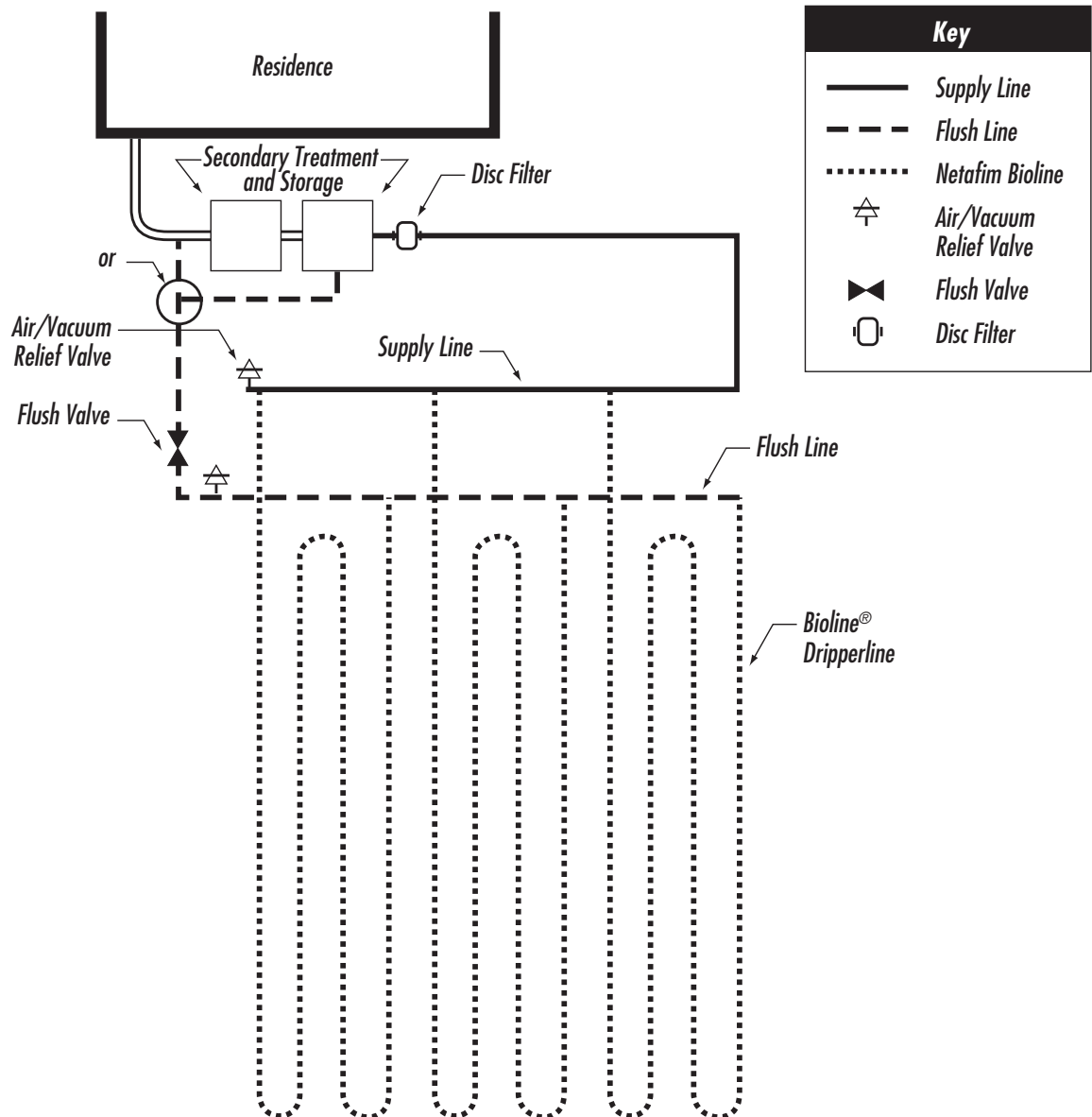

## IRREGULAR FIELD SHAPE LAYOUT

Triangular field with looping and varied positioning of flush manifolds:

- Used when site limitations dictate unequal dripperline length with respect to dispersal field length
- Loop the Bioline® to increase lateral length and reduce the number of connections
- Keep the Bioline laterals as close to the same length as possible to provide for an equal field flush
- The flush manifold may be located on the same or opposite side of the supply manifold
- As pictured, it may be necessary to make one or more distal end connections to the flush line on an opposing side in order to balance dripperline lateral lengths and to limit the number of connections

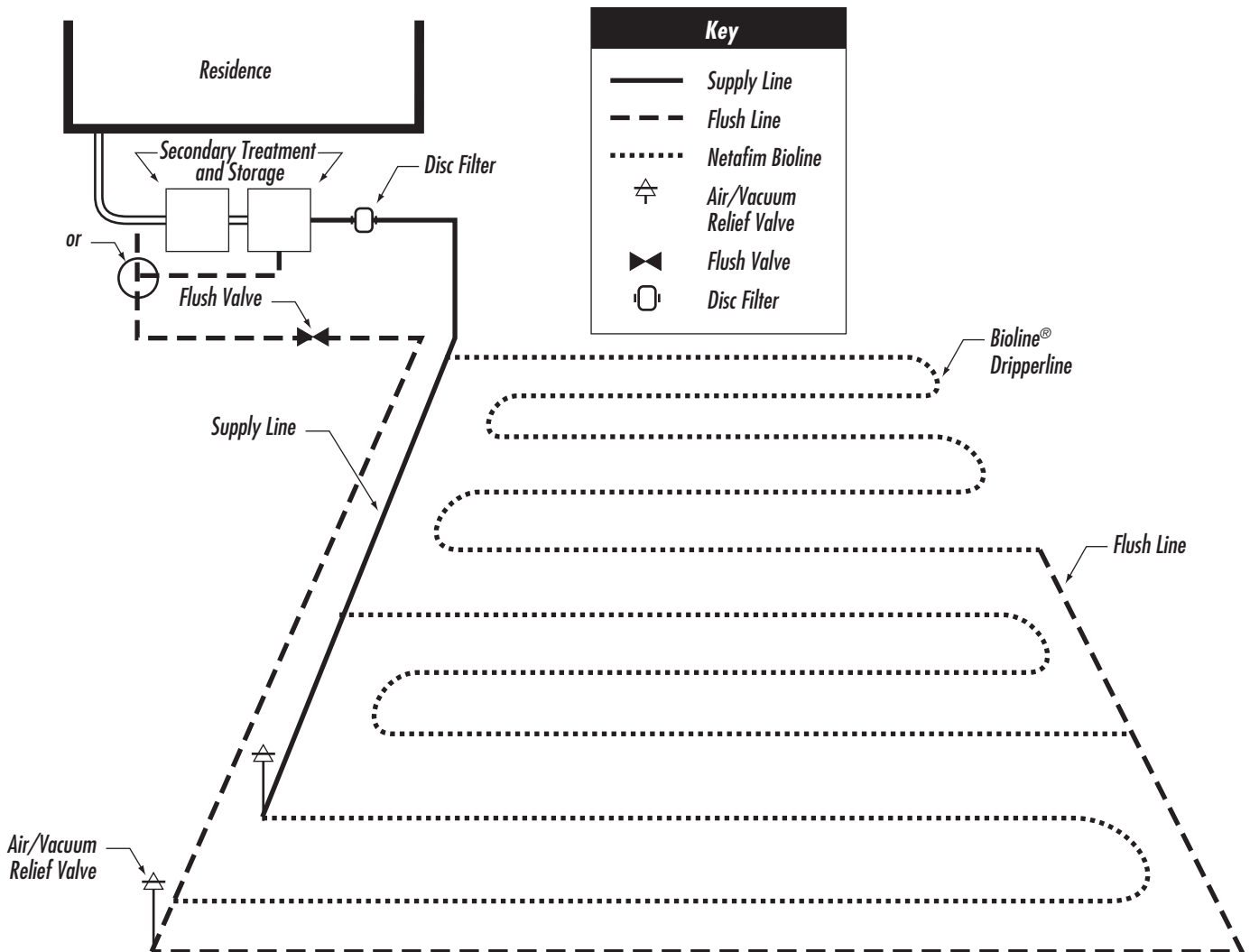

# WASTEWATER REUSE AND DRIP DISPERSAL GUIDE

## MULTIPLE ZONE LAYOUT

Multiple zone system with looping laterals:

- Used for a variety of reasons including when:
  - Single zone accumulated Bioline® lengths exceed recommended pump flow rate
  - Soils require additional resting time between dosings
  - There is a potential need for expansion of the system, which is common in commercial systems. Second or subsequent zone may be left out until needed
- Additional check valves are needed to isolate each zone on the flush line side. An additional air/vacuum relief valve should be installed before the check valve on each zone
- Zone changes are typically accomplished using an electric valve and controller
- Zone layouts may be parallel systems or may follow any of the scenarios discussed
- Zones should have similar flows
- Controller must be capable of operating a multi-zone system

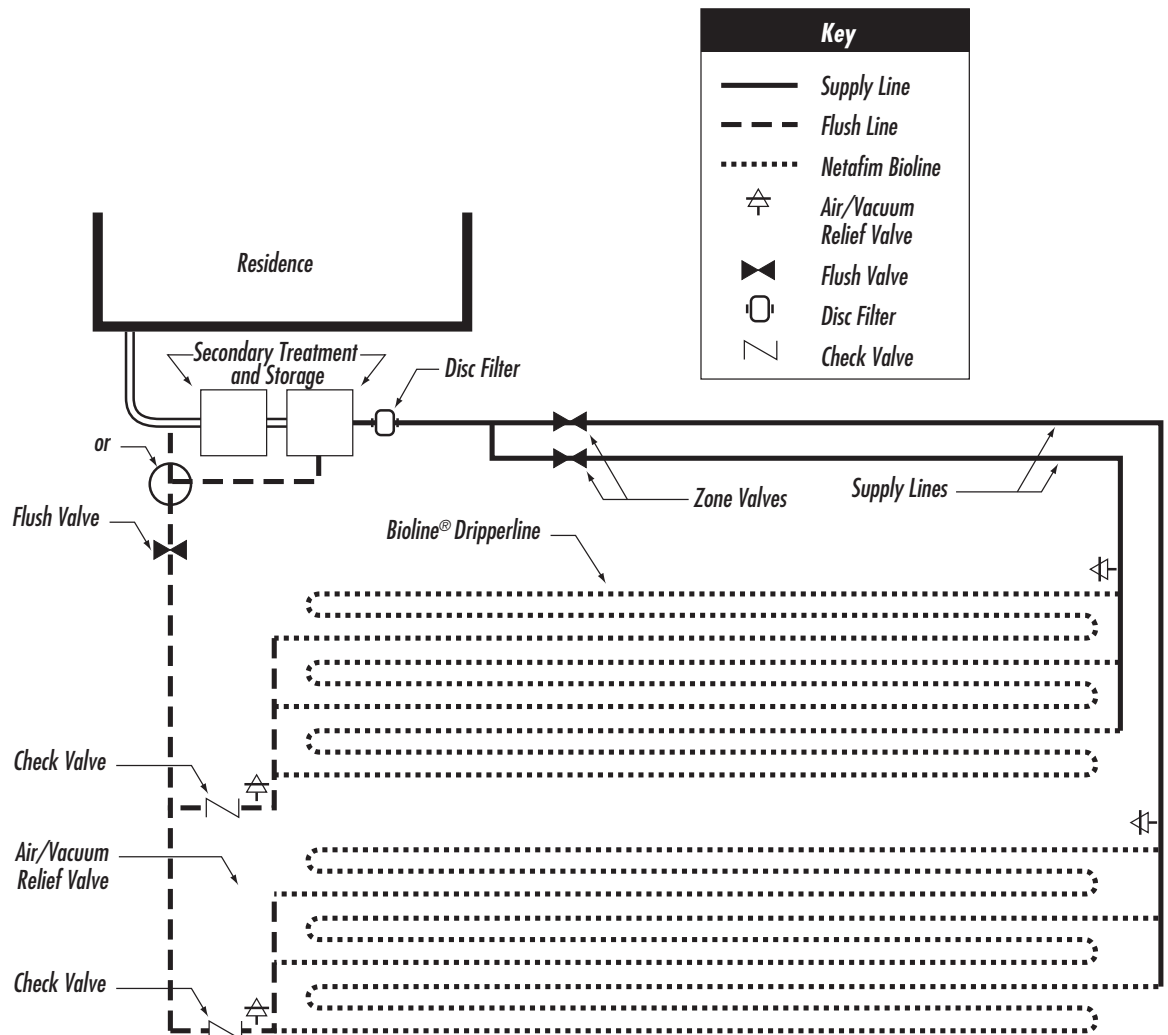

## **FREEZING CLIMATE DESIGN AND OTHER CONSIDERATIONS**

The goal of freezing climate designs is to be able to drain the entire system as quickly as possible - preferably in 10 to 15 minutes or less. Any pipe or component that does not drain after a dose must be buried below the frost line and/or properly insulated.

### **Landscape and Cover:**

1. Additional depth over dripperline:
  - a. Dripperlines that are buried deeper in the ground are less likely to freeze than shallow.
  - b. Whenever possible, add solid cover (soil) to increase the depth of the dripperline.
  - c. Note: It is better to have the dripperlines in the 6" - 8" range if possible for better nutrient removal, but this should be weighed against the climate.
2. Established and undisturbed wooded sites where trees have not been removed, have been shown to allow shallow systems to perform without freezing.<sup>12</sup>
3. Landscapes with drip dispersal fields should have vegetative cover over them. This may be prairie grass, plants, bushes, shrubs, trees, turfgrass or any combination.
4. Vegetative height should be at least 4" to 6".
5. In areas where warm season grasses go dormant:
  - a. The area should be overseeded to ensure sufficient ground cover.
  - b. Overseeding should begin as early as possible to allow enough growth.
  - c. Cover all areas with at least 6" of straw/hay until the cover is properly established.
6. Stop mowing operations as early as possible so grasses can grow as tall as possible.
7. Managing snow cover:
  - a. Because snow is an excellent insulator, provisions should be made to ensure that snow can stay in place over the drip field.
  - b. Use anything that will help the snow to accumulate and stay over the field, including snow fence or other fencing, stands of trees, bushes, hedges, or decorative grasses.
8. In windy areas it may be necessary to have more than turfgrass as a cover.
9. If it is not possible to grow a cover over the field, use at least 6" of straw/hay to cover the entire system. In areas/seasons with minimum snow cover, check the depth of the straw/hay during the season. Add more cover as needed.
10. Keep foot traffic away from the drip field, especially when it has a snow cover.

### **Headers and Dripperline:**

1. **Note:** Netafim Bioline® dripperline is made from low-density, linear polyethylene to weather the effects of cold weather. Due to its emitters, it will drain available effluent after dosing. Our design and operation efforts therefore are to protect the non-Bioline piping network, fittings, valves and hard/rigid components that can break or fail if frozen.
2. Manifolds and supply/return lines should be installed lower than dripperlines to provide positive drainback after the zone shuts off.

---

<sup>12</sup> Mokma, D.L., T.L. Loudon & P. Miller. 2001 Rational for shallow trenches in soil treatment systems. In: Onsite Wastewater Treatment. Proceedings of the 9th National Symposium on Individual and Small Community Sewage Systems. ASAE. 2950 Niles Road, St. Joseph, MI. [www.asae.org](http://www.asae.org)

# WASTEWATER REUSE AND DRIP DISPERSAL GUIDE

---

3. Manifolds and supply/return lines should be sloped back to the tank to provide positive drainback.
4. Under extreme conditions, manifolds and supply/return lines should be buried below the frost line.
5. Consider insulating all manifolds and supply/return lines with Styrofoam board if the system is in an extremely cold location.
6. Any drain valves must be able to remain open long enough for the entire field to drain. Note: Hydraulically-operated valves may close when system pressure is too low.
7. Motorized drain valves may be installed to help drain the system in lieu of hydraulic valves.
8. Dripperline should be installed level across the contour of any discernible slope.
9. On laterals with blank tubing or flex connections, they may be installed slightly above the dripperlines. This will allow them to drain into the dripperline laterals.
10. Consider using larger piping on the supply and return lines to accommodate a high pressure nozzle and tubing along with clean out ports to gain entrance into the system. There are several brands of water jets on the market that can clear ice from inside the headers. They rely on warm water and its special nozzling allows it to move forward in the pipe as the stream of water dislodges any blockages.

## **Air Vents / Headworks / Valves / Valve Boxes:**

1. Install larger valve boxes than would normally be used to accommodate any service work that may be done in the winter.
2. Insulate all equipment boxes, including headworks boxes, filters, field flush valve boxes, as well as zone dosing valves and air/vacuum relief valves. Use Styrofoam panels or chips, or other closed cell insulating materials such as perlite or vermiculite in bags around the inside and the outside of valve boxes. If fiberglass is used, ensure that it cannot become waterlogged.
3. Install headworks and other components in risers over the treatment tank to capture available warmth.
4. Design the system around providing a continuous flush. This will keep water moving throughout the system during a dose and allow for fast draining on shutdown.
5. Insulate or add a heater to the headworks.
6. If using an index valve to split field zones, be sure it is capable of draining.
7. Air/Vacuum Relief Valves should be used liberally, and at least on the end of supply and flush manifolds.
8. Air/Vacuum Relief Valves should be placed below grade at any high point(s) and always above any dripperline laterals. The top of A/VRV must be no higher than the soil surface.
9. Attach and secure something metallic to the lid of valve boxes and A/VRV boxes to make them easier to find when they are covered with snow or vegetation.
10. Add a gravel sump of at least 6" under any valve box.
11. Grade away from all valve boxes to reduce groundwater incursion.

## **Installation:**

1. As noted above, dripperline laterals on any discernible slope should be installed as close to contour as possible.



## WASTEWATER REUSE AND DRIP DISPERSAL GUIDE

---

2. Due to potential shrinkage of the dripperline in cold weather, it should be installed so there is slack in the tubing. "Weaving" it back and forth if being installed in an open trench is an acceptable method.
3. If repairs are made to the system, keep the dripperline from becoming taut by adding sufficient tubing so the dripperline is not stretched.
4. Insulate the septic/treatment tank and pump tank to preserve whatever heat is inside.
5. All electrical components must be properly sealed to prevent condensation getting inside any controllers or panels.
6. Position and angle all filters to ensure that water does not get trapped inside.
7. Remove the check valve at the pump.

### **Operation:**

1. In multi-zone systems with lower flows in the winter, reduce the number of zones being used.
2. Reduce the time between doses, but do not overload the soil.

## **NETAFIM PRODUCT WARRANTY**

### **NETAFIM USA'S LIMITED WARRANTY/LIMITATION OF BUYER'S REMEDIES**

#### **(A) BASIC MANUFACTURER'S LIMITED WARRANTY:**

Except as to products described in Subsections (B), (C), (D), and (E) below, products sold and/or manufactured by Netafim Irrigation, Inc. (Netafim USA) are warranted to be free from original defects in material and workmanship for a period of one (1) year from the date of delivery to the buyer unless (i) otherwise specified by and subject to the terms and conditions of any Warranty Supplements pertaining to specific products or, (ii) expressly disclaimed in writing by Netafim USA. Within the warranty period, Netafim USA at its sole discretion shall have the option to repair or replace part or all of a defective product, or refund part or all of the original purchase price, if any part proves to be defective in material or workmanship after return of such product at customer's expense and after such return has been authorized in writing by Netafim USA. THIS BASIC MANUFACTURER'S LIMITED WARRANTY IS SUBJECT TO THE TERMS AND PROVISIONS IN SUBSECTION (F), (LIMITATION OF REMEDIES AND DISCLAIMER OF WARRANTIES) SET FORTH BELOW IN THE EVENT OF ANY INCONSISTENCY BETWEEN SUBSECTION (A) AND SUBSECTION (F) OF THIS PRODUCT WARRANTY, THE PROVISIONS OF SUBSECTION (F) SHALL PREVAIL.

#### **(B) DRIPPERLINES:**

Bioline dripperlines are warranted to be free from original defects in materials and workmanship for a period of five (5) years and seven (7) years for environmental stress cracking. Further, the Bioline warranty against emitter clogging due to root intrusion will be for a period of ten (10) years. This warranty shall apply only to products with a wall thickness of 35 mil or greater.

#### **(C) FILTERS:**

Disc filters are warranted to be free from original defects in materials and workmanship for a period of five (5) years. This warranty specifically excludes gaskets, seals and o-rings, which are subject to the basic one (1) year warranty.

#### **(D) VALVES:**

Valve bodies are warranted to be free from original defects in materials and workmanship for a period of five (5) years. Valve diaphragms are warranted for a period of two (2) years.

#### **(E) AIR/VACUUM RELIEF VENTS:**

Air/vacuum relief vent bodies are warranted to be free from original defects in materials and workmanship for a period of five (5) years. Polypropylene vent bodies are warranted for two (2) years. This warranty specifically excludes internal seals, gaskets or o-rings which are subject to the basic one (1) year warranty.

#### **(F) LIMITATION OF REMEDIES AND DISCLAIMER OF WARRANTIES**

EXCEPT AS EXPRESSLY PROVIDED HEREIN, ALL WARRANTIES EXPRESSED OR IMPLIED, INCLUDING ANY IMPLIED WARRANTY OF MERCHANTABILITY OR FITNESS FOR A PARTICULAR PURPOSE OR USE, ARE HEREBY EXCLUDED AND DISCLAIMED.

THE REMEDIES PROVIDED HEREIN SHALL BE THE EXCLUSIVE AND SOLE REMEDY OF THE BUYER. NO OTHER EXPRESS WARRANTY IS GIVEN AND NO AFFIRMATION BY NETAFIM USA, BY WORDS OR ACTION, WILL CONSTITUTE A WARRANTY. NO OTHER EXPRESS WARRANTY NOR ANY OTHER REMEDY SHALL BE AVAILABLE TO THE BUYER AND NETAFIM USA SHALL NOT BE RESPONSIBLE OR LIABLE FOR ANY DAMAGES, INCLUDING ANY LOSS OF PROFIT, LOST SAVINGS, LOSS OF SALES, OR OTHER DIRECT, INDIRECT, INCIDENTAL, SPECIAL OR CONSEQUENTIAL DAMAGES, INJURY OR DAMAGES TO ANY PERSON OR PROPERTY ARISING OUT OF THE USE OR INABILITY TO USE THE PRODUCTS OR THE BREACH OF ANY EXPRESS WARRANTY, EVEN IF NETAFIM USA HAS BEEN ADVISED OF THE POSSIBILITY OF THOSE

# WASTEWATER REUSE AND DRIP DISPERSAL GUIDE

DAMAGES OR CLAIMS. NETAFIM USA SHALL NOT BE RESPONSIBLE FOR THE AFORESAID DAMAGES, CLAIMS OR LOSSES DUE TO LATE DELIVERY OR DELIVERY OR NON-DELIVER, OR OTHERWISE. THERE ARE NO WARRANTIES WHICH EXTEND BEYOND THE DESCRIPTION AS SET FORTH HEREIN. IF NETAFIM USA SHALL FURNISH TECHNICAL ADVICE OR ASSISTANCE WITH RESPECT TO THE PRODUCTS SOLD HEREUNDER, IT SHALL BE GIVEN WITHOUT CHARGE TO BUYER AND SHALL BE GIVEN AND ACCEPTED AT BUYER'S SOLE RISK WITHOUT ANY EXPRESS OR IMPLIED WARRANTY AND NETAFIM USA SHALL NOT BE RESPONSIBLE OR LIABLE FOR THE ADVICE OR THE RESULTS THEREOF BUYER ASSUMES ALL RISK AND LIABILITY RESULTING FROM USE OF THE PRODUCT PURCHASED.

<b>WARRANTY INFORMATION</b>	
<b>Product Description</b>	<b>Warranty Length</b>
<b>Air Vent Bodies</b> Gaskets, Seals and O-Rings Polyethylene Bodies	<b>5 Years</b> 1 Year 2 Years
<b>Check Valves</b>	<b>1 Year</b>
<b>Disc Filters</b> Gaskets, Seals and O-Rings	<b>5 Years</b> 1 Year
<b>Bioline Dripperline</b> Environmental Stress Cracking, 35 mil/greater Emitter Clogging Due to Root Intrusion	<b>5 Years</b> 7 Years 10 Years
<b>Fittings</b>	<b>1 Year</b>
<b>Water Meters</b>	<b>1 Year</b>
<b>Pressure Regulators</b>	<b>1 Year</b>
<b>Valve Bodies</b> Valve Diaphragms	<b>5 Years</b> 2 Years
<b>All Products Not Listed</b>	<b>1 Year</b>

Table 14 - Product Warranty Chart

This warranty is expressly conditioned upon proper storage, installation, application and normal wastewater use and service as recommended by Netafim USA. Such recommendations may be updated from time to time. Any misuse, neglect, modifications, unauthorized repairs or replacement or uses of the product and/or any of its components for purposes not recommended by Netafim USA, including but not limited to the following, shall completely void this warranty:

- (I) Water which has not been filtered or treated to the levels specified for individual components of the product by Netafim.
- (II) Chemical concentrates, used or applied internally or externally to the product, or mechanical abuse which is harmful to the product or its components.
- (III) Operating pressures greater than those specified by Netafim's individual component specifications.
- (IV) Damage or plugging caused by insects, rodents, other animals, improper installation or other mechanical damage.

THE EXPRESS WARRANTY PROVIDED HEREIN IS EFFECTIVE ONLY IF CLAIM IS MADE BY WRITTEN NOTICE WITHIN THE APPLICABLE WARRANTY PERIOD AND POSTMARKED WITHIN THIRTY (30) DAYS AFTER DISCOVERY OF THE DEFECT ON WHICH THE CLAIM IS BASED. SUCH NOTICE SHALL BE DELIVERED TO NETAFIM USA AT THE FOLLOWING ADDRESS:

**NETAFIM USA  
5470 EAST HOME AVENUE  
FRESNO, CALIFORNIA 93727  
ATTN: PRODUCT MANAGEMENT**

The buyer shall, together with its notice of claim, offer Netafim USA in writing prompt opportunity to examine the defective product and correct the defect, if possible. This warranty shall be void unless buyer delivers the defective product to Netafim USA at buyer's sole cost and in accordance with Netafim USA's instructions.

# WASTEWATER REUSE AND DRIP DISPERSAL GUIDE

## METRIC CONVERSION FACTORS

Factors for the  
Conversion of U.S.  
Customary Units to  
the International  
System (SI) of Units

### Metric Conversion Units

Multiply the U.S. Customary Unit		By	To Obtain the Corresponding Metric Unit	
Unit	Abbreviation		Unit	Abbreviation
acre	ac	4047	square meter	m <sup>2</sup>
acre	ac	0.4047	hectare	ha
cubic foot	ft <sup>3</sup>	0.2832	cubic meter	m <sup>3</sup>
cubic foot	ft <sup>3</sup>	28.32	liter	l
cubic foot per gallon	ft <sup>3</sup> /gal	7.4805	cubic meters per cubic meter	m <sup>3</sup> /m <sup>3</sup>
cubic foot per minute	ft <sup>3</sup> /min	0.0004719	cubic meters per second	m <sup>3</sup> /s
day	d	86.4	kilosecond	ks
degree Fahrenheit	°F	0.555(F-32)	degree Celsius	°C
foot	ft	0.3048	meter	m
feet per day	ft/d	0.3048	meters per day	m/d
feet per minute	ft/min	0.00508	meters per second	m/s
feet per second	fps	0.3048	meters per second	m/s
gallon	gal	0.003785	cubic meter	m <sup>3</sup>
gallon	gal	3.785	liter	l
gallons per day	GPD	3.785	liters per day	l/d
gallons per day per foot	gal/d/ft	12.419	liters per day per meter	l/d/m
gallons per day per square foot	gal/d/ft <sup>2</sup>	40.746	liters per day per square meter	l/d/m <sup>2</sup>
gallons per hour	GPH	3.785	liters per hour	l/h
gallons per minute	GPM	0.631	liters per second	l/s
horsepower	hp	0.7457	kilowatt	kW
inch	in	2.54	centimeter	cm
inch	in	0.0254	meter	m
inches per day	in/d	2.54	centimeters per day	cm/d
inches per foot	in/ft	8.3333	centimeters per meter	cm/m
inches per hour	in/h	2.54	centimeters per hour	cm/hr
inches per month	in/mo	2.54	centimeters per month	cm/mo
inches per week	in/wk	2.54	centimeters per week	cm/wk
inches per year	in/yr	2.54	centimeters per year	cm/yr
parts per million	ppm	is approximately	milligrams per liter	mg/l
pound	lb	0.4536	kilogram	kg
pounds per acre	lb/ac	0.1122	grams per square meter	g/m <sup>2</sup>
pounds per acre	lb/ac	1.122	kilograms per hectare	kg/ha
pounds per cubic foot	lb/ft <sup>3</sup>	16.019	kilograms per cubic meter	kg/m <sup>3</sup>
pounds per square inch	psi	6.895	kilonewtons per square meter	kN/m <sup>2</sup>
million gallons per day	Mgal/d	0.4381	cubic meter per second	m <sup>3</sup> /s
minutes per inch	MPI	0.3937	minutes per centimeter	min/cm
square foot	ft <sup>2</sup>	0.0929	square meter	m <sup>2</sup>

# WASTEWATER REUSE AND DRIP DISPERSAL GUIDE

**FRICTION LOSS CHARACTERISTICS  
PVC SCHEDULE 40  
IPS PLASTIC PIPE  
(1120, 1220)  
C=150  
Sizes 1/2" to 6"  
Flows 1 to 900 GPM**

*PSI Loss of 100 Feet of Pipe (psi per 100 feet)*

SIZE		1/2"		3/4"		1"		1 1/4"		1 1/2"		2"		2 1/2"		3"		4"		6"	
I.D.		0.622"		0.824"		1.049"		1.380"		1.610"		2.067"		2.469"		3.068"		4.026"		6.065"	
O.D.		0.840"		1.050"		1.315"		1.660"		1.900"		2.375"		2.875"		3.500"		4.500"		6.625"	
Wall Thk		0.109"		0.113"		0.133"		0.140"		0.145"		0.154"		0.203"		0.216"		0.237"		0.280"	
Flow GPM	Flow GPH	Velocity FPS	PSI Loss	Velocity FPS	PSI Loss	Velocity FPS	PSI Loss	Velocity FPS	PSI Loss	Velocity FPS	PSI Loss	Velocity FPS	PSI Loss	Velocity FPS	PSI Loss	Velocity FPS	PSI Loss	Velocity FPS	PSI Loss	Velocity FPS	PSI Loss
1	60	1.06	0.43	0.60	0.11	0.37	0.03	0.21	0.01	0.16	0.00	0.10	0.00	0.07	0.00	0.04	0.00	0.03	0.00	0.01	0.00
2	120	2.11	1.55	1.20	0.39	0.74	0.12	0.43	0.03	0.32	0.02	0.19	0.00	0.13	0.00	0.09	0.00	0.05	0.00	0.02	0.00
3	180	3.17	3.28	1.80	0.84	1.11	0.26	0.64	0.07	0.47	0.03	0.29	0.01	0.20	0.00	0.13	0.00	0.08	0.00	0.03	0.00
4	240	4.22	5.59	2.41	1.42	1.48	0.44	0.86	0.12	0.63	0.05	0.38	0.02	0.27	0.01	0.17	0.00	0.10	0.00	0.04	0.00
5	300	5.28	8.45	3.01	2.15	1.86	0.66	1.07	0.17	0.79	0.08	0.48	0.02	0.34	0.01	0.22	0.00	0.13	0.00	0.06	0.00
6	360	6.34	11.85	3.61	3.02	2.23	0.93	1.29	0.25	0.95	0.12	0.57	0.03	0.40	0.01	0.26	0.01	0.15	0.00	0.07	0.00
7	420	7.39	15.76	4.21	4.01	2.60	1.24	1.50	0.33	1.10	0.15	0.67	0.05	0.47	0.02	0.30	0.01	0.18	0.00	0.08	0.00
8	480	8.45	20.18	4.81	5.14	2.97	1.59	1.72	0.42	1.26	0.20	0.76	0.06	0.54	0.02	0.35	0.01	0.20	0.00	0.09	0.00
9	540	9.50	25.10	5.41	6.39	3.34	1.97	1.93	0.52	1.42	0.25	0.86	0.07	0.60	0.03	0.39	0.01	0.23	0.00	0.10	0.00
10	600	10.56	30.51	6.02	7.77	3.71	2.40	2.15	0.63	1.58	0.30	0.96	0.09	0.67	0.04	0.43	0.01	0.25	0.00	0.11	0.00
11	660	11.61	36.40	6.62	9.26	4.08	2.86	2.36	0.75	1.73	0.36	1.05	0.11	0.74	0.04	0.48	0.02	0.28	0.00	0.12	0.00
12	720	12.67	42.77	7.22	10.88	4.45	3.36	2.57	0.89	1.89	0.42	1.15	0.12	0.80	0.05	0.52	0.02	0.30	0.00	0.13	0.00
14	840			8.42	14.48	5.20	4.47	3.00	1.18	2.21	0.56	1.34	0.16	0.94	0.07	0.61	0.02	0.35	0.01	0.16	0.00
16	960			9.63	18.54	5.94	5.73	3.43	1.51	2.52	0.71	1.53	0.21	1.07	0.09	0.69	0.03	0.40	0.01	0.18	0.00
18	1,080			10.83	23.06	6.68	7.12	3.86	1.88	2.84	0.89	1.72	0.26	1.21	0.11	0.78	0.04	0.45	0.01	0.20	0.00
20	1,200			12.03	28.03	7.42	8.66	4.29	2.28	3.15	1.08	1.91	0.32	1.34	0.13	0.87	0.05	0.50	0.01	0.22	0.00
22	1,320			13.24	33.44	8.17	10.33	4.72	2.72	3.47	1.28	2.10	0.38	1.47	0.16	0.95	0.06	0.55	0.01	0.24	0.00
24	1,440					8.91	12.14	5.15	3.20	3.78	1.51	2.29	0.45	1.61	0.19	1.04	0.07	0.60	0.02	0.27	0.00
26	1,560					9.65	14.08	5.58	3.71	4.10	1.75	2.49	0.52	1.74	0.22	1.13	0.08	0.66	0.02	0.29	0.00
28	1,680					10.39	16.15	6.01	4.25	4.41	2.01	2.68	0.60	1.88	0.25	1.22	0.09	0.71	0.02	0.31	0.00
30	1,800					11.14	18.35	6.44	4.83	4.73	2.28	2.87	0.68	2.01	0.28	1.30	0.10	0.76	0.03	0.33	0.00
35	2,100					12.87	17.44	9.46	8.24	5.74	2.44	4.02	1.03	2.60	0.36	1.51	0.10	0.67	0.01		
40	2,400					13.94	20.23	10.24	9.55	6.21	2.83	4.36	1.19	2.82	0.41	1.64	0.11	0.72	0.02		
45	2,700							9.65	10.24	7.09	4.83	4.30	1.43	3.02	0.60	1.95	0.21	1.13	0.06	0.54	0.01
50	3,000							10.73	12.44	7.88	5.88	4.78	1.74	3.35	0.73	2.17	0.25	1.26	0.07	0.56	0.01
55	3,300							11.80	14.84	8.67	7.01	5.26	2.08	3.69	0.88	2.39	0.30	1.39	0.08	0.61	0.01
60	3,600							12.87	17.44	9.46	8.24	5.74	2.44	4.02	1.03	2.60	0.36	1.51	0.10	0.67	0.01
65	3,900							13.94	20.23	10.24	9.55	6.21	2.83	4.36	1.19	2.82	0.41	1.64	0.11	0.72	0.02
70	4,200							11.03	10.96	6.69	3.25	4.69	1.37	3.04	0.48	1.76	0.13	0.78	0.02		
75	4,500							11.82	12.45	7.17	3.69	5.03	1.55	3.25	0.54	1.89	0.14	0.83	0.02		
80	4,800							12.61	14.03	7.65	4.16	5.36	1.75	3.47	0.61	2.02	0.16	0.89	0.02		
85	5,100							13.40	15.70	8.13	4.65	5.70	1.96	3.69	0.68	2.14	0.18	0.94	0.02		
90	5,400									8.61	5.17	6.03	2.18	3.91	0.76	2.27	0.20	1.00	0.03		
95	5,700									9.08	5.72	6.37	2.41	4.12	0.84	2.39	0.22	1.06	0.03		
100	6,000									9.56	6.29	6.70	2.65	4.34	0.92	2.52	0.25	1.11	0.03		
110	6,600									10.52	7.50	7.37	3.16	4.77	1.10	2.77	0.29	1.22	0.04		
120	7,200									11.47	8.82	8.04	3.71	5.21	1.29	3.02	0.34	1.33	0.05		
130	7,800									12.43	10.22	8.71	4.31	5.64	1.50	3.28	0.40	1.44	0.05		
140	8,400									13.39	11.73	9.38	4.94	6.08	1.72	3.53	0.46	1.55	0.06		
150	9,000													10.05	5.61	6.51	1.95	3.78	0.52	1.67	0.07
160	9,600													10.72	6.33	6.94	2.20	4.03	0.59	1.78	0.08
170	10,200													11.39	7.08	7.38	2.46	4.28	0.66	1.89	0.09
180	10,800													12.06	7.87	7.81	2.73	4.54	0.73	2.00	0.10
190	11,400													12.73	8.70	8.25	3.02	4.79	0.81	2.11	0.11
200	12,000													13.40	9.56	8.68	3.32	5.04	0.89	2.22	0.12
225	13,500															9.76	4.13	5.67	1.10	2.50	0.15
250	15,000															10.85	5.02	6.30	1.34	2.78	0.18
275	16,500															11.93	5.99	6.93	1.60	3.05	0.22
300	18,000															13.02	7.04	7.56	1.88	3.33	0.26
325	19,500																	8.19	2.18	3.61	0.30
350	21,000																	8.82	2.50	3.89	0.34
375	22,500																	9.45	2.84	4.16	0.39
400	24,000																	10.08	3.20	4.44	0.44
425	25,500																	10.71	3.58	4.72	0.49
450	27,000																	11.34	3.98	5.00	0.54
475	28,500																	11.97	4.40	5.28	0.60
500	30,000																	12.60	4.83	5.55	0.66
550	33,000																	13.86	5.77	6.11	0.79
600	36,000																			6.66	0.92
650	39,000																			7.22	1.07
700	42,000																			7.77	1.23
750	45,000																			8.33	1.39
800	48,000																			8.88	1.57
850	51,000																			9.44	1.76
900	54,000																			9.99	1.95

**Note:** Shaded areas of the chart indicate velocities over 5 Ft/Sec. Use with Caution.

Velocities are calculated using the general equation:  
 $V = (0.4085 * (Q / d^2))$

Friction Losses are calculated using the Hazen-Williams Equation:  
 $H_f = 0.2083 * (100 / C)^{1.852} * (Q^{1.852} / d^{4.866})$

V = FPS (feet per second)

H<sub>f</sub> = PSI/100 Ft. (pounds per square inch per 100 feet)

C = 150

Q = GPM (gallons per minute)

d = ID (inside diameter)

# WASTEWATER REUSE AND DRIP DISPERSAL GUIDE

**FRICITION LOSS CHARACTERISTICS  
PVC SCHEDULE 80  
IPS PLASTIC PIPE  
(1120, 1220)  
C=150  
Sizes ½" to 6"  
Flows 1 to 900 GPM**

**PSI Loss of 100 Feet of Pipe (psi per 100 feet)**

SIZE		½"		¾"		1"		1 ¼"		1 ½"		2"		2 ½"		3"		4"		6"	
I.D.		0.546"		0.742"		0.957"		1.278"		1.500"		1.939"		2.323"		2.900"		3.826"		5.761"	
O.D.		0.840"		1.050"		1.315"		1.660"		1.900"		2.375"		2.875"		3.500"		4.500"		6.625"	
Wall Thk		0.147"		0.154"		0.179"		0.191"		0.200"		0.218"		0.276"		0.300"		0.337"		0.432"	
Flow GPM	Flow GPH	Velocity FPS	PSI Loss	Velocity FPS	PSI Loss	Velocity FPS	PSI Loss	Velocity FPS	PSI Loss	Velocity FPS	PSI Loss	Velocity FPS	PSI Loss	Velocity FPS	PSI Loss	Velocity FPS	PSI Loss	Velocity FPS	PSI Loss	Velocity FPS	PSI Loss
1	60	1.37	0.81	0.74	0.18	0.45	0.05	0.25	0.01	0.18	0.01	0.11	0.00	0.08	0.00	0.05	0.00	0.03	0.00	0.01	0.00
2	120	2.74	2.92	1.48	0.66	0.89	0.19	0.50	0.05	0.36	0.02	0.22	0.01	0.15	0.00	0.10	0.00	0.06	0.00	0.02	0.00
3	180	4.11	6.19	2.23	1.39	1.34	0.40	0.75	0.10	0.54	0.05	0.33	0.01	0.23	0.01	0.15	0.00	0.08	0.00	0.04	0.00
4	240	5.48	10.54	2.97	2.37	1.78	0.69	1.00	0.17	0.73	0.08	0.43	0.02	0.30	0.01	0.19	0.00	0.11	0.00	0.05	0.00
5	300	6.85	15.94	3.71	3.58	2.23	1.04	1.25	0.25	0.91	0.12	0.54	0.03	0.38	0.01	0.24	0.00	0.14	0.00	0.06	0.00
6	360	8.22	22.34	4.45	5.02	2.68	1.46	1.50	0.36	1.09	0.16	0.65	0.05	0.45	0.02	0.29	0.01	0.17	0.00	0.07	0.00
7	420	9.59	29.72	5.19	6.68	3.12	1.94	1.75	0.47	1.27	0.22	0.76	0.06	0.53	0.03	0.34	0.01	0.20	0.00	0.09	0.00
8	480	10.96	38.05	5.94	8.55	3.57	2.48	2.00	0.61	1.45	0.28	0.87	0.08	0.61	0.03	0.39	0.01	0.22	0.00	0.10	0.00
9	540	12.33	47.33	6.68	10.64	4.01	3.08	2.25	0.75	1.63	0.35	0.98	0.10	0.68	0.04	0.44	0.01	0.25	0.00	0.11	0.00
10	600	13.70	57.53	7.42	12.93	4.46	3.75	2.50	0.92	1.82	0.42	1.09	0.12	0.76	0.05	0.49	0.02	0.28	0.00	0.12	0.00
11	660			8.16	15.43	4.91	4.47	2.75	1.09	2.00	0.50	1.20	0.14	0.83	0.06	0.53	0.02	0.31	0.01	0.14	0.00
12	720			8.90	18.13	5.35	5.26	3.00	1.29	2.18	0.59	1.30	0.17	0.91	0.07	0.58	0.02	0.33	0.01	0.15	0.00
14	840			10.39	24.12	6.24	6.99	3.50	1.71	2.54	0.78	1.52	0.23	1.06	0.09	0.68	0.03	0.39	0.01	0.17	0.00
16	960			11.87	30.88	7.14	8.95	4.00	2.19	2.90	1.01	1.74	0.29	1.21	0.12	0.78	0.04	0.45	0.01	0.20	0.00
18	1,080			13.36	38.41	8.03	11.14	4.50	2.73	3.27	1.25	1.96	0.36	1.36	0.15	0.87	0.05	0.50	0.01	0.22	0.00
20	1,200					8.92	13.53	5.00	3.31	3.63	1.52	2.17	0.44	1.51	0.18	0.97	0.06	0.56	0.02	0.25	0.00
22	1,320					9.81	16.15	5.50	3.95	3.99	1.81	2.39	0.52	1.67	0.22	1.07	0.07	0.61	0.02	0.27	0.00
24	1,440					10.70	18.97	6.00	4.64	4.36	2.13	2.61	0.61	1.82	0.25	1.17	0.09	0.67	0.02	0.30	0.00
26	1,560					11.60	22.00	6.50	5.39	4.72	2.47	2.82	0.71	1.97	0.29	1.26	0.10	0.73	0.03	0.32	0.00
28	1,680					12.49	25.24	7.00	6.18	5.08	2.83	3.04	0.81	2.12	0.34	1.36	0.11	0.78	0.03	0.34	0.00
30	1,800					13.38	28.68	7.50	7.02	5.45	3.22	3.26	0.92	2.27	0.38	1.46	0.13	0.84	0.03	0.37	0.00
35	2,100							8.75	9.34	6.35	4.28	3.80	1.23	2.65	0.51	1.70	0.17	0.98	0.04	0.43	0.01
40	2,400							10.00	11.96	7.26	5.49	4.35	1.57	3.03	0.65	1.94	0.22	1.12	0.06	0.49	0.01
45	2,700							11.25	14.87	8.17	6.82	4.89	1.96	3.41	0.81	2.19	0.28	1.26	0.07	0.55	0.01
50	3,000							12.51	18.08	9.08	8.29	5.43	2.38	3.78	0.99	2.43	0.34	1.40	0.09	0.62	0.01
55	3,300							13.76	21.57	9.99	9.89	5.98	2.84	4.16	1.18	2.67	0.40	1.53	0.10	0.68	0.01
60	3,600							10.89	11.62	6.52	3.33	4.54	1.38	2.91	0.47	1.67	0.12	0.74	0.02		
65	3,900							11.80	13.48	7.06	3.87	4.92	1.60	3.16	0.55	1.81	0.14	0.80	0.02		
70	4,200							12.71	15.46	7.61	4.43	5.30	1.84	3.40	0.63	1.95	0.16	0.86	0.02		
75	4,500							13.62	17.57	8.15	5.04	5.68	2.09	3.64	0.71	2.09	0.18	0.92	0.03		
80	4,800									8.69	5.68	6.06	2.36	3.89	0.80	2.23	0.21	0.98	0.03		
85	5,100									9.24	6.35	6.43	2.64	4.13	0.90	2.37	0.23	1.05	0.03		
90	5,400									9.78	7.06	6.81	2.93	4.37	1.00	2.51	0.26	1.11	0.04		
95	5,700									10.32	7.81	7.19	3.24	4.61	1.10	2.65	0.29	1.17	0.04		
100	6,000									10.87	8.58	7.57	3.56	4.86	1.21	2.79	0.31	1.23	0.04		
110	6,600									11.95	10.24	8.33	4.25	5.34	1.44	3.07	0.38	1.35	0.05		
120	7,200									13.04	12.03	9.08	4.99	5.83	1.70	3.35	0.44	1.48	0.06		
130	7,800									9.84	5.79	6.31	1.97	3.63	0.51	1.60	0.07				
140	8,400									10.60	6.64	6.80	2.26	3.91	0.59	1.72	0.08				
150	9,000									11.35	7.55	7.29	2.57	4.19	0.67	1.85	0.09				
160	9,600									12.11	8.51	7.77	2.89	4.47	0.75	1.97	0.10				
170	10,200									12.87	9.52	8.26	3.23	4.74	0.84	2.09	0.11				
180	10,800									13.63	10.58	8.74	3.60	5.02	0.93	2.22	0.13				
190	11,400									9.23	3.97	5.30	1.03	2.34	0.14						
200	12,000									9.71	4.37	5.58	1.13	2.46	0.15						
225	13,500									10.93	5.44	6.28	1.41	2.77	0.19						
250	15,000									12.14	6.61	6.98	1.72	3.08	0.23						
275	16,500									13.36	7.88	7.67	2.05	3.38	0.28						
300	18,000															8.37	2.40	3.69	0.33		
325	19,500															9.07	2.79	4.00	0.38		
350	21,000															9.77	3.20	4.31	0.44		
375	22,500															10.46	3.64	4.62	0.50		
400	24,000															11.16	4.10	4.92	0.56		
425	25,500															11.86	4.58	5.23	0.63		
450	27,000															12.56	5.10	5.54	0.70		
475	28,500															13.26	5.63	5.85	0.77		
500	30,000															13.95	6.19	6.15	0.85		
550	33,000																	6.77	1.01		
600	36,000																	7.38	1.18		
650	39,000																	8.00	1.37		
700	42,000																	8.62	1.58		
750	45,000																	9.23	1.79		
800	48,000																	9.85	2.02		
850	51,000																	10.46	2.26		
900	54,000																	11.08	2.51		

**Note:** Shaded areas of the chart indicate velocities over 5 Ft/Sec. Use with Caution.

Velocities are calculated using the general equation:

$$V = (0.4085 * (Q / d^2))$$

Friction Losses are calculated using the Hazen-Williams Equation:

$$H_f = 0.2083 * (100 / C)^{1.852} * (Q^{1.852} / d^{4.866})$$

V = FPS (feet per second)

H<sub>f</sub> = PSI/100 Ft. (pounds per square inch per 100 feet)

C = 150

Q = GPM (gallons per minute)

d = ID (inside diameter)

# WASTEWATER REUSE AND DRIP DISPERSAL GUIDE

**FRICITION LOSS CHARACTERISTICS  
PVC CLASS 315  
IPS PLASTIC PIPE  
(1120, 1220)  
SDR 13.5  
C=150  
Sizes 1/2" to 6"  
Flows 1 to 900 GPM**

**PSI Loss of 100 Feet of Pipe (psi per 100 feet)**

SIZE		1/2"		3/4"		1"		1 1/4"		1 1/2"		2"		2 1/2"		3"		4"		6"	
I.D.		0.716"		0.894"		1.121"		1.414"		1.618"		2.023"		2.449"		2.982"		3.834"		5.643"	
O.D.		0.840"		1.050"		1.315"		1.660"		1.900"		2.375"		2.875"		3.500"		4.500"		6.625"	
Wall Thk		0.062"		0.078"		0.097"		0.123"		0.141"		0.176"		0.213"		0.259"		0.333"		0.491"	
Flow GPM	Flow GPH	Velocity FPS	PSI Loss	Velocity FPS	PSI Loss	Velocity FPS	PSI Loss	Velocity FPS	PSI Loss	Velocity FPS	PSI Loss	Velocity FPS	PSI Loss	Velocity FPS	PSI Loss	Velocity FPS	PSI Loss	Velocity FPS	PSI Loss	Velocity FPS	PSI Loss
1	60	0.80	0.22	0.51	0.07	0.33	0.02	0.20	0.01	0.16	0.00	0.10	0.00	0.07	0.00	0.05	0.00	0.03	0.00	0.01	0.00
2	120	1.59	0.78	1.02	0.27	0.65	0.09	0.41	0.03	0.31	0.01	0.20	0.00	0.14	0.00	0.09	0.00	0.06	0.00	0.03	0.00
3	180	2.39	1.65	1.53	0.56	0.98	0.19	0.61	0.06	0.47	0.03	0.30	0.01	0.20	0.00	0.14	0.00	0.08	0.00	0.04	0.00
4	240	3.19	2.82	2.04	0.96	1.30	0.32	0.82	0.10	0.62	0.05	0.40	0.02	0.27	0.01	0.18	0.00	0.11	0.00	0.05	0.00
5	300	3.98	4.26	2.56	1.45	1.63	0.48	1.02	0.16	0.78	0.08	0.50	0.03	0.34	0.01	0.23	0.00	0.14	0.00	0.06	0.00
6	360	4.78	5.97	3.07	2.03	1.95	0.67	1.23	0.22	0.94	0.11	0.60	0.04	0.41	0.02	0.28	0.01	0.17	0.00	0.08	0.00
7	420	5.58	7.95	3.58	2.70	2.28	0.90	1.43	0.29	1.09	0.15	0.70	0.05	0.48	0.02	0.32	0.01	0.19	0.00	0.09	0.00
8	480	6.37	10.18	4.09	3.45	2.60	1.15	1.63	0.37	1.25	0.19	0.80	0.06	0.54	0.03	0.37	0.01	0.22	0.00	0.10	0.00
9	540	7.17	12.66	4.60	4.30	2.93	1.43	1.84	0.46	1.40	0.24	0.90	0.08	0.61	0.03	0.41	0.01	0.25	0.00	0.12	0.00
10	600	7.97	15.38	5.11	5.22	3.25	1.74	2.04	0.56	1.56	0.29	1.00	0.10	0.68	0.04	0.46	0.01	0.28	0.00	0.13	0.00
11	660	8.77	18.35	5.62	6.23	3.58	2.07	2.25	0.67	1.72	0.35	1.10	0.12	0.75	0.05	0.51	0.02	0.31	0.01	0.14	0.00
12	720	9.56	21.56	6.13	7.32	3.90	2.43	2.45	0.79	1.87	0.41	1.20	0.14	0.82	0.05	0.55	0.02	0.33	0.01	0.15	0.00
14	840	11.16	28.69	7.16	9.74	4.55	3.24	2.86	1.05	2.18	0.54	1.40	0.18	0.95	0.07	0.64	0.03	0.39	0.01	0.18	0.00
16	960	12.75	36.73	8.18	12.47	5.20	4.15	3.27	1.34	2.50	0.70	1.60	0.23	1.09	0.09	0.74	0.04	0.44	0.01	0.21	0.00
18	1,080			9.20	15.51	5.85	5.16	3.68	1.67	2.81	0.86	1.80	0.29	1.23	0.12	0.83	0.04	0.50	0.01	0.23	0.00
20	1,200			10.22	18.85	6.50	6.27	4.09	2.03	3.12	1.05	2.00	0.35	1.36	0.14	0.92	0.05	0.56	0.02	0.26	0.00
22	1,320			11.24	22.49	7.15	7.48	4.49	2.42	3.43	1.25	2.20	0.42	1.50	0.17	1.01	0.06	0.61	0.02	0.28	0.00
24	1,440			12.27	26.42	7.80	8.79	4.90	2.84	3.74	1.47	2.40	0.50	1.63	0.20	1.10	0.08	0.67	0.02	0.31	0.00
26	1,560			13.29	30.65	8.45	10.19	5.31	3.29	4.06	1.71	2.60	0.58	1.77	0.23	1.19	0.09	0.72	0.03	0.33	0.00
28	1,680			9.20	15.51	5.85	5.16	3.68	1.67	2.81	0.86	1.80	0.29	1.23	0.12	0.83	0.04	0.50	0.01	0.23	0.00
30	1,800					9.75	13.28	6.13	4.29	4.68	2.23	2.99	0.75	2.04	0.30	1.38	0.11	0.83	0.03	0.38	0.01
35	2,100					11.38	17.67	7.15	5.71	5.46	2.96	3.49	1.00	2.38	0.39	1.61	0.15	0.97	0.04	0.45	0.01
40	2,400					13.00	22.63	8.17	7.31	6.24	3.79	3.99	1.28	2.72	0.50	1.84	0.19	1.11	0.06	0.51	0.01
45	2,700							9.19	9.09	7.02	4.72	4.49	1.59	3.06	0.63	2.07	0.24	1.25	0.07	0.58	0.01
50	3,000							10.22	11.05	7.80	5.74	4.99	1.93	3.41	0.76	2.30	0.29	1.39	0.09	0.64	0.01
55	3,300							11.24	13.19	8.58	6.84	5.49	2.31	3.75	0.91	2.53	0.35	1.53	0.10	0.71	0.02
60	3,600							12.26	15.49	9.36	8.04	5.99	2.71	4.09	1.07	2.76	0.41	1.67	0.12	0.77	0.02
65	3,900							13.28	17.97	10.14	9.33	6.49	3.14	4.43	1.24	2.99	0.48	1.81	0.14	0.83	0.02
70	4,200									10.92	10.70	6.99	3.61	4.77	1.42	3.22	0.55	1.95	0.16	0.90	0.02
75	4,500									11.70	12.16	7.49	4.10	5.11	1.62	3.45	0.62	2.08	0.18	0.96	0.03
80	4,800									12.48	13.70	7.99	4.62	5.45	1.82	3.68	0.70	2.22	0.21	1.03	0.03
85	5,100									13.26	15.33	8.48	5.17	5.79	2.04	3.90	0.78	2.36	0.23	1.09	0.04
90	5,400											8.98	5.75	6.13	2.27	4.13	0.87	2.50	0.26	1.15	0.04
95	5,700											9.48	6.35	6.47	2.51	4.36	0.96	2.64	0.28	1.22	0.04
100	6,000											9.98	6.98	6.81	2.76	4.59	1.06	2.78	0.31	1.28	0.05
110	6,600											10.98	8.33	7.49	3.29	5.05	1.26	3.06	0.37	1.41	0.06
120	7,200											11.98	9.79	8.17	3.86	5.51	1.48	3.33	0.44	1.54	0.07
130	7,800											12.98	11.35	8.85	4.48	5.97	1.72	3.61	0.51	1.67	0.08
140	8,400											13.97	13.02	9.54	5.14	6.43	1.97	3.89	0.58	1.80	0.09
150	9,000													10.22	5.84	6.89	2.24	4.17	0.66	1.92	0.10
160	9,600													10.90	6.58	7.35	2.52	4.45	0.74	2.05	0.11
170	10,200													11.58	7.36	7.81	2.82	4.72	0.83	2.18	0.13
180	10,800													12.26	8.18	8.27	3.14	5.00	0.92	2.31	0.14
190	11,400													12.94	9.05	8.73	3.47	5.28	1.02	2.44	0.16
200	12,000													13.62	9.95	9.19	3.82	5.56	1.12	2.57	0.17
225	13,500															10.34	4.75	6.25	1.40	2.89	0.21
250	15,000															11.48	5.77	6.95	1.70	3.21	0.26
275	16,500															12.63	6.88	7.64	2.03	3.53	0.31
300	18,000															13.78	8.09	8.34	2.38	3.85	0.36
325	19,500																	9.03	2.76	4.17	0.42
350	21,000																	9.73	3.17	4.49	0.48
375	22,500																	10.42	3.60	4.81	0.55
400	24,000																	11.12	4.06	5.13	0.62
425	25,500																	11.81	4.54	5.45	0.69
450	27,000																	12.51	5.04	5.77	0.77
475	28,500																	13.20	5.57	6.09	0.85
500	30,000																	13.89	6.13	6.41	0.93
550	33,000																			7.06	1.12
600	36,000																			7.70	1.31
650	39,000																			8.34	1.52
700	42,000																			8.98	1.74
750	45,000																			9.62	1.98
800	48,000																			10.26	2.23
850	51,000																			10.90	2.50
900	54,000																			11.55	2.78

**Note:** Shaded areas of the chart indicate velocities over 5 Ft/Sec. Use with Caution.

Velocities are calculated using the general equation:  
 $V = (0.4085 * (Q / d^2))$

Friction Losses are calculated using the Hazen-Williams Equation:  
 $H_f = 0.2083 * (100 / C)^{1.852} * (Q^{1.852} / d^{4.866})$

V = FPS (feet per second)

Hf = PSI/100 Ft. (pounds per square inch per 100 feet)

C = 150

Q = GPM (gallons per minute)

d = ID (inside diameter)

# WASTEWATER REUSE AND DRIP DISPERSAL GUIDE

**FRICITION LOSS CHARACTERISTICS  
PVC CLASS 200  
IPS PLASTIC PIPE  
(1120, 1220)  
SDR 21  
C=150  
Sizes ¾" to 6"  
Flows 1 to 900 GPM**

**PSI Loss of 100 Feet of Pipe (psi per 100 feet)**

SIZE		¾"		1"		1 ¼"		1 ½"		2"		2 ½"		3"		4"		6"	
I.D.		0.930"		1.189"		1.502"		1.720"		2.149"		2.601"		3.166"		4.072"		5.993"	
O.D.		1.050"		1.315"		1.660"		1.900"		2.375"		2.875"		3.500"		4.500"		6.625"	
Wall Thk		0.060"		0.063"		0.079"		0.090"		0.113"		0.137"		0.167"		0.214"		0.316"	
Flow GPM	Flow GPH	Velocity FPS	PSI Loss	Velocity FPS	PSI Loss	Velocity FPS	PSI Loss	Velocity FPS	PSI Loss	Velocity FPS	PSI Loss	Velocity FPS	PSI Loss	Velocity FPS	PSI Loss	Velocity FPS	PSI Loss	Velocity FPS	PSI Loss
1	60	0.47	0.06	0.29	0.02	0.18	0.01	0.14	0.00	0.09	0.00	0.06	0.00	0.04	0.00	0.02	0.00	0.01	0.00
2	120	0.94	0.22	0.58	0.07	0.36	0.02	0.28	0.01	0.18	0.00	0.12	0.00	0.08	0.00	0.05	0.00	0.02	0.00
3	180	1.42	0.46	0.87	0.14	0.54	0.04	0.41	0.02	0.27	0.01	0.18	0.00	0.12	0.00	0.07	0.00	0.03	0.00
4	240	1.89	0.79	1.16	0.24	0.72	0.08	0.55	0.04	0.35	0.01	0.24	0.01	0.16	0.00	0.10	0.00	0.05	0.00
5	300	2.36	1.19	1.44	0.36	0.91	0.12	0.69	0.06	0.44	0.02	0.30	0.01	0.20	0.00	0.12	0.00	0.06	0.00
6	360	2.83	1.67	1.73	0.51	1.09	0.16	0.83	0.08	0.53	0.03	0.36	0.01	0.24	0.00	0.15	0.00	0.07	0.00
7	420	3.31	2.23	2.02	0.67	1.27	0.22	0.97	0.11	0.62	0.04	0.42	0.01	0.29	0.01	0.17	0.00	0.08	0.00
8	480	3.78	2.85	2.31	0.86	1.45	0.28	1.10	0.14	0.71	0.05	0.48	0.02	0.33	0.01	0.20	0.00	0.09	0.00
9	540	4.25	3.55	2.60	1.07	1.63	0.34	1.24	0.18	0.80	0.06	0.54	0.02	0.37	0.01	0.22	0.00	0.10	0.00
10	600	4.72	4.31	2.89	1.30	1.81	0.42	1.38	0.22	0.88	0.07	0.60	0.03	0.41	0.01	0.25	0.00	0.11	0.00
11	660	5.20	5.14	3.18	1.56	1.99	0.50	1.52	0.26	0.97	0.09	0.66	0.03	0.45	0.01	0.27	0.00	0.13	0.00
12	720	5.67	6.04	3.47	1.83	2.17	0.59	1.66	0.30	1.06	0.10	0.72	0.04	0.49	0.02	0.30	0.00	0.14	0.00
14	840	6.61	8.04	4.05	2.43	2.54	0.78	1.93	0.40	1.24	0.14	0.85	0.05	0.57	0.02	0.34	0.01	0.16	0.00
16	960	7.56	10.29	4.62	3.11	2.90	1.00	2.21	0.52	1.42	0.17	0.97	0.07	0.65	0.03	0.39	0.01	0.18	0.00
18	1,080	8.50	12.80	5.20	3.87	3.26	1.24	2.49	0.64	1.59	0.22	1.09	0.09	0.73	0.03	0.44	0.01	0.20	0.00
20	1,200	9.45	15.56	5.78	4.71	3.62	1.51	2.76	0.78	1.77	0.26	1.21	0.10	0.82	0.04	0.49	0.01	0.23	0.00
22	1,320	10.39	18.56	6.36	5.62	3.98	1.80	3.04	0.93	1.95	0.32	1.33	0.12	0.90	0.05	0.54	0.01	0.25	0.00
24	1,440	11.34	21.81	6.93	6.60	4.35	2.12	3.31	1.09	2.12	0.37	1.45	0.15	0.98	0.06	0.59	0.02	0.27	0.00
26	1,560	12.28	25.29	7.51	7.65	4.71	2.45	3.59	1.27	2.30	0.43	1.57	0.17	1.06	0.07	0.64	0.02	0.30	0.00
28	1,680	13.22	29.01	8.09	8.78	5.07	2.82	3.87	1.46	2.48	0.49	1.69	0.19	1.14	0.07	0.69	0.02	0.32	0.00
30	1,800			8.67	9.97	5.43	3.20	4.14	1.65	2.65	0.56	1.81	0.22	1.22	0.08	0.74	0.02	0.34	0.00
35	2,100			10.11	13.27	6.34	4.26	4.83	2.20	3.10	0.74	2.11	0.29	1.43	0.11	0.86	0.03	0.40	0.01
40	2,400			11.56	16.99	7.24	5.45	5.52	2.82	3.54	0.95	2.42	0.38	1.63	0.14	0.99	0.04	0.45	0.01
45	2,700			13.00	21.13	8.15	6.78	6.21	3.51	3.98	1.19	2.72	0.47	1.83	0.18	1.11	0.05	0.51	0.01
50	3,000					9.05	8.24	6.90	4.26	4.42	1.44	3.02	0.57	2.04	0.22	1.23	0.06	0.57	0.01
55	3,300					9.96	9.83	7.59	5.08	4.86	1.72	3.32	0.68	2.24	0.26	1.35	0.08	0.63	0.01
60	3,600					10.86	11.55	8.28	5.97	5.31	2.02	3.62	0.80	2.45	0.31	1.48	0.09	0.68	0.01
65	3,900					11.77	13.39	8.98	6.93	5.75	2.34	3.92	0.93	2.65	0.36	1.60	0.10	0.74	0.02
70	4,200					12.68	15.36	9.67	7.95	6.19	2.69	4.23	1.06	2.85	0.41	1.72	0.12	0.80	0.02
75	4,500					13.58	17.46	10.36	9.03	6.63	3.05	4.53	1.21	3.06	0.46	1.85	0.14	0.85	0.02
80	4,800							11.05	10.17	7.08	3.44	4.83	1.36	3.26	0.52	1.97	0.15	0.91	0.02
85	5,100							11.74	11.38	7.52	3.85	5.13	1.52	3.46	0.58	2.09	0.17	0.97	0.03
90	5,400							12.43	12.65	7.96	4.28	5.43	1.69	3.67	0.65	2.22	0.19	1.02	0.03
95	5,700							13.12	13.99	8.40	4.73	5.74	1.87	3.87	0.72	2.34	0.21	1.08	0.03
100	6,000							13.81	15.38	8.85	5.20	6.04	2.06	4.08	0.79	2.46	0.23	1.14	0.04
110	6,600									9.73	6.21	6.64	2.45	4.48	0.94	2.71	0.28	1.25	0.04
120	7,200									10.61	7.30	7.25	2.88	4.89	1.11	2.96	0.33	1.36	0.05
130	7,800									11.50	8.46	7.85	3.34	5.30	1.28	3.20	0.38	1.48	0.06
140	8,400									12.38	9.71	8.45	3.83	5.71	1.47	3.45	0.43	1.59	0.07
150	9,000									13.27	11.03	9.06	4.36	6.11	1.67	3.70	0.49	1.71	0.08
160	9,600											9.66	4.91	6.52	1.89	3.94	0.55	1.82	0.08
170	10,200											10.27	5.49	6.93	2.11	4.19	0.62	1.93	0.09
180	10,800											10.87	6.11	7.34	2.35	4.43	0.69	2.05	0.11
190	11,400											11.47	6.75	7.74	2.59	4.68	0.76	2.16	0.12
200	12,000											12.08	7.42	8.15	2.85	4.93	0.84	2.27	0.13
225	13,500											13.59	9.23	9.17	3.55	5.54	1.04	2.56	0.16
250	15,000													10.19	4.31	6.16	1.27	2.84	0.19
275	16,500													11.21	5.14	6.77	1.51	3.13	0.23
300	18,000													12.23	6.04	7.39	1.78	3.41	0.27
325	19,500													13.25	7.01	8.01	2.06	3.70	0.31
350	21,000															8.62	2.36	3.98	0.36
375	22,500															9.24	2.68	4.27	0.41
400	24,000															9.85	3.03	4.55	0.46
425	25,500															10.47	3.38	4.83	0.52
450	27,000															11.09	3.76	5.12	0.57
475	28,500															11.70	4.16	5.40	0.63
500	30,000															12.32	4.57	5.69	0.70
550	33,000															13.55	5.46	6.26	0.83
600	36,000																	6.82	0.98
650	39,000																	7.39	1.13
700	42,000																	7.96	1.30
750	45,000																	8.53	1.48
800	48,000																	9.10	1.67
850	51,000																	9.67	1.86
900	54,000																	10.24	2.07

**Note:** Shaded areas of the chart indicate velocities over 5 Ft/Sec. Use with Caution.

Velocities are calculated using the general equation:

$$V = (0.4085 * (Q / d^2))$$

Friction Losses are calculated using the Hazen-Williams Equation:

$$H_f = 0.2083 * (100 / C)^{1.852} * (Q^{1.852} / d^{4.866})$$

V = FPS (feet per second)

H<sub>f</sub> = PSI/100 Ft. (pounds per square inch per 100 feet)

C = 150

Q = GPM (gallons per minute)

d = ID (inside diameter)



# WASTEWATER REUSE AND DRIP DISPERSAL GUIDE

**FRICITION LOSS CHARACTERISTICS  
PVC CLASS 160  
IPS PLASTIC PIPE  
(1120, 1220)  
SDR 26  
C=150  
Sizes 1" to 6"  
Flows 1 to 600 GPM**

**PSI Loss of 100 Feet of Pipe (psi per 100 feet)**

Flow GPM	Flow GPH	1"		1 1/4"		1 1/2"		2"		2 1/2"		3"		4"		6"	
		Velocity FPS	PSI Loss	Velocity FPS	PSI Loss	Velocity FPS	PSI Loss	Velocity FPS	PSI Loss	Velocity FPS	PSI Loss	Velocity FPS	PSI Loss	Velocity FPS	PSI Loss	Velocity FPS	PSI Loss
1	60	0.29	0.02	0.17	0.01	0.13	0.00	0.08	0.00	0.06	0.00	0.04	0.00	0.02	0.00	0.01	0.00
2	120	0.57	0.06	0.35	0.02	0.27	0.01	0.17	0.00	0.12	0.00	0.08	0.00	0.05	0.00	0.02	0.00
3	180	0.86	0.14	0.52	0.04	0.40	0.02	0.25	0.01	0.17	0.00	0.12	0.00	0.07	0.00	0.03	0.00
4	240	1.14	0.23	0.70	0.07	0.53	0.04	0.34	0.01	0.23	0.00	0.16	0.00	0.09	0.00	0.04	0.00
5	300	1.43	0.35	0.87	0.11	0.66	0.05	0.42	0.02	0.29	0.01	0.20	0.00	0.12	0.00	0.05	0.00
6	360	1.72	0.49	1.04	0.15	0.80	0.08	0.51	0.03	0.35	0.01	0.23	0.00	0.14	0.00	0.07	0.00
7	420	2.00	0.66	1.22	0.20	0.93	0.10	0.59	0.03	0.41	0.01	0.27	0.01	0.17	0.00	0.08	0.00
8	480	2.29	0.84	1.39	0.25	1.06	0.13	0.68	0.04	0.46	0.02	0.31	0.01	0.19	0.00	0.09	0.00
9	540	2.57	1.05	1.57	0.31	1.20	0.16	0.76	0.05	0.52	0.02	0.35	0.01	0.21	0.00	0.10	0.00
10	600	2.86	1.27	1.74	0.38	1.33	0.20	0.85	0.07	0.58	0.03	0.39	0.01	0.24	0.00	0.11	0.00
11	660	3.15	1.52	1.91	0.45	1.46	0.23	0.93	0.08	0.64	0.03	0.43	0.01	0.26	0.00	0.12	0.00
12	720	3.43	1.78	2.09	0.53	1.59	0.28	1.02	0.09	0.70	0.04	0.47	0.01	0.28	0.00	0.13	0.00
14	840	4.00	2.37	2.44	0.71	1.86	0.37	1.19	0.12	0.81	0.05	0.55	0.02	0.33	0.01	0.15	0.00
16	960	4.58	3.04	2.78	0.91	2.12	0.47	1.36	0.16	0.93	0.06	0.63	0.02	0.38	0.01	0.17	0.00
18	1,080	5.15	3.78	3.13	1.13	2.39	0.58	1.53	0.20	1.04	0.08	0.70	0.03	0.43	0.01	0.20	0.00
20	1,200	5.72	4.59	3.48	1.37	2.66	0.71	1.70	0.24	1.16	0.09	0.78	0.04	0.47	0.01	0.22	0.00
22	1,320	6.29	5.48	3.83	1.64	2.92	0.85	1.87	0.29	1.27	0.11	0.86	0.04	0.52	0.01	0.24	0.00
24	1,440	6.87	6.44	4.18	1.92	3.19	0.99	2.04	0.34	1.39	0.13	0.94	0.05	0.57	0.01	0.26	0.00
26	1,560	7.44	7.47	4.53	2.23	3.45	1.15	2.21	0.39	1.51	0.15	1.02	0.06	0.62	0.02	0.28	0.00
28	1,680	8.01	8.56	4.87	2.56	3.72	1.32	2.38	0.45	1.62	0.18	1.10	0.07	0.66	0.02	0.31	0.00
30	1,800	8.58	9.73	5.22	2.91	3.98	1.50	2.55	0.51	1.74	0.20	1.17	0.08	0.71	0.02	0.33	0.00
35	2,100	10.01	12.95	6.09	3.87	4.65	2.00	2.97	0.67	2.03	0.27	1.37	0.10	0.83	0.03	0.38	0.00
40	2,400	11.44	16.58	6.96	4.95	5.31	2.56	3.40	0.86	2.32	0.34	1.57	0.13	0.95	0.04	0.44	0.01
45	2,700	12.87	20.62	7.83	6.16	5.98	3.19	3.82	1.07	2.61	0.42	1.76	0.16	1.07	0.05	0.49	0.01
50	3,000			8.70	7.48	6.64	3.87	4.25	1.31	2.90	0.52	1.96	0.20	1.18	0.06	0.55	0.01
55	3,300			9.57	8.93	7.30	4.62	4.67	1.56	3.19	0.61	2.15	0.24	1.30	0.07	0.60	0.01
60	3,600			10.44	10.49	7.97	5.43	5.10	1.83	3.48	0.72	2.35	0.28	1.42	0.08	0.66	0.01
65	3,900			11.31	12.16	8.63	6.30	5.52	2.12	3.77	0.84	2.55	0.32	1.54	0.09	0.71	0.01
70	4,200			12.18	13.95	9.29	7.22	5.95	2.44	4.06	0.96	2.74	0.37	1.66	0.11	0.76	0.02
75	4,500			13.05	15.86	9.96	8.21	6.37	2.77	4.35	1.09	2.94	0.42	1.78	0.12	0.82	0.02
80	4,800			13.92	17.87	10.62	9.25	6.80	3.12	4.64	1.23	3.13	0.47	1.89	0.14	0.87	0.02
85	5,100					11.29	10.35	7.22	3.49	4.93	1.38	3.33	0.53	2.01	0.16	0.93	0.02
90	5,400					11.95	11.50	7.64	3.88	5.22	1.53	3.52	0.59	2.13	0.17	0.98	0.03
95	5,700					12.61	12.72	8.07	4.29	5.51	1.69	3.72	0.65	2.25	0.19	1.04	0.03
100	6,000					13.28	13.98	8.49	4.72	5.80	1.86	3.92	0.72	2.37	0.21	1.09	0.03
110	6,600							9.34	5.63	6.37	2.22	4.31	0.85	2.60	0.25	1.20	0.04
120	7,200							10.19	6.61	6.95	2.61	4.70	1.00	2.84	0.30	1.31	0.04
130	7,800							11.04	7.67	7.53	3.02	5.09	1.16	3.08	0.34	1.42	0.05
140	8,400							11.89	8.79	8.11	3.47	5.48	1.34	3.31	0.39	1.53	0.06
150	9,000							12.74	9.99	8.69	3.94	5.87	1.52	3.55	0.45	1.64	0.07
160	9,600							13.59	11.26	9.27	4.44	6.26	1.71	3.79	0.50	1.75	0.08
170	10,200									9.85	4.97	6.66	1.91	4.02	0.56	1.86	0.09
180	10,800									10.43	5.52	7.05	2.13	4.26	0.63	1.97	0.10
190	11,400									11.01	6.11	7.44	2.35	4.50	0.69	2.08	0.11
200	12,000									11.59	6.72	7.83	2.59	4.73	0.76	2.18	0.12
225	13,500									13.04	8.35	8.81	3.22	5.33	0.95	2.46	0.14
250	15,000											9.79	3.91	5.92	1.15	2.73	0.18
275	16,500											10.77	4.67	6.51	1.37	3.00	0.21
300	18,000											11.75	5.48	7.10	1.61	3.28	0.25
325	19,500											12.73	6.36	7.69	1.87	3.55	0.28
350	21,000											13.70	7.29	8.29	2.14	3.82	0.33
375	22,500													8.88	2.44	4.10	0.37
400	24,000													9.47	2.75	4.37	0.42
425	25,500													10.06	3.07	4.64	0.47
450	27,000													10.65	3.41	4.92	0.52
475	28,500													11.24	3.77	5.19	0.58
500	30,000													11.84	4.15	5.46	0.63
550	33,000													13.02	4.95	6.01	0.75
600	36,000															6.55	0.89
650	39,000															7.10	1.03
700	42,000															7.65	1.18
750	45,000															8.19	1.34
800	48,000															8.74	1.51
850	51,000															9.29	1.69
900	54,000															9.83	1.88

**Note:** Shaded areas of the chart indicate velocities over 5 Ft/Sec. Use with Caution.

Velocities are calculated using the general equation:

$$V = (0.4085 * (Q / d^2))$$

Friction Losses are calculated using the Hazen-Williams Equation:

$$H_f = 0.2083 * (100 / C)^{1.852} * (Q^{1.852} / d^{4.866})$$

V = FPS (feet per second)

Hf = PSI/100 Ft. (pounds per square inch per 100 feet)

C = 150

Q = GPM (gallons per minute)

d = ID (inside diameter)

# WASTEWATER REUSE AND DRIP DISPERSAL GUIDE

**FRICITION LOSS CHARACTERISTICS  
PVC CLASS 125  
IPS PLASTIC PIPE  
(1120, 1220)  
SDR 32.5  
C=150  
Sizes 1" to 6"  
Flows 1 to 600 GPM**

**PSI Loss of 100 Feet of Pipe (psi per 100 feet)**

Flow GPM	Flow GPH	1"		1 1/4"		1 1/2"		2"		2 1/2"		3"		4"		6"	
		Velocity FPS	PSI Loss	Velocity FPS	PSI Loss	Velocity FPS	PSI Loss	Velocity FPS	PSI Loss	Velocity FPS	PSI Loss	Velocity FPS	PSI Loss	Velocity FPS	PSI Loss	Velocity FPS	PSI Loss
1	60	0.28	0.02	0.17	0.01	0.13	0.00	0.08	0.00	0.06	0.00	0.04	0.00	0.02	0.00	0.01	0.00
2	120	0.56	0.06	0.34	0.02	0.26	0.01	0.16	0.00	0.11	0.00	0.08	0.00	0.05	0.00	0.02	0.00
3	180	0.84	0.13	0.51	0.04	0.39	0.02	0.25	0.01	0.17	0.00	0.11	0.00	0.07	0.00	0.03	0.00
4	240	1.11	0.22	0.68	0.07	0.51	0.03	0.33	0.01	0.22	0.00	0.15	0.00	0.09	0.00	0.04	0.00
5	300	1.39	0.33	0.85	0.10	0.64	0.05	0.41	0.02	0.28	0.01	0.19	0.00	0.11	0.00	0.05	0.00
6	360	1.67	0.46	1.02	0.14	0.77	0.07	0.49	0.02	0.34	0.01	0.23	0.00	0.14	0.00	0.06	0.00
7	420	1.95	0.62	1.19	0.19	0.90	0.09	0.58	0.03	0.39	0.01	0.27	0.00	0.16	0.00	0.07	0.00
8	480	2.23	0.79	1.36	0.24	1.03	0.12	0.66	0.04	0.45	0.02	0.30	0.01	0.18	0.00	0.08	0.00
9	540	2.51	0.98	1.53	0.30	1.16	0.15	0.74	0.05	0.50	0.02	0.34	0.01	0.21	0.00	0.10	0.00
10	600	2.79	1.19	1.70	0.36	1.28	0.18	0.82	0.06	0.56	0.02	0.38	0.01	0.23	0.00	0.11	0.00
11	660	3.06	1.42	1.88	0.43	1.41	0.22	0.90	0.07	0.62	0.03	0.42	0.01	0.25	0.00	0.12	0.00
12	720	3.34	1.67	2.05	0.51	1.54	0.25	0.99	0.09	0.67	0.03	0.45	0.01	0.27	0.00	0.13	0.00
14	840	3.90	2.22	2.39	0.67	1.80	0.34	1.15	0.11	0.79	0.05	0.53	0.02	0.32	0.01	0.15	0.00
16	960	4.46	2.85	2.73	0.86	2.05	0.43	1.32	0.15	0.90	0.06	0.61	0.02	0.37	0.01	0.17	0.00
18	1,080	5.01	3.54	3.07	1.07	2.31	0.54	1.48	0.18	1.01	0.07	0.68	0.03	0.41	0.01	0.19	0.00
20	1,200	5.57	4.31	3.41	1.30	2.57	0.65	1.64	0.22	1.12	0.09	0.76	0.03	0.46	0.01	0.21	0.00
22	1,320	6.13	5.14	3.75	1.56	2.82	0.78	1.81	0.26	1.23	0.10	0.83	0.04	0.50	0.01	0.23	0.00
24	1,440	6.69	6.03	4.09	1.83	3.08	0.92	1.97	0.31	1.35	0.12	0.91	0.05	0.55	0.01	0.25	0.00
26	1,560	7.24	7.00	4.43	2.12	3.34	1.06	2.14	0.36	1.46	0.14	0.98	0.05	0.60	0.02	0.27	0.00
28	1,680	7.80	8.03	4.77	2.43	3.59	1.22	2.30	0.41	1.57	0.16	1.06	0.06	0.64	0.02	0.30	0.00
30	1,800	8.36	9.12	5.11	2.76	3.85	1.38	2.47	0.47	1.68	0.18	1.14	0.07	0.69	0.02	0.32	0.00
35	2,100	9.75	12.14	5.97	3.67	4.49	1.84	2.88	0.62	1.96	0.25	1.33	0.09	0.80	0.03	0.37	0.00
40	2,400	11.14	15.54	6.82	4.71	5.13	2.36	3.29	0.80	2.24	0.31	1.52	0.12	0.92	0.04	0.42	0.01
45	2,700	12.53	19.33	7.67	5.85	5.78	2.93	3.70	0.99	2.52	0.39	1.70	0.15	1.03	0.04	0.48	0.01
50	3,000	13.93	23.49	8.52	7.11	6.42	3.57	4.11	1.21	2.80	0.48	1.89	0.18	1.14	0.05	0.53	0.01
55	3,300			9.38	8.49	7.06	4.26	4.52	1.44	3.08	0.57	2.08	0.22	1.26	0.06	0.58	0.01
60	3,600			10.23	9.97	7.70	5.00	4.93	1.69	3.36	0.67	2.27	0.26	1.37	0.08	0.63	0.01
65	3,900			11.08	11.57	8.34	5.80	5.34	1.96	3.65	0.77	2.46	0.30	1.49	0.09	0.69	0.01
70	4,200			11.93	13.27	8.98	6.65	5.76	2.25	3.93	0.89	2.65	0.34	1.60	0.10	0.74	0.02
75	4,500			12.79	15.07	9.63	7.56	6.17	2.56	4.21	1.01	2.84	0.39	1.72	0.11	0.79	0.02
80	4,800			13.64	16.99	10.27	8.52	6.58	2.88	4.49	1.14	3.03	0.44	1.83	0.13	0.85	0.02
85	5,100					10.91	9.53	6.99	3.22	4.77	1.27	3.22	0.49	1.95	0.14	0.90	0.02
90	5,400					11.55	10.59	7.40	3.58	5.05	1.41	3.41	0.54	2.06	0.16	0.95	0.02
95	5,700					12.19	11.71	7.81	3.96	5.33	1.56	3.60	0.60	2.18	0.18	1.00	0.03
100	6,000					12.84	12.88	8.22	4.36	5.61	1.72	3.79	0.66	2.29	0.19	1.06	0.03
110	6,600							9.04	5.20	6.17	2.05	4.17	0.79	2.52	0.23	1.16	0.04
120	7,200							9.87	6.11	6.73	2.41	4.55	0.93	2.75	0.27	1.27	0.04
130	7,800							10.69	7.08	7.29	2.79	4.92	1.07	2.98	0.32	1.37	0.05
140	8,400							11.51	8.12	7.85	3.20	5.30	1.23	3.21	0.36	1.48	0.06
150	9,000							12.33	9.23	8.41	3.64	5.68	1.40	3.43	0.41	1.59	0.06
160	9,600							13.16	10.40	8.97	4.10	6.06	1.58	3.66	0.46	1.69	0.07
170	10,200							13.98	11.64	9.53	4.59	6.44	1.77	3.89	0.52	1.80	0.08
180	10,800									10.09	5.10	6.82	1.96	4.12	0.58	1.90	0.09
190	11,400									10.65	5.64	7.20	2.17	4.35	0.64	2.01	0.10
200	12,000									11.22	6.20	7.58	2.39	4.58	0.70	2.11	0.11
225	13,500									12.62	7.71	8.52	2.97	5.15	0.87	2.38	0.13
250	15,000											9.47	3.61	5.72	1.06	2.64	0.16
275	16,500											10.42	4.30	6.30	1.26	2.91	0.19
300	18,000											11.36	5.06	6.87	1.49	3.17	0.23
325	19,500											12.31	5.86	7.44	1.72	3.43	0.26
350	21,000											13.26	6.73	8.01	1.98	3.70	0.30
375	22,500													8.59	2.25	3.96	0.34
400	24,000													9.16	2.53	4.23	0.39
425	25,500													9.73	2.83	4.49	0.43
450	27,000													10.30	3.15	4.76	0.48
475	28,500													10.88	3.48	5.02	0.53
500	30,000													11.45	3.83	5.28	0.58
550	33,000													12.59	4.56	5.81	0.70
600	36,000													13.74	5.36	6.34	0.82
650	39,000															6.87	0.95
700	42,000															7.40	1.09
750	45,000															7.93	1.24
800	48,000															8.46	1.39
850	51,000															8.98	1.56
900	54,000															9.51	1.73

**Note:** Shaded areas of the chart indicate velocities over 5 Ft/Sec. Use with Caution.

Velocities are calculated using the general equation:

$$V = (0.4085 * (Q / d^2))$$

Friction Losses are calculated using the Hazen-Williams Equation:

$$H_f = 0.2083 * (100 / C)^{1.852} * (Q^{1.852} / d^{4.866})$$

V = FPS (feet per second)

H<sub>f</sub> = PSI/100 Ft. (pounds per square inch per 100 feet)

C = 150

Q = GPM (gallons per minute)

d = ID (inside diameter)

# WASTEWATER REUSE AND DRIP DISPERSAL GUIDE

**FRICITION LOSS CHARACTERISTICS POLYETHYLENE (PE) SDR PRESSURE RATED PIPE**  
 (2306, 3206, 3306)  
 SDR 7, 9, 11.5, 15  
 C=150  
 Sizes ½" to 6"  
 Flows 1 to 900 GPM

**PSI Loss of 100 Feet of Pipe (psi per 100 feet)**

SIZE I.D.		½" 0.622"		¾" 0.824"		1" 1.049"		1 ¼" 1.380"		1 ½" 1.610"		2" 2.067"		2 ½" 2.469"		3" 3.068"		4" 4.026"		6" 6.065"	
Flow GPM	Flow GPH	Velocity FPS	PSI Loss	Velocity FPS	PSI Loss	Velocity FPS	PSI Loss	Velocity FPS	PSI Loss	Velocity FPS	PSI Loss	Velocity FPS	PSI Loss	Velocity FPS	PSI Loss	Velocity FPS	PSI Loss	Velocity FPS	PSI Loss	Velocity FPS	PSI Loss
1	60	1.06	0.49	0.60	0.12	0.37	0.04	0.21	0.01	0.16	0.00	0.10	0.00	0.07	0.00	0.04	0.00	0.03	0.00	0.01	0.00
2	120	2.11	1.76	1.20	0.45	0.74	0.14	0.43	0.04	0.32	0.02	0.19	0.01	0.13	0.00	0.09	0.00	0.05	0.00	0.02	0.00
3	180	3.17	3.73	1.80	0.95	1.11	0.29	0.64	0.08	0.47	0.04	0.29	0.01	0.20	0.00	0.13	0.00	0.08	0.00	0.03	0.00
4	240	4.22	6.35	2.41	1.62	1.48	0.50	0.86	0.13	0.63	0.06	0.38	0.02	0.27	0.01	0.17	0.00	0.10	0.00	0.04	0.00
5	300	5.28	9.60	3.01	2.44	1.86	0.76	1.07	0.20	0.79	0.09	0.48	0.03	0.34	0.01	0.22	0.00	0.13	0.00	0.06	0.00
6	360	6.34	13.46	3.61	3.43	2.23	1.06	1.29	0.28	0.95	0.13	0.57	0.04	0.40	0.02	0.26	0.01	0.15	0.00	0.07	0.00
7	420	7.39	17.91	4.21	4.56	2.60	1.41	1.50	0.37	1.10	0.18	0.67	0.05	0.47	0.02	0.30	0.01	0.18	0.00	0.08	0.00
8	480	8.45	22.93	4.81	5.84	2.97	1.80	1.72	0.47	1.26	0.22	0.76	0.07	0.54	0.03	0.35	0.01	0.20	0.00	0.09	0.00
9	540	9.50	28.52	5.41	7.26	3.34	2.24	1.93	0.59	1.42	0.28	0.86	0.08	0.60	0.03	0.39	0.01	0.23	0.00	0.10	0.00
10	600	10.56	34.67	6.02	8.82	3.71	2.73	2.15	0.72	1.58	0.34	0.96	0.10	0.67	0.04	0.43	0.01	0.25	0.00	0.11	0.00
11	660	11.61	41.36	6.62	10.53	4.08	3.25	2.36	0.86	1.73	0.40	1.05	0.12	0.74	0.05	0.48	0.02	0.28	0.00	0.12	0.00
12	720	12.67	48.60	7.22	12.37	4.45	3.82	2.57	1.01	1.89	0.48	1.15	0.14	0.80	0.06	0.52	0.02	0.30	0.01	0.13	0.00
14	840			8.42	16.45	5.20	5.08	3.00	1.34	2.21	0.63	1.34	0.19	0.94	0.08	0.61	0.03	0.35	0.01	0.16	0.00
16	960			9.63	21.07	5.94	6.51	3.43	1.71	2.52	0.81	1.53	0.24	1.07	0.10	0.69	0.04	0.40	0.01	0.18	0.00
18	1,080			10.83	26.21	6.68	8.10	3.86	2.13	2.84	1.01	1.72	0.30	1.21	0.13	0.78	0.04	0.45	0.01	0.20	0.00
20	1,200			12.03	31.85	7.42	9.84	4.29	2.59	3.15	1.22	1.91	0.36	1.34	0.15	0.87	0.05	0.50	0.01	0.22	0.00
22	1,320			13.24	38.00	8.17	11.74	4.72	3.09	3.47	1.46	2.10	0.43	1.47	0.18	0.95	0.06	0.55	0.02	0.24	0.00
24	1,440					8.91	13.79	5.15	3.63	3.78	1.72	2.29	0.51	1.61	0.21	1.04	0.07	0.60	0.02	0.27	0.00
26	1,560					9.65	16.00	5.58	4.21	4.10	1.99	2.49	0.59	1.74	0.25	1.13	0.09	0.66	0.02	0.29	0.00
28	1,680					10.39	18.35	6.01	4.83	4.41	2.28	2.68	0.68	1.88	0.28	1.22	0.10	0.71	0.03	0.31	0.00
30	1,800					11.14	20.85	6.44	5.49	4.73	2.59	2.87	0.77	2.01	0.32	1.30	0.11	0.76	0.03	0.33	0.00
35	2,100					12.99	27.74	7.51	7.30	5.52	3.45	3.35	1.02	2.35	0.43	1.52	0.15	0.88	0.04	0.39	0.01
40	2,400							8.58	9.35	6.30	4.42	3.82	1.31	2.68	0.55	1.74	0.19	1.01	0.05	0.44	0.01
45	2,700							9.65	11.63	7.09	5.49	4.30	1.63	3.02	0.69	1.95	0.24	1.13	0.06	0.50	0.01
50	3,000							10.73	14.14	7.88	6.68	4.78	1.98	3.35	0.83	2.17	0.29	1.26	0.08	0.56	0.01
55	3,300							11.80	16.87	8.67	7.97	5.26	2.36	3.69	0.99	2.39	0.35	1.39	0.09	0.61	0.01
60	3,600							12.87	19.82	9.46	9.36	5.74	2.77	4.02	1.17	2.60	0.41	1.51	0.11	0.67	0.01
65	3,900							13.94	22.98	10.24	10.86	6.21	3.22	4.36	1.36	2.82	0.47	1.64	0.13	0.72	0.02
70	4,200									11.03	12.45	6.69	3.69	4.69	1.55	3.04	0.54	1.76	0.14	0.78	0.02
75	4,500									11.82	14.15	7.17	4.19	5.03	1.77	3.25	0.61	1.89	0.16	0.83	0.02
80	4,800									12.61	15.95	7.65	4.73	5.36	1.99	3.47	0.69	2.02	0.18	0.89	0.03
85	5,100									13.40	17.84	8.13	5.29	5.70	2.23	3.69	0.77	2.14	0.21	0.94	0.03
90	5,400											8.61	5.88	6.03	2.48	3.91	0.86	2.27	0.23	1.00	0.03
95	5,700											9.08	6.50	6.37	2.74	4.12	0.95	2.39	0.25	1.06	0.03
100	6,000											9.56	7.15	6.70	3.01	4.34	1.05	2.52	0.28	1.11	0.04
110	6,600											10.52	8.53	7.37	3.59	4.77	1.25	2.77	0.33	1.22	0.05
120	7,200											11.47	10.02	8.04	4.22	5.21	1.47	3.02	0.39	1.33	0.05
130	7,800											12.43	11.62	8.71	4.89	5.64	1.70	3.28	0.45	1.44	0.06
140	8,400											13.39	13.33	9.38	5.61	6.08	1.95	3.53	0.52	1.55	0.07
150	9,000													10.05	6.38	6.51	2.22	3.78	0.59	1.67	0.08
160	9,600													10.72	7.19	6.94	2.50	4.03	0.67	1.78	0.09
170	10,200													11.39	8.04	7.38	2.79	4.28	0.74	1.89	0.10
180	10,800													12.06	8.94	7.81	3.11	4.54	0.83	2.00	0.11
190	11,400													12.73	9.88	8.25	3.43	4.79	0.92	2.11	0.12
200	12,000													13.40	10.87	8.68	3.78	5.04	1.01	2.22	0.14
225	13,500															9.76	4.70	5.67	1.25	2.50	0.17
250	15,000															10.85	5.71	6.30	1.52	2.78	0.21
275	16,500															11.93	6.81	6.93	1.81	3.05	0.25
300	18,000															13.02	8.00	7.56	2.13	3.33	0.29
325	19,500																	8.19	2.47	3.61	0.34
350	21,000																	8.82	2.84	3.89	0.39
375	22,500																	9.45	3.22	4.16	0.44
400	24,000																	10.08	3.63	4.44	0.49
425	25,500																	10.71	4.06	4.72	0.55
450	27,000																	11.34	4.52	5.00	0.62
475	28,500																	11.97	4.99	5.28	0.68
500	30,000																	12.60	5.49	5.55	0.75
550	33,000																	13.86	6.55	6.11	0.89
600	36,000																			6.66	1.05
650	39,000																			7.22	1.22
700	42,000																			7.77	1.39
750	45,000																			8.33	1.58
800	48,000																			8.88	1.79
850	51,000																			9.44	2.00
900	54,000																			9.99	2.22

**Note:** Shaded areas of the chart indicate velocities over 5 Ft/Sec. Use with Caution.

Velocities are calculated using the general equation:  
 $V = (0.4085 * (Q / d^2))$

Friction Losses are calculated using the Hazen-Williams Equation:  
 $H_f = 0.2083 * (100 / C)^{1.852} * (Q^{1.852} / d^{4.866})$

V = FPS (feet per second)

H<sub>f</sub> = PSI/100 Ft. (pounds per square inch per 100 feet)

C = 150

Q = GPM (gallons per minute)

d = ID (inside diameter)

# WASTEWATER REUSE AND DRIP DISPERSAL GUIDE

**FRICITION LOSS CHARACTERISTICS SCHEDULE 40 STANDARD STEEL**  
*C=100*  
 Sizes ½" to 6"  
 Flows 1 to 900 GPM

**PSI Loss of 100 Feet of Pipe (psi per 100 feet)**

SIZE		½"		¾"		1"		1 ¼"		1 ½"		2"		2 ½"		3"		4"		6"	
I.D.		0.622"		0.824"		1.049"		1.380"		1.610"		2.067"		2.469"		3.068"		4.026"		6.065"	
O.D.		0.840"		1.050"		1.315"		1.660"		1.900"		2.375"		2.875"		3.500"		4.500"		6.625"	
Wall Thk		0.109"		0.113"		0.133"		0.140"		0.145"		0.154"		0.203"		0.216"		0.237"		0.280"	
Flow GPM	Flow GPH	Velocity FPS	PSI Loss	Velocity FPS	PSI Loss	Velocity FPS	PSI Loss	Velocity FPS	PSI Loss	Velocity FPS	PSI Loss	Velocity FPS	PSI Loss	Velocity FPS	PSI Loss	Velocity FPS	PSI Loss	Velocity FPS	PSI Loss	Velocity FPS	PSI Loss
1	60	1.06	0.91	0.60	0.23	0.37	0.07	0.21	0.02	0.16	0.01	0.10	0.00	0.07	0.00	0.04	0.00	0.03	0.00	0.01	0.00
2	120	2.11	3.28	1.20	0.84	0.74	0.26	0.43	0.07	0.32	0.03	0.19	0.01	0.13	0.00	0.09	0.00	0.05	0.00	0.02	0.00
3	180	3.17	6.95	1.80	1.77	1.11	0.55	0.64	0.14	0.47	0.07	0.29	0.02	0.20	0.01	0.13	0.00	0.08	0.00	0.03	0.00
4	240	4.22	11.85	2.41	3.02	1.48	0.93	0.86	0.25	0.63	0.12	0.38	0.03	0.27	0.01	0.17	0.01	0.10	0.00	0.04	0.00
5	300	5.28	17.91	3.01	4.56	1.86	1.41	1.07	0.37	0.79	0.18	0.48	0.05	0.34	0.02	0.22	0.01	0.13	0.00	0.06	0.00
6	360	6.34	25.10	3.61	6.39	2.23	1.97	1.29	0.52	0.95	0.25	0.57	0.07	0.40	0.03	0.26	0.01	0.15	0.00	0.07	0.00
7	420	7.39	33.40	4.21	8.50	2.60	2.63	1.50	0.69	1.10	0.33	0.67	0.10	0.47	0.04	0.30	0.01	0.18	0.00	0.08	0.00
8	480	8.45	42.77	4.81	10.88	2.97	3.36	1.72	0.89	1.26	0.42	0.76	0.12	0.54	0.05	0.35	0.02	0.20	0.00	0.09	0.00
9	540	9.50	53.19	5.41	13.54	3.34	4.18	1.93	1.10	1.42	0.52	0.86	0.15	0.60	0.06	0.39	0.02	0.23	0.01	0.10	0.00
10	600	10.56	64.65	6.02	16.45	3.71	5.08	2.15	1.34	1.58	0.63	0.96	0.19	0.67	0.08	0.43	0.03	0.25	0.01	0.11	0.00
11	660	11.61	77.14	6.62	19.63	4.08	6.06	2.36	1.60	1.73	0.75	1.05	0.22	0.74	0.09	0.48	0.03	0.28	0.01	0.12	0.00
12	720	12.67	90.62	7.22	23.06	4.45	7.12	2.57	1.88	1.89	0.89	1.15	0.26	0.80	0.11	0.52	0.04	0.30	0.01	0.13	0.00
14	840			8.42	30.68	5.20	9.48	3.00	2.50	2.21	1.18	1.34	0.35	0.94	0.15	0.61	0.05	0.35	0.01	0.16	0.00
16	960			9.63	39.29	5.94	12.14	3.43	3.20	2.52	1.51	1.53	0.45	1.07	0.19	0.69	0.07	0.40	0.02	0.18	0.00
18	1,080			10.83	48.87	6.68	15.10	3.86	3.97	2.84	1.88	1.72	0.56	1.21	0.23	0.78	0.08	0.45	0.02	0.20	0.00
20	1,200			12.03	59.40	7.42	18.35	4.29	4.83	3.15	2.28	1.91	0.68	1.34	0.28	0.87	0.10	0.50	0.03	0.22	0.00
22	1,320			13.24	70.87	8.17	21.89	4.72	5.76	3.47	2.72	2.10	0.81	1.47	0.34	0.95	0.12	0.55	0.03	0.24	0.00
24	1,440					8.91	25.72	5.15	6.77	3.78	3.20	2.29	0.95	1.61	0.40	1.04	0.14	0.60	0.04	0.27	0.01
26	1,560					9.65	29.83	5.58	7.85	4.10	3.71	2.49	1.10	1.74	0.46	1.13	0.16	0.66	0.04	0.29	0.01
28	1,680					10.39	34.22	6.01	9.01	4.41	4.25	2.68	1.26	1.88	0.53	1.22	0.18	0.71	0.05	0.31	0.01
30	1,800					11.14	38.88	6.44	10.24	4.73	4.83	2.87	1.43	2.01	0.60	1.30	0.21	0.76	0.06	0.33	0.01
35	2,100					12.99	51.72	7.51	13.62	5.52	6.43	3.35	1.91	2.35	0.80	1.52	0.28	0.88	0.07	0.39	0.01
40	2,400							8.58	17.44	6.30	8.24	3.82	2.44	2.68	1.03	1.74	0.36	1.01	0.10	0.44	0.01
45	2,700							9.65	21.69	7.09	10.25	4.30	3.04	3.02	1.28	1.95	0.44	1.13	0.12	0.50	0.02
50	3,000							10.73	26.36	7.88	12.45	4.78	3.69	3.35	1.55	2.17	0.54	1.26	0.14	0.56	0.02
55	3,300							11.80	31.45	8.67	14.86	5.26	4.40	3.69	1.85	2.39	0.64	1.39	0.17	0.61	0.02
60	3,600							12.87	36.95	9.46	17.45	5.74	5.17	4.02	2.18	2.60	0.76	1.51	0.20	0.67	0.03
65	3,900							13.94	42.86	10.24	20.24	6.21	6.00	4.36	2.53	2.82	0.88	1.64	0.23	0.72	0.03
70	4,200									11.03	23.22	6.69	6.88	4.69	2.90	3.04	1.01	1.76	0.27	0.78	0.04
75	4,500									11.82	26.39	7.17	7.82	5.03	3.29	3.25	1.14	1.89	0.31	0.83	0.04
80	4,800									12.61	29.74	7.65	8.82	5.36	3.71	3.47	1.29	2.02	0.34	0.89	0.05
85	5,100									13.40	33.27	8.13	9.86	5.70	4.15	3.69	1.44	2.14	0.38	0.94	0.05
90	5,400											8.61	10.96	6.03	4.62	3.91	1.60	2.27	0.43	1.00	0.06
95	5,700											9.08	12.12	6.37	5.10	4.12	1.77	2.39	0.47	1.06	0.06
100	6,000											9.56	13.33	6.70	5.61	4.34	1.95	2.52	0.52	1.11	0.07
110	6,600											10.52	15.90	7.37	6.70	4.77	2.33	2.77	0.62	1.22	0.08
120	7,200											11.47	18.68	8.04	7.87	5.21	2.73	3.02	0.73	1.33	0.10
130	7,800											12.43	21.66	8.71	9.12	5.64	3.17	3.28	0.85	1.44	0.12
140	8,400											13.39	24.85	9.38	10.47	6.08	3.64	3.53	0.97	1.55	0.13
150	9,000													10.05	11.89	6.51	4.13	3.78	1.10	1.67	0.15
160	9,600													10.72	13.40	6.94	4.66	4.03	1.24	1.78	0.17
170	10,200													11.39	15.00	7.38	5.21	4.28	1.39	1.89	0.19
180	10,800													12.06	16.67	7.81	5.79	4.54	1.54	2.00	0.21
190	11,400													12.73	18.43	8.25	6.40	4.79	1.71	2.11	0.23
200	12,000													13.40	20.26	8.68	7.04	5.04	1.88	2.22	0.26
225	13,500															9.76	8.76	5.67	2.33	2.50	0.32
250	15,000															10.85	10.64	6.30	2.84	2.78	0.39
275	16,500															11.93	12.70	6.93	3.38	3.05	0.46
300	18,000															13.02	14.92	7.56	3.98	3.33	0.54
325	19,500																	8.19	4.61	3.61	0.63
350	21,000																	8.82	5.29	3.89	0.72
375	22,500																	9.45	6.01	4.16	0.82
400	24,000																	10.08	6.77	4.44	0.92
425	25,500																	10.71	7.58	4.72	1.03
450	27,000																	11.34	8.43	5.00	1.15
475	28,500																	11.97	9.31	5.28	1.27
500	30,000																	12.60	10.24	5.55	1.39
550	33,000																	13.86	12.22	6.11	1.66
600	36,000																			6.66	1.95
650	39,000																			7.22	2.27
700	42,000																			7.77	2.60
750	45,000																			8.33	2.95
800	48,000																			8.88	3.33
850	51,000																			9.44	3.73
900	54,000																			9.99	4.14

**Note:** Shaded areas of the chart indicate velocities over 5 Ft/Sec. Use with Caution.

Velocities are calculated using the general equation:

$$V = (0.4085 * (Q / d^2))$$

Friction Losses are calculated using the Hazen-Williams Equation:

$$H_f = 0.2083 * (100 / C)^{1.852} * (Q^{1.852} / d^{4.866})$$

V = FPS (feet per second)

H<sub>f</sub> = PSI/100 Ft. (pounds per square inch per 100 feet)

C = 100

Q = GPM (gallons per minute)

d = ID (inside diameter)

# WASTEWATER REUSE AND DRIP DISPERSAL GUIDE

## FRICTION LOSS CHARACTERISTICS TYPE K COPPER

*C=140*  
Sizes 1/2" to 3"  
Flows 1 to 450 GPM

**PSI Loss of 100 Feet of Pipe (psi per 100 feet)**

SIZE		1/2"		5/8"		3/4"		1"		1 1/4"		1 1/2"		2"		2 1/2"		3"	
I.D.		0.527"		0.652"		0.745"		0.995"		1.245"		1.481"		1.959"		2.435"		2.907"	
O.D.		0.625"		0.750"		0.875"		1.125"		1.375"		1.625"		2.125"		2.625"		3.125"	
Wall Thk		0.049"		0.049"		0.065"		0.065"		0.065"		0.072"		0.083"		0.095"		0.109"	
Flow GPM	Flow GPH	Velocity FPS	PSI Loss	Velocity FPS	PSI Loss	Velocity FPS	PSI Loss	Velocity FPS	PSI Loss	Velocity FPS	PSI Loss	Velocity FPS	PSI Loss	Velocity FPS	PSI Loss	Velocity FPS	PSI Loss	Velocity FPS	PSI Loss
1	60	1.47	1.09	0.96	0.39	0.74	0.20	0.41	0.05	0.26	0.02	0.19	0.01	0.11	0.00	0.07	0.00	0.05	0.00
2	120	2.94	3.94	1.92	1.40	1.47	0.73	0.83	0.18	0.53	0.06	0.37	0.03	0.21	0.01	0.14	0.00	0.10	0.00
3	180	4.41	8.35	2.88	2.97	2.21	1.55	1.24	0.38	0.79	0.13	0.56	0.05	0.32	0.01	0.21	0.00	0.15	0.00
4	240	5.88	14.23	3.84	5.05	2.94	2.64	1.65	0.65	1.05	0.22	0.74	0.09	0.43	0.02	0.28	0.01	0.19	0.00
5	300	7.35	21.51	4.80	7.64	3.68	3.99	2.06	0.98	1.32	0.33	0.93	0.14	0.53	0.04	0.34	0.01	0.24	0.01
6	360	8.83	30.15	5.77	10.70	4.42	5.59	2.48	1.37	1.58	0.46	1.12	0.20	0.64	0.05	0.41	0.02	0.29	0.01
7	420	10.30	40.12	6.73	14.24	5.15	7.44	2.89	1.82	1.84	0.61	1.30	0.26	0.75	0.07	0.48	0.02	0.34	0.01
8	480	11.77	51.37	7.69	18.24	5.89	9.53	3.30	2.33	2.11	0.78	1.49	0.34	0.85	0.09	0.55	0.03	0.39	0.01
9	540	13.24	63.90	8.65	22.68	6.62	11.85	3.71	2.90	2.37	0.97	1.68	0.42	0.96	0.11	0.62	0.04	0.44	0.02
10	600			9.61	27.57	7.36	14.41	4.13	3.52	2.64	1.18	1.86	0.51	1.06	0.13	0.69	0.05	0.48	0.02
11	660			10.57	32.89	8.10	17.19	4.54	4.21	2.90	1.41	2.05	0.61	1.17	0.16	0.76	0.05	0.53	0.02
12	720			11.53	38.64	8.83	20.20	4.95	4.94	3.16	1.66	2.23	0.71	1.28	0.18	0.83	0.06	0.58	0.03
14	840			13.45	51.41	10.30	26.87	5.78	6.57	3.69	2.21	2.61	0.95	1.49	0.24	0.96	0.08	0.68	0.04
16	960					11.78	34.41	6.60	8.42	4.22	2.83	2.98	1.22	1.70	0.31	1.10	0.11	0.77	0.05
18	1,080					13.25	42.80	7.43	10.47	4.74	3.52	3.35	1.51	1.92	0.39	1.24	0.13	0.87	0.06
20	1,200							8.25	12.72	5.27	4.28	3.72	1.84	2.13	0.47	1.38	0.16	0.97	0.07
22	1,320							9.08	15.18	5.80	5.10	4.10	2.19	2.34	0.56	1.52	0.19	1.06	0.08
24	1,440							9.90	17.84	6.33	5.99	4.47	2.58	2.55	0.66	1.65	0.23	1.16	0.10
26	1,560							10.73	20.69	6.85	6.95	4.84	2.99	2.77	0.77	1.79	0.27	1.26	0.11
28	1,680							11.55	23.73	7.38	7.97	5.21	3.43	2.98	0.88	1.93	0.30	1.35	0.13
30	1,800							12.38	26.96	7.91	9.06	5.59	3.89	3.19	1.00	2.07	0.35	1.45	0.15
35	2,100									9.22	12.05	6.52	5.18	3.73	1.33	2.41	0.46	1.69	0.19
40	2,400									10.54	15.43	7.45	6.63	4.26	1.70	2.76	0.59	1.93	0.25
45	2,700									11.86	19.20	8.38	8.25	4.79	2.11	3.10	0.73	2.18	0.31
50	3,000									13.18	23.33	9.31	10.03	5.32	2.57	3.44	0.89	2.42	0.38
55	3,300											10.24	11.96	5.85	3.07	3.79	1.06	2.66	0.45
60	3,600											11.17	14.05	6.39	3.60	4.13	1.25	2.90	0.53
65	3,900											12.11	16.30	6.92	4.18	4.48	1.45	3.14	0.61
70	4,200											13.04	18.70	7.45	4.79	4.82	1.66	3.38	0.70
75	4,500											13.97	21.24	7.98	5.45	5.17	1.89	3.63	0.80
80	4,800													8.52	6.14	5.51	2.13	3.87	0.90
85	5,100													9.05	6.87	5.86	2.38	4.11	1.01
90	5,400													9.58	7.63	6.20	2.65	4.35	1.12
95	5,700													10.11	8.44	6.55	2.93	4.59	1.24
100	6,000													10.64	9.28	6.89	3.22	4.83	1.36
110	6,600													11.71	11.07	7.58	3.84	5.32	1.62
120	7,200													12.77	13.01	8.27	4.51	5.80	1.91
130	7,800													13.84	15.08	8.96	5.23	6.28	2.21
140	8,400														9.65	6.00	6.77	2.54	
150	9,000														10.33	6.82	7.25	2.88	
160	9,600														11.02	7.69	7.73	3.25	
170	10,200														11.71	8.60	8.22	3.63	
180	10,800														12.40	9.56	8.70	4.04	
190	11,400														13.09	10.57	9.18	4.46	
200	12,000														13.78	11.62	9.67	4.91	
225	13,500																10.88	6.10	
250	15,000																12.08	7.42	
275	16,500																13.29	8.85	
300	18,000																		
325	19,500																		
350	21,000																		
375	22,500																		
400	24,000																		
425	25,500																		
450	27,000																		

**Note:** Shaded areas of the chart indicate velocities over 5 Ft/Sec. Use with Caution.

Velocities are calculated using the general equation:  
 $V = (0.4085 * (Q / d^2))$

Friction Losses are calculated using the Hazen-Williams Equation:  
 $H_f = 0.2083 * (100 / C)^{1.852} * (Q^{1.852} / d^{4.866})$

V = FPS (feet per second)

H<sub>f</sub> = PSI/100 Ft. (pounds per square inch per 100 feet)

C = 140

Q = GPM (gallons per minute)

d = ID (inside diameter)

# WASTEWATER REUSE AND DRIP DISPERSAL GUIDE

## ROUND TANK CAPACITY

*Round Tank Capacity (U. S. Gallons for Every One Foot of Depth)*

Diameter of Tank	Capacity U. S. Gal.	Cu. Ft. & Area Sq. Ft.	Diameter of Tank	Capacity U. S. Gal.	Cu. Ft. & Area Sq. Ft.	Diameter of Tank	Capacity U. S. Gal.	Diameter of Tank	Capacity U. S. Gal.
1' 0"	5.87	.785	4' 0"	94.00	12.566	9' 0"	475.89	18' 0"	1,903.60
1' 1"	6.89	.922	4' 1"	97.96	13.095	9' 3"	502.70	18' 3"	1,956.80
1' 2"	8.00	1.069	4' 2"	102.00	13.635	9' 6"	530.24	18' 6"	2,010.80
1' 3"	9.18	1.227	4' 3"	106.12	14.186	9' 9"	558.51	18' 9"	2,065.50
1' 4"	10.44	1.396	4' 4"	110.32	14.748	10' 0"	587.52	19' 0"	2,120.90
1' 5"	11.79	1.576	4' 5"	114.61	15.321	10' 3"	617.26	19' 3"	2,177.10
1' 6"	13.22	1.767	4' 6"	118.97	15.90	10' 6"	647.74	19' 6"	2,234.00
1' 7"	14.73	1.969	4' 7"	123.42	16.60	10' 9"	678.95	19' 9"	2,291.70
1' 8"	16.32	2.182	4' 8"	127.95	17.10	11' 0"	710.90	20' 0"	2,350.10
1' 9"	17.99	2.405	4' 9"	132.56	17.72	11' 3"	743.58	20' 3"	2,409.20
1' 10"	19.75	2.640	4' 10"	138.25	18.35	11' 6"	776.99	20' 6"	2,469.10
1' 11"	21.58	2.885	4' 11"	142.02	18.99	11' 9"	811.14	20' 9"	2,529.60
2' 0"	23.50	3.142	5' 0"	146.88	19.63	12' 0"	846.03	21' 0"	2,591.00
2' 1"	25.50	3.409	5' 1"	151.82	20.29	12' 3"	881.65	21' 3"	2,653.00
2' 2"	27.58	3.687	5' 2"	156.83	20.97	12' 6"	918.00	21' 6"	2,715.80
2' 3"	29.74	3.975	5' 3"	161.93	21.65	12' 9"	955.09	21' 9"	2,779.30
2' 4"	31.99	4.276	5' 4"	167.12	22.34	13' 0"	992.91	22' 0"	2,843.60
2' 5"	34.31	4.587	5' 5"	172.38	23.04	13' 3"	1,031.50	22' 3"	2,908.60
2' 6"	36.72	4.909	5' 6"	177.72	23.76	13' 6"	1,070.80	22' 6"	2,974.30
2' 7"	39.21	5.241	5' 7"	183.15	24.48	13' 9"	1,110.80	22' 9"	3,040.80
2' 8"	41.78	5.585	5' 8"	188.66	25.22	14' 0"	1,151.50	23' 0"	3,108.00
2' 9"	44.43	5.940	5' 9"	194.25	25.97	14' 3"	1,193.00	23' 3"	3,175.90
2' 10"	47.16	6.305	5' 10"	199.92	26.73	14' 6"	1,235.30	23' 6"	3,244.60
2' 11"	49.98	6.681	5' 11"	205.67	27.49	14' 9"	1,278.20	23' 9"	3,314.00
3' 0"	52.88	7.069	6' 0"	211.51	28.27	15' 0"	1,321.90	24' 0"	3,384.10
3' 1"	55.86	7.467	6' 3"	229.50	30.68	15' 3"	1,366.40	24' 3"	3,455.00
3' 2"	58.92	7.876	6' 6"	248.23	33.18	15' 6"	1,411.50	24' 6"	3,526.60
3' 3"	62.06	8.296	6' 9"	267.69	35.78	15' 9"	1,457.40	24' 9"	3,599.90
3' 4"	65.28	8.727	7' 0"	287.88	38.48	16' 0"	1,504.10	25' 0"	3,672.00
3' 5"	68.58	9.168	7' 3"	308.81	41.28	16' 3"	1,551.40	25' 3"	3,745.80
3' 6"	71.97	9.621	7' 6"	330.48	44.18	16' 6"	1,599.50	25' 6"	3,820.30
3' 7"	75.44	10.085	7' 9"	352.88	47.17	16' 9"	1,648.40	25' 9"	3,895.60
3' 8"	78.99	10.559	8' 0"	376.01	50.27	17' 0"	1,697.90	26' 0"	3,971.60
3' 9"	82.62	11.045	8' 3"	399.88	53.46	17' 3"	1,748.20	26' 3"	4,048.40
3' 10"	86.33	11.541	8' 6"	421.48	56.75	17' 6"	1,799.30	26' 6"	4,125.90
3' 11"	90.13	12.048	8' 9"	449.82	60.13	17' 9"	1,851.10	26' 9"	4,204.10

## RECTANGULAR TANK CAPACITY

*Rectangular Tank Capacity (U. S. Gallons for Every One Foot of Depth)*

	2'	2'6"	3'	3'6"	4'	4'6"	5'	5'6"	6'	6'6"	7'	7'6"	8'	8'6"	9'	9'6"	10'	10'6"	11'	11'6"	12'
2'	30	37	45	52	60	67	75	82	90	97	105	112	120	127	135	142	150	157	165	172	180
2'6"		47	56	65	75	84	94	103	112	122	131	140	150	159	168	178	187	196	206	215	224
3'			67	79	90	101	112	123	135	146	157	168	180	191	202	213	224	236	247	258	269
3'6"				92	105	118	131	144	157	170	183	196	209	223	236	249	262	275	288	301	314
4'					120	135	150	165	180	194	209	224	239	254	269	284	299	314	329	344	359
4'6"						151	168	185	202	219	236	252	269	286	303	320	337	353	370	387	404
5'							187	206	224	243	262	281	299	318	337	355	374	393	411	430	449
5'6"								226	247	267	288	309	329	350	370	391	411	432	453	473	494
6'									269	292	314	337	359	381	404	426	449	471	494	516	539
6'6"										316	340	365	389	413	438	462	486	511	535	559	583
7'											367	393	419	445	471	497	524	550	576	602	628
7'6"												421	449	477	505	533	561	589	617	645	673
8'													479	509	539	568	598	628	658	688	718
8'6"														540	572	604	636	668	699	731	763
9'															606	640	673	707	741	774	808
9'6"																675	711	746	782	817	853
10'																	748	785	823	860	898
10'6"																		825	864	903	942
11'																			905	946	987
11'6"																				989	1,032
12'																					1,077

# WASTEWATER REUSE AND DRIP DISPERSAL GUIDE

## CONVERSION CHARTS

Multiply Units In Left Column By Conversion Number

Length								
Units →	inches	feet	yard	mile	mm	cm	m	km
1 Inch	1	0.0833	0.0278	-	25.4	2.540	0.0254	-
1 Foot	12	1	0.3333	-	304.8	30.48	0.3048	-
1 Yard	36	3	1	-	914.4	91.44	0.9144	-
1 Mile	-	5280	1760	1	-	-	1609.3	1.609
1 Millimeter	0.0394	0.0033	-	-	1	0.100	0.001	-
1 Centimeter	0.3937	0.0328	0.0109	-	10	1	0.01	-
1 Meter	39.37	3.281	1.094	-	1000	100	1	0.001
1 Kilometer	-	3281	1094	0.6214	-	-	1000	1

Weight							
Units →	grain	ounce	pound	ton	gram	kg	metric ton
1 Ounce	437.5	1	0.0625	-	28.35	0.0283	-
1 Pound	7000	16	1	0.0005	453.6	0.4536	-
1 Ton	-	32,000	2000	1	-	907.2	0.9072
1 Gram	15.43	0.0353	-	-	1	0.001	-
1 Kilogram	-	35.27	2.205	-	1000	1	0.001
1 Metric Ton	-	35,274	2205	1.1023	-	1000	1

Density					
Units →	lb/in <sup>3</sup>	lb/ft <sup>3</sup>	lb/gal	g/cm <sup>3</sup>	g/liter
1 Pound/in <sup>3</sup>	1	1728	231.0	27.68	27.680
1 Pound/ft <sup>3</sup>	-	1	0.1337	0.0160	16.019
1 Pound/gal	0.00433	7.481	1	0.1198	119.83
1 Gram/cm <sup>3</sup>	0.0361	62.43	8.345	1	1000.0
1 Gram/liter	-	0.0624	0.00835	0.001	1

Area							
Units →	inches <sup>2</sup>	feet <sup>2</sup>	acre	mile <sup>2</sup>	cm <sup>2</sup>	m <sup>2</sup>	hectare
1 Inch <sup>2</sup>	1	0.0069	-	-	6.452	-	-
1 Foot <sup>2</sup>	144	1	-	-	929.0	0.0929	-
1 Acre	-	43,560	1	0.0016	-	4047	0.4047
1 Mile <sup>2</sup>	-	-	640	1	-	-	259.0
1 Centimeter <sup>2</sup>	0.1550	-	-	-	1	0.0001	-
1 Meter <sup>2</sup>	1550	10.76	-	-	10,000	1	-
1 Hectare	-	-	2.471	-	-	10,000	1

Volume								
Units →	inches <sup>3</sup>	feet <sup>3</sup>	yards <sup>3</sup>	cm <sup>3</sup>	meter <sup>3</sup>	liter	U.S. Gallon	Imp. Gallon
1 Inch <sup>3</sup>	1	-	-	16.387	-	0.0164	-	-
1 Foot <sup>3</sup>	1728	1	0.0370	28.317	0.0283	28.32	7.481	6.229
1 Yard <sup>3</sup>	46.656	27	1	-	0.7646	764.5	202.0	168.2
1 Centimeter <sup>3</sup>	0.0610	-	-	1	-	0.0010	-	-
1 Meter <sup>3</sup>	61.023	35.31	1.308	1,000	1	999.97	264.2	220.0
1 Liter	61.025	0.0353	-	1000.028	0.0010	1	0.2642	0.22
1 U.S. Gallon	231	0.1337	-	3785.4	-	3.785	1	0.8327
1 Imp. Gallon	277.4	0.1605	-	4546.1	-	4.546	1.201	1

# WASTEWATER REUSE AND DRIP DISPERSAL GUIDE

## FRICITION LOSS THROUGH FITTINGS

Friction Loss*																		
Item	½"	¾"	1"	1 ¼"	1 ½"	2"	2 ½"	3"	4"	6"	8"	10"	12"	14"	16"	18"	20"	24"
Tee Run	1.0	1.4	1.7	2.3	2.7	4.0	4.9	6.1	7.9	12.3	14.0	17.5	20.0	25.0	27.0	32.0	35.0	42.0
Tee Branch	3.8	4.9	6.0	7.3	8.4	12.0	14.7	16.4	22.0	32.7	49.0	57.0	67.0	78.0	88.0	107.0	118.0	137.0
90° Elbow	1.5	2.0	2.5	3.8	4.0	5.7	6.9	7.9	11.4	16.7	21.0	26.0	32.0	37.0	43.0	53.0	58.0	67.0
45° Elbow	.8	1.1	1.4	1.8	2.1	2.6	3.1	4.0	5.1	8.0	10.6	13.5	15.5	18.0	20.0	23.0	25.0	30.0

\* Friction loss through fittings is expressed in equivalent feet of the same pipe schedule and size for the system flow rate. Sch40 head loss per 100 feet values are commonly used for other wall thicknesses and standard iron pipe size O.D.s.

## THERMAL EXPANSION

Thermal Expansion (ΔL) of PVC Pipe (inches)										
Temperature Change ΔTF	Length of Run in Feet									
	10	20	30	40	50	60	70	80	90	100
20	.07	.14	.22	.29	.36	.43	.50	.58	.65	.72
30	.11	.22	.32	.43	.54	.65	.76	.86	.97	1.08
40	.14	.29	.43	.58	.72	.86	1.01	1.15	1.30	1.44
50	.18	.36	.54	.72	.90	1.08	1.26	1.40	1.62	1.80
60	.22	.43	.65	.86	1.08	1.30	1.51	1.73	1.94	2.16
70	.25	.50	.76	1.01	1.26	1.51	1.76	2.02	2.27	2.52
80	.29	.58	.86	1.15	1.44	1.73	2.02	2.30	2.59	2.88
90	.32	.65	.97	1.30	1.62	1.94	2.27	2.59	2.92	3.24
100	.36	.72	1.03	1.44	1.80	2.16	2.52	2.88	3.24	3.60

Thermal Expansion (ΔL) of PE Pipe (inches) = 0.3"/100' per each 1°C change.

## CONTENTS OF A PIPE

Contents of Pipe			
Diameter (inches)	Diameter (feet)	For One Foot Length	
		Cubic Feet	U.S. Gallons (231 inches <sup>3</sup> )
½	.0417	.0014	.0102
¾	.0625	.0031	.0230
1	.0833	.0055	.0408
2	.1667	.0218	.1632
3	.2500	.0491	.3673
4	.3333	.0873	.6528
6	.5000	.1963	1.469
8	.6667	.3490	2.611
10	.8333	.5455	4.081
12	1.000	.7854	5.876
16	1.333	1.396	10.44



## CONVERSION FORMULAS AND FACTORS

### Volume of a Pipe

$$\text{Pipe} = ID^2 \times \pi \times L \times 3$$

<b>Where</b>	V =	volume (cubic inches)
	ID =	Inside diameter (inches)
	$\pi$ =	3.14159
	L =	length of pipe (feet)

### Weight

1 U.S. gallon @ 50° F	=	8.33 lbs. x specific gravity
1 cubic foot	=	62.35 lbs. x specific gravity
1 cubic foot	=	7.48 U.S. gal.
1 cu. ft. of water @ 50° F	=	62.41 lbs.
1 cu. ft. of water @ 39.2° F	=	62.43 lbs. (39.2° F is water temp. at its greatest density)
1 kilogram	=	2.2 lbs.
1 imperial gallon of water	=	10.0 lbs.
1 pound	=	12 U.S. gal. ÷ by specific gravity
1 pound	=	.016 cu. ft. ÷ by specific gravity

### Velocity

$$V \text{ ft./sec.} = \frac{0.4085 \times \text{Flow (GPM)}}{\text{Pipe I.D. (in)}^2}$$

$$V \text{ m./sec.} = \frac{1273.24 \times \text{Flow (L/sec)}}{\text{Pipe I.D. (mm)}^2}$$

### Capacity or Flow

1 cu. ft. minute (cfm)	=	449 GPH
1 cu. ft. second (cfs)	=	449 GPM
1 acre foot per day	=	227 GPM
1 acre inch per hour	=	454 GPM
1 cubic meter per minute	=	264.2 GPM
1,000,000 gal. per day	=	595 GPM

### Slope

$$S = \frac{\text{Rise}}{\text{Run}}$$

# WASTEWATER REUSE AND DRIP DISPERSAL GUIDE

## PRESSURE LOSS THROUGH WATER METERS

*Pressure Loss Through Water Meters (AWWA Standard)*

Flow (GPM) Meters AWWA Standard	5/8"	3/4"	1"	1 1/2"	2"	3"	4"
1	0.2	0.1					
2	0.3	0.2					
3	0.4	0.3					
4	0.6	0.5	0.1				
5	0.9	0.6	0.2				
6	1.3	0.7	0.3				
7	1.8	0.8	0.4				
8	2.3	1.0	0.5				
9	3.0	1.3	0.6				
10	3.7	1.6	0.7				
11	4.4	1.9	0.8				
12	5.1	2.2	0.9				
13	6.1	2.6	1.0				
14	7.2	3.1	1.1				
15	8.3	3.6	1.2				
16	9.4	4.1	1.4	0.4			
17	10.7	4.6	1.6	0.5			
18	12.0	5.2	1.8	0.6			
19	13.4	5.8	2.0	0.7			
20	15.0	6.5	2.2	0.8			
22		7.9	2.8	1.0			
24		9.5	3.4	1.2			
26		11.2	4.0	1.4			
28		13.0	4.6	1.6			
30		15.0	5.3	1.8			
32			6.0	2.1	0.8		
34			6.9	2.4	0.9		
36			7.8	2.7	1.0		
38			8.7	3.0	1.2		
40			9.6	3.3	1.3		
42			10.6	3.6	1.4		
44			11.7	3.9	1.5		
46			12.8	4.2	1.6		
48			13.9	4.5	1.7		
50			15.0	4.9	1.9		
52				5.3	2.1		
54				5.7	2.2		
56				6.2	2.3		
58				6.7	2.5		
60				7.2	2.7	1.0	
65				8.3	3.2	1.1	
70				9.8	3.7	1.3	
75				11.2	4.3	1.5	
80				12.8	4.9	1.6	0.7
90				16.1	6.2	2.0	0.8
100				20.0	7.8	2.5	0.9
110					9.5	2.9	1.0
120					11.3	3.4	1.2
130					13.0	3.9	1.4
140					15.1	4.5	1.6
150					17.3	5.1	1.8
160					20.0	5.8	2.1
170						6.5	2.4
180						7.2	2.7
190						8.0	3.0
200						9.0	3.2
220						11.0	3.9
240						13.0	4.7
260						15.0	5.5
280						17.3	6.3
300						20.0	7.2
350							10.0
400							13.0
450							16.2
500							20.0

# WASTEWATER REUSE AND DRIP DISPERSAL GUIDE

## TEMPERATURE CONVERSION

<i>Temperature Conversion</i>											
°F	°C	°F	°C	°F	°C	°F	°C	°F	°C	°F	°C
-450	-268	-180	-118	10	-12.2	38	3.3	66	18.9	94	34.4
-440	-262	-170	-112	11	-11.7	39	3.9	67	19.4	95	35.0
-430	-257	-160	-107	12	-11.1	40	4.4	68	20.0	95	35.6
-420	-251	-150	-101	13	-10.6	41	5.0	69	20.6	97	36.1
-410	-246	-140	-96	14	-10.0	42	5.6	70	21.1	98	36.7
-400	-240	-130	-90	15	-9.4	43	6.1	71	21.7	99	37.2
-390	-234	-120	-84	16	-8.9	44	6.7	72	22.2	100	37.8
-380	-229	-110	-79	17	-8.3	45	7.2	73	22.8	110	43
-370	-223	-100	-73	18	-7.8	46	7.8	74	23.3	120	49
-360	-218	-90	-68	19	-7.2	47	8.3	75	23.9	130	54
-350	-212	-80	-62	20	-6.7	48	8.9	76	24.4	140	60
-340	-207	-70	-57	21	-6.1	49	9.4	77	25.0	150	66
-330	-201	-60	-51	22	-5.6	50	10.0	78	25.6	160	71
-320	-196	-50	-46	23	-5.0	51	10.6	79	26.1	170	77
-310	-190	-40	-40	24	-4.4	52	11.1	80	26.7	180	82
-300	-184	-30	-34	25	-3.9	53	11.7	81	27.2	190	88
-290	-179	-20	-29	26	-3.3	54	12.2	82	27.8	200	92
-280	-173	-10	-23	27	-2.8	55	12.8	83	28.3	210	99
-273	-169	0	-17.8	28	-2.2	56	13.3	84	28.9	212	100
-270	-168	1	-17.2	29	-1.7	57	13.9	85	29.4	220	104
-260	-162	2	-16.7	30	-1.1	58	14.4	86	30.0	230	110
-250	-157	3	-16.1	31	-0.6	59	15.0	87	30.6	240	116
-240	-151	4	-15.6	32	0.0	60	15.6	88	31.1	250	121
-230	-146	5	-15.0	33	0.6	61	16.1	89	31.7	260	127
-220	-140	6	-14.4	34	1.1	62	16.7	90	32.2	270	132
-210	-134	7	-13.9	35	1.7	63	17.2	91	32.8	280	138
-200	-129	8	-13.3	36	2.2	64	17.8	92	33.9	290	143
-190	-123	9	-12.8	37	2.8	65	18.3	93	33.9	300	149

Degrees Centigrade (°C) =  $\frac{5}{9} \times (°F - 32)$

Degrees Fahrenheit (°F) =  $\frac{9}{5} \times (°C + 32)$



NETAFIM USA  
5470 E. HOME AVE.  
FRESNO, CA 93727  
CS 888.638.2346  
F 800.695.4753  
[www.netafimusa.com](http://www.netafimusa.com)