

N E T A F I M

## 2" Compact LP Disc-Kleen Filter

### OPERATIONS, MAINTENANCE AND TROUBLESHOOTING GUIDE



**NETAFIM USA**  
5470 E. HOME AVE.  
FRESNO, CA 93727  
CS 888 638 2346  
F 800 695 4753  
[www.netafimusa.com](http://www.netafimusa.com)

# Table of Contents

Specifications .....	3
Water Quality & Maximum Flow Rates.....	4
Filter Operation .....	5
Installation .....	6
System Maintenance .....	8
Troubleshooting .....	11
Replacement Parts .....	14

# Specifications

- Maximum Operating Pressure: 90 psi
- Minimum Operating Pressure for Backflushing: 30 psi upstream during flush
- Minimum Backflush Flow: 35 GPM for Standard Model  
20 GPM for Low Flow Model
- Maximum Operating Temperature: 158° F
- Minimum Allowable pH: 5
- Inlet Connection: 2" Male Pipe Thread
- Outlet Connection: 2" Female Pipe Thread
- Flush Port Connection: 2" Female Pipe Thread
- Flush Valves: Reinforced Polyamide
- Filter Body and Cover: Polypropylene
- Filter Spine: Nylon
- Discs: Polypropylene

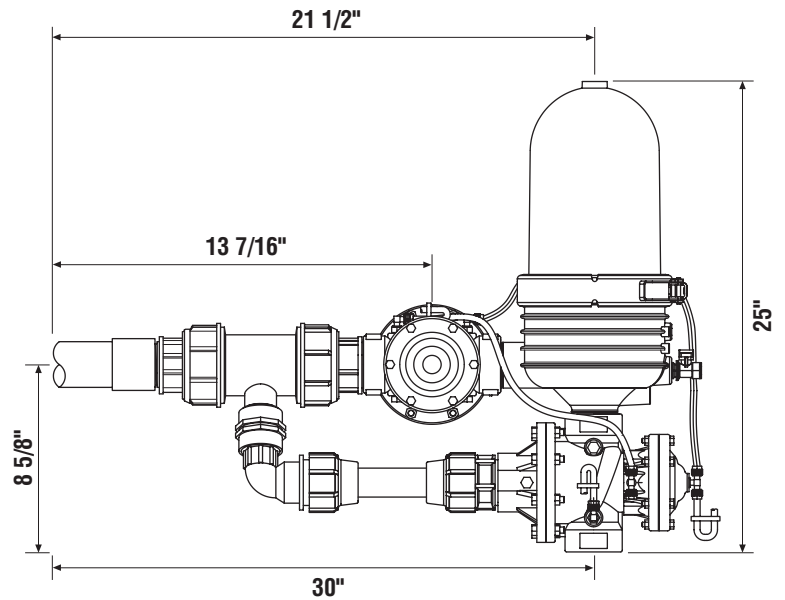
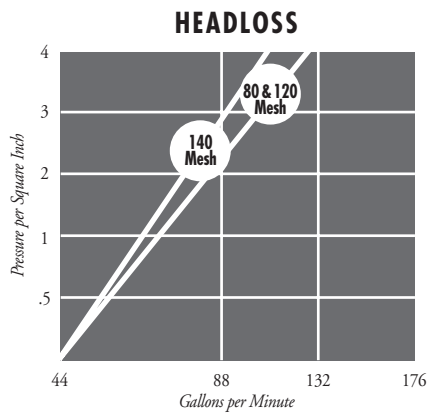
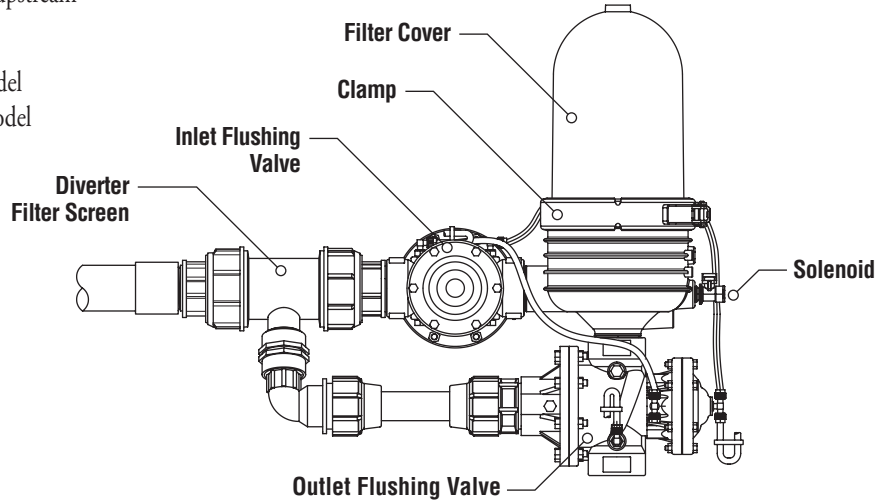

## DISC COLOR

Color	Yellow	Red	Black
Mesh	80	120	140

## DIMENSIONS

Inlet / Outlet	Inlet / Outlet Offset	Overall	Weight
21 1/2"	8 5/8"	30" x 25"	32 lbs.

# Water Quality & Maximum Flow Rates

## Water Quality

- **Good Water Quality:** Municipal water supply or well water from a clean aquifer with no sand, iron or manganese.
- **Average Water Quality:** Wells with small amounts of sand (< 2 ppm) or clean surface water which includes lakes, ponds, reservoirs and canals.
- **Poor Water Quality:** Well water with sand up to 10 ppm or surface water in hot climates with increased biological growth and no chemical treatment which includes lakes, ponds, reservoirs and canals.
- **Very Poor Water Quality:** Well water with greater than 10 ppm of sand including rivers, muddy canals, lakes and ponds with severe run off deposits and raw municipal wastewater.
- **Greater than 3 ppm Sand or Silt:** May require a pre-filter such as a hydrocyclone.

## Standard Flow Model Maximum Flow Rate (GPM)

Mesh Size →	80	120	140
Good	80	80	70
Average	70	70	60
Poor	55	55	50
Very Poor	35	35	30

## Low Flow Model Maximum Flow Rate (GPM)

Mesh Size →	80	120	140
Good	50	50	40
Average	40	40	30
Poor	30	30	20
Very Poor	20	20	10

# Filter Operation

The discs are stacked on the spine. The discs are color-coded by micron size and are assembled according to the water filtration requirements. The spine assembly has a spring compression unit and an internal piston which are used to alternately compress and release the discs during

filtration and backflush cycles. During filtration, water flows through the inlet flushing valve via the diverter filter tube and into the filter unit where it is cleaned. The filtered water then flows through the outlet flushing valve, clean for consumer use.

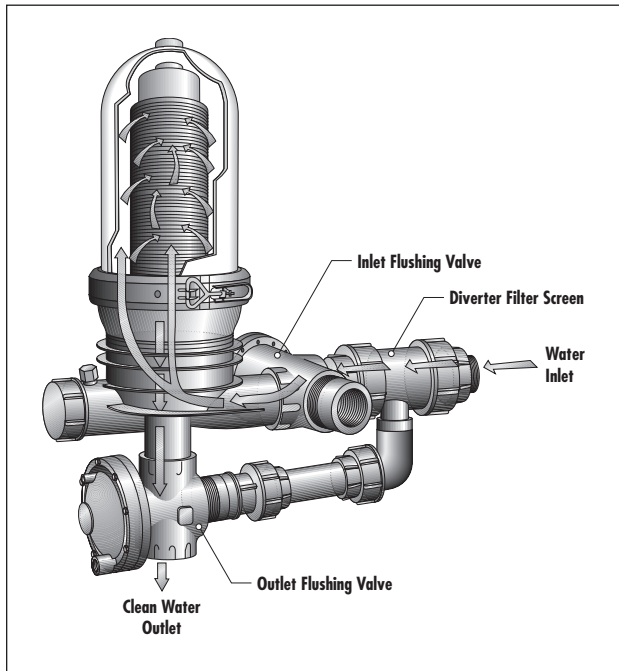

**Filtration Mode**

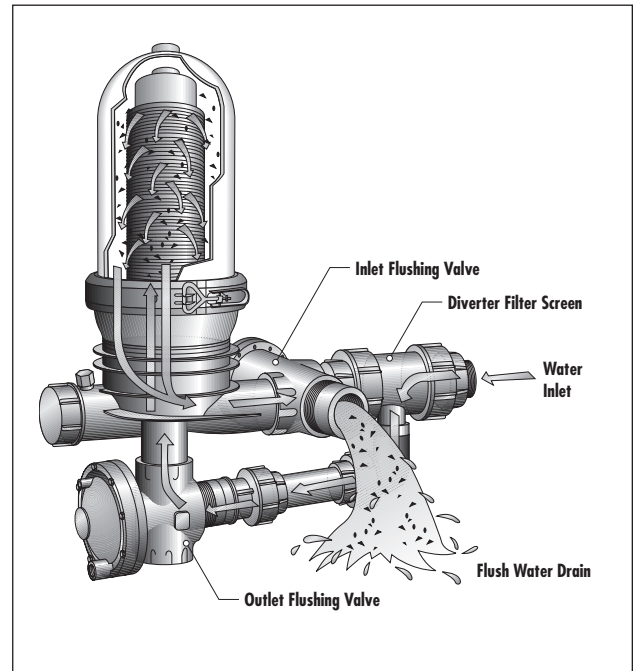

**Backflushing Mode**

## Filtration Mode:

During the filtration process the filter discs are tightly compressed together by the spring and the differential pressure, forcing the water to flow through the grooves and traps of the discs.

## Backflushing Mode:

Backflush commands, based on pressure differential or time settings, are sent from the controller to three separate components in the filter:

- Inlet Valve - Enters backflush mode (entrance closed, drain opens)
- Outlet Valve - Enters backflush mode (downstream closed, flush water diverter opens)
- Filter - Operational (stack of discs enters open mode)

Water flows via the diverter filter screen, through the diverter into the outlet flushing valve. It enters the main filter (which is open), where jets of water flush the grooves in the discs as the discs spin. The water carries away impurities toward the inlet valve.

At the end of the backflushing process (approximately 20 seconds), the backflush command is withdrawn, the discs are retightened and the filter returns to the filtration mode.

The inlet and outlet valves return to the filtering mode. Water flows once again into the filter, carrying with it the impurities that are collected on the diverter filter screen during backflushing.

# Installation

## Installation Steps:

- Install the filter making sure the flow of water follows the directional arrows on the filter (inlet and outlet).
- Connect a drain line to the flush drain of the backflush valve located in the front of the filter. The drain line should be at least 2" in diameter and not be longer than 30 feet. If a longer drain line is necessary, use a 3" diameter line. The drain water must flow freely with no back-pressure to the filter.
- Check that the filter cover is closed correctly.
- See Backflush Controller Programming on Page 7.
- Check the Pressure Differential (PD) gauge and make sure it is set to 5 psi.
- For DC Latching models, verify that the manual override green lever on the solenoid is in the vertical position - AUTO. For AC models, the dot on the brass knob faces down.
- Turn on the water to the filter. When the line is pressurized, initiate a backflush by turning the manual override on the solenoid to the left 90 degrees - FLUSH. The filter will go into the backflush mode and stay in the backflush mode as long as the manual override is to the left. Return to manual override to the vertical position (AUTO) and the filter will end the backflush cycle and return to filtration mode.

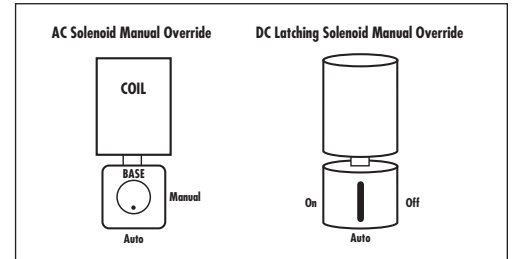

**IMPORTANT:** There must be at least 35 GPM at 30 psi at the upstream side of the filter during backflush for the filter to flush properly. The Low Flow model requires at least 20 GPM at 30 psi during backflush.

- Check the Pressure Differential (PD) gauge to make sure it is working. For Murphy PD gauges, unscrew the hydraulic tube on the Low Pressure port (the offset port) under the PD gauge. Water will squirt out of the tube. Direct the water away from you. By disconnecting the Low Pressure tube, the PD gauge will think that the downstream pressure is 0 psi. The long needle on the gauge should move to the set (short) needle, and a backflush will be initiated. There is a 25 - 30 second pre-dwell delay from the time the 2 needles make contact until the backflush begins.
- The backflush will last for 20 seconds, end, and the filter will return to filtration mode.
- The outlet valve will shut completely during the 20 second backflush. It will reopen when the backflush is complete.

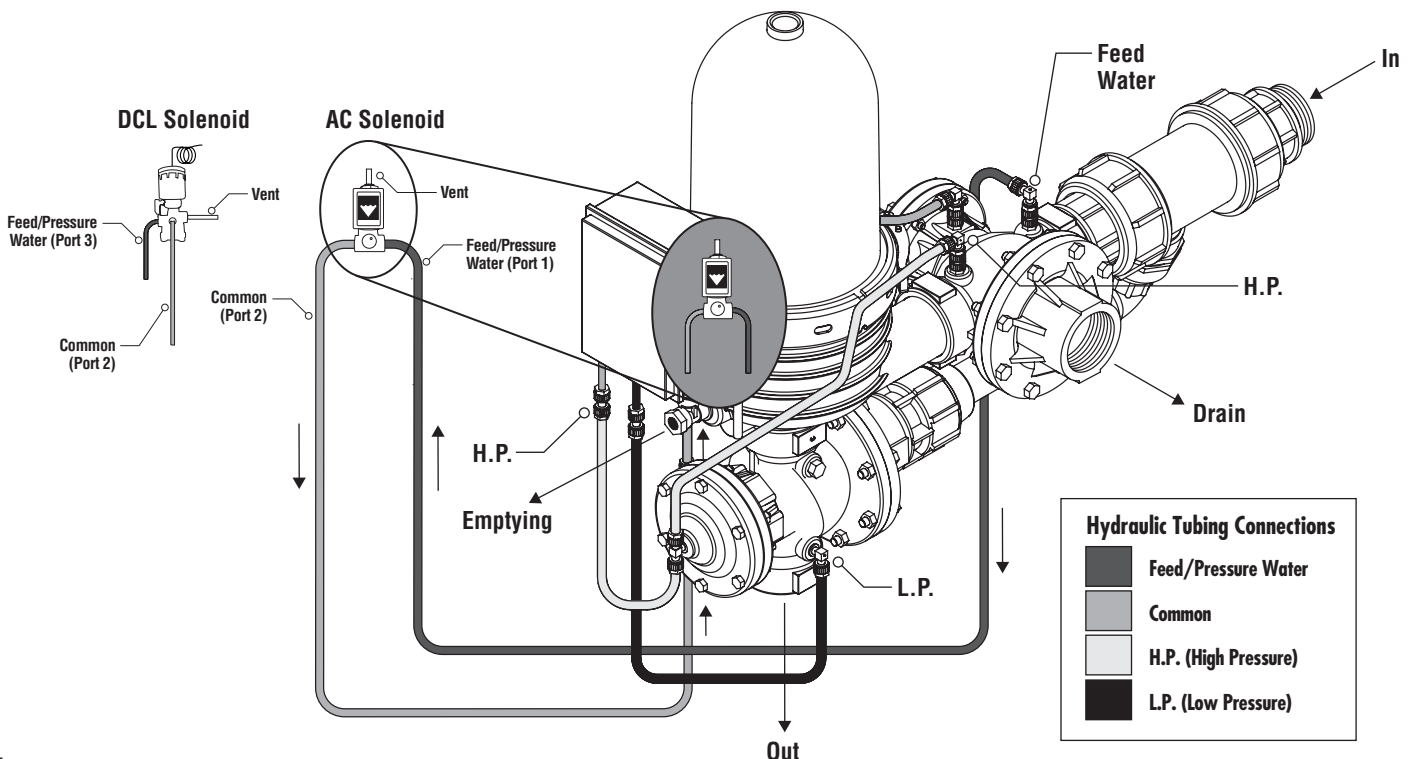

# Installation

## **Backflush Controller Programming – DC Latching Model:**

- Backflush Controller is two-station and operates two-wire latching solenoids.
- Attach the red solenoid wire to the (-) solenoid terminal marked S1. Attach the black solenoid wire to the (+) solenoid terminal marked S1.
- Select the PERIODIC FLUSH setting and set to 8 hours.
- Select the FLUSH setting and set to 20 seconds and DWELL to 0 seconds.
- Set the Pressure Differential (PD) to 5 psi.
- The PD delay is the interval from the time the PD sends a signal to start a backflush cycle and the time backflush actually starts. This delay insures that the filters are truly dirty before backflush is initiated. The PD delay is fixed at 30 seconds.
- The PERIODIC time resets itself after every cycle. To start the manual backflush, push the MANUAL START button for one second.

## **Backflush Controller Programming – AC Model:**

- Select solenoid output on the back of the circuit board by sliding the switch toward the edge of the circuit board for AC models.
- Select the PERIODIC FLUSH setting and set to 8 hours.
- Select the FLUSH setting and set to 20 seconds and DWELL to 0 seconds.
- Set the Pressure Differential (PD) Gauge to 5 psi.
- The PD delay is the interval from the time the PD sends a signal to start a backflush cycle and the time backflush actually starts. This delay insures that the filters are truly dirty before backflush is initiated. The PD delay is fixed at 30 seconds.
- When the PD is activated, display shows I/PD (Idle with PD) and PD LED is on. When three consecutive backflushes triggered by the PD are completed, the alarm output comes on and the display flashes PD ALARM. To reset alarm, press button for one second while controller is in IDLE.
- There is a three digit backflush counter on the display. To reset the count, press the COUNTER RESET button for one second while in IDLE.
- The PERIODIC time resets itself after every cycle. To start the manual backflush, push the MANUAL START button for one second.

# System Maintenance

## General Requirements and Maintenance:

- Confirm there is 30 psi of pressure upstream of the filter during backflush.
- Check that the Pressure Differential (PD) Gauge returns to 0-2 psi after a backflush.
- All vent tubes need to vent freely to atmosphere without any back pressure.
- Drain manifold requirements: 2" pipe, no longer than 30' in length without elevating.
- To minimize damage to the backflush controller, always keep the door closed and turn off the power when not using the controller for long periods of time.

## Seasonal Maintenance:

- For DC Latching Backflush Controller, replace two 9 Volt lithium batteries every two-three years, or as needed. Batteries are located inside the backflush controller.
- At the end of the irrigation season, just before shutdown, initiate a backflush with the required pressure and turn off the water. This will ensure the discs remain clean during the offseason.
- Manually clean the discs if needed – see detailed instructions on Page 9.
- Clean the finger filter - see location in diagram on Page 14.
- In order to prevent the filter from becoming damaged under freezing conditions, drain all the water from the filter and disconnect the control tubes making sure to label for correct reattachment.

### Monthly Check

<input checked="" type="checkbox"/>	Inlet/Outlet Pressure
<input checked="" type="checkbox"/>	Backflush Controller
<input checked="" type="checkbox"/>	Leakage
<input checked="" type="checkbox"/>	Solenoid
<input checked="" type="checkbox"/>	Downstream Pressure and Drain

## Bypass Filter Maintenance:

- Close the inlet water after backflushing the system and make certain there is no pressure in the system.
- Use a wrench to release tightening nuts – see **1** and **2**.
- Unscrew the nut completely – see **3**.
- Twist the bypass filter – see **4**.
- Remove the internal screen element and rinse the screen element – see **5**.
- Reassemble.
- Open the inlet valve.

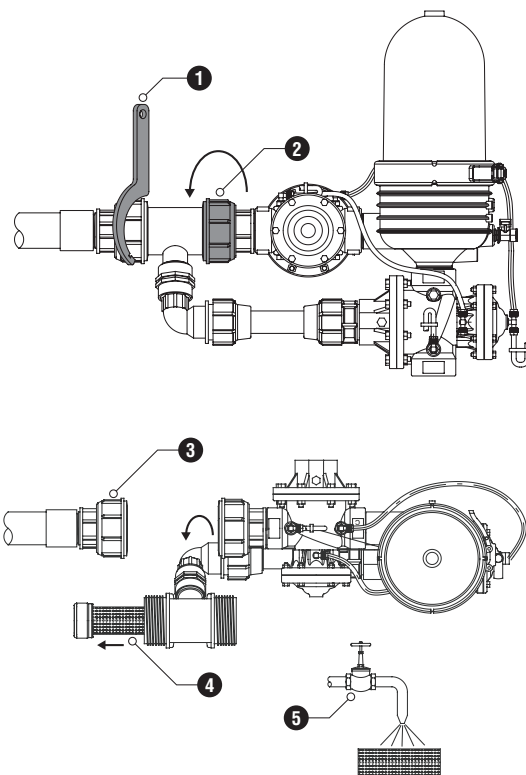

# System Maintenance

## Disc Cleaning Instructions:

**NOTE:** Make sure the system is not under pressure.

- Release the clamp and remove the cover (Figure 1).
- Unscrew the butterfly-nut on the filtration element (Figure 2).
- Remove the tightening cylinder (Figure 3).
- Remove the discs. For convenience, we recommend using a plastic bag (Figure 4, 5).
- Tie each disc set on a string and place them in a cleaning solution. Refer to instructions on Page 10 for recommended cleaning solutions based on water deposits.
- Thoroughly wash the discs with fresh water and then reassemble the discs on the spine (Figure 6).
- Check that the correct quantity of discs is assembled on the spine. When the discs are pressed with two hands, the top disc should be centered between the two lines molded in the plastic at the top of the nozzles (Figure 7).
- Replace the tightening cylinder and tighten the butterfly nut until it stops - do not overtighten (Figure 8, 9).
- Reassemble the filter cover and tighten the clamp (Figure 10, 11).

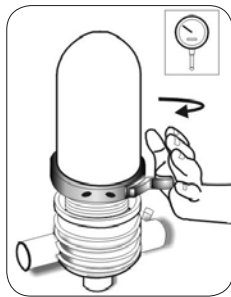

Figure 1

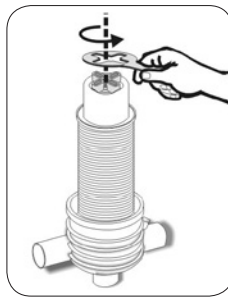

Figure 2

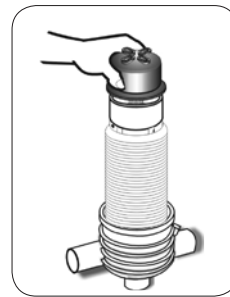

Figure 3

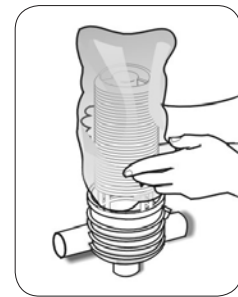

Figure 4

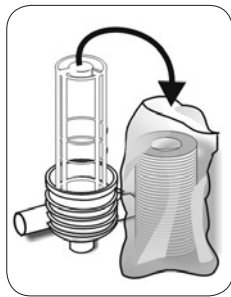

Figure 5

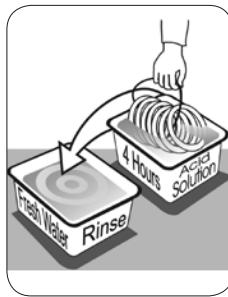

Figure 6

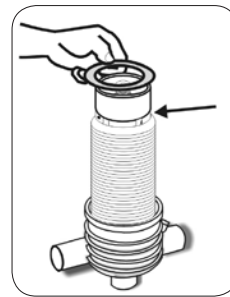

Figure 7

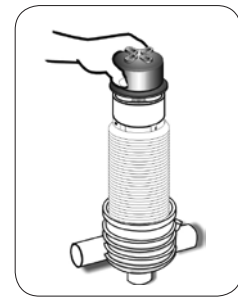

Figure 8

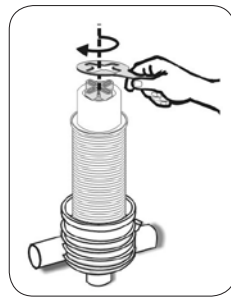

Figure 9

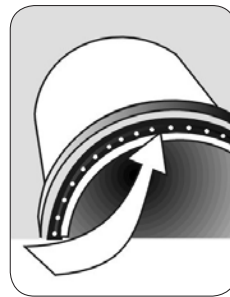

Figure 10

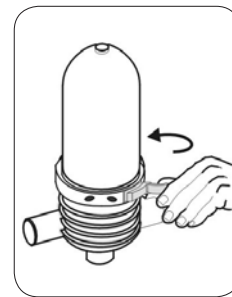

Figure 11

# System Maintenance

## Disc Cleaning Instructions for Surface Water with Organic and Biological Residue:

### Step 1

- Make a 10% Peroxide solution. Pour 1.8 gallons of water into a container and add .80 gallons of Hydrogen Peroxide (35%) or pour 2.1 gallons of water into the container and add .53 gallons of Hydrogen Peroxide (50%) to the water.
- Soak the discs in this solution making sure the discs are loose and have good contact on both sides with the Peroxide solution. Do not put too many discs in at one time.
- Stir the discs in the solution a few times.
- Total soaking time is 1 to 3 hours. If the solution is no longer cleaning the discs, replace it with a new mixture.
- Remove the discs and rinse well with water – there should only be a pale sedimentation on the discs.

### Step 2

- After the discs have been rinsed with water, they must be soaked in a 10% Hydrochloric Acid solution to remove the organic residue.
- Make a 10% Hydrochloric Acid solution. Pour 1.8 gallons of water into a container and add .80 gallons Hydrochloric Acid (30-35%) to the water.
- Soak the discs in this solution making sure the discs are loose and have good contact on both sides with the acid solution. Do not put too many discs in at one time.
- Stir the discs in the solution a few times.
- Total soaking time is 1 to 3 hours. If the solution is no longer cleaning the discs, replace it with a new mixture.
- Remove the discs and rinse well with water – there should no longer be any residue between the grooves of the discs.
- Put the discs on the spine and spine assembly in the filter bank.
- Flush the filter bank a few times to remove all chemicals.

## Disc Cleaning Instructions for Well Water with Manganese, Iron or Carbonate Deposits:

### Step 1

- Make a 10% Hydrochloric Acid solution. Pour 1.8 gallons of water into a container and add .80 gallons Hydrochloric Acid (30-35%) to the water.
- Soak the discs in this solution making sure the discs are loose and have good contact on both sides with the acid solution. Do not put too many discs in at one time.
- Stir the discs in the solution a few times.
- Total soaking time is 1 to 3 hours. If the solution is no longer cleaning the discs, replace it with a new mixture.
- Remove the discs and rinse well with water – there should only be a pale sedimentation on the discs.

### Step 2

- After the discs have been rinsed with water, they must be soaked in a 10% Peroxide solution to remove the organic residue.
- Make a 10% Peroxide solution. Pour 1.8 gallons of water into a container and add .80 gallons of Hydrogen Peroxide (35%) or pour 2.1 gallons of water into the container and add .53 gallons of Hydrogen Peroxide (50%) to the water.
- Soak the discs in this solution making sure the discs are loose and have good contact on both sides with the Peroxide solution. Do not put too many discs in at one time.
- Stir the discs in the solution a few times.
- Total soaking time is 1 to 3 hours. If the solution is no longer cleaning the discs, replace it with a new mixture.
- Remove the discs and rinse well with water – there should no longer be any residue between the grooves of the discs.
- Put the discs on the spine and spine assembly in the filter bank.
- Flush the filter bank a few times to remove all chemicals.

**Caution:** When blowing out with compressed air, make sure all parts are opened.

# Troubleshooting

## Troubleshooting for No Backflush Operation

If the filter is not backflushing, it could be one or more of the following reasons:

1. The Diverter Screen is Dirty
2. The Backflush Controller is Not Working
3. The Pressure Differential (PD) Gauge is Not Working
4. The Solenoid is Not Working
5. The Backflush Valve is Not Working Properly

### 1. The Diverter Screen is Dirty:

The diverter filter screen is a small cylindrical screen located near the inlet of the filter between the two large unions. This screen only filters water when the filter starts to flush.

- Initiate a backflush by turning the manual override of the DC latching solenoid 90 degrees to the left or by turning the brass knob of the AC solenoid brass base 90 degrees.
- If the filter flushes, the diverter filter screen is clean and the problem is elsewhere.
- If the filter does not flush, the diverter filter screen may be dirty.
- If this screen becomes clogged, there is no command water available to clean the discs.
- To clean the diverter filter screen:
  - Unscrew both unions completely.
  - Push the section between the unions forward.
  - Pull out the screen from its housing and clean with water pressure.
  - Return the screen to its housing. Make sure the screen is completely inserted with the o-rings in place.
  - Re-align the screen housing and tighten the unions by hand only.
- Flush the filter again via the manual override. The filter should flush and will continue to flush until the manual override is returned to its automatic position.

### 2. The Backflush Controller is Not Working:

- To test the backflush controller, initiate a backflush by pressing the black button (manual override) on the front of the panel. If a backflush was initiated, then the controller panel, batteries and solenoid are good. If the backflush did not work, we need to determine which component is not working.
- For DC Latching backflush controllers, make sure the batteries are charged. Batteries should be changed every 2-3 years depending upon frequency of filter irrigation and flushing. Use two 9 volt DC Lithium Batteries only.
- For AC backflush controllers, make sure the transformer is still functioning and replace if needed.
- Check the incoming current to the controller. It should read 110 volt for AC models and 10 to 20 volts for DC models.
- Check the incoming current to the controller panel. For AC models (after the transformer), it should read 24 volts.
- Check the outgoing current from the panel. For AC models, current should be 24-27 volts. For DC models, current should be 12-14 volts.
- The controller panel can malfunction if exposed to moist or dusty conditions, rust, or lightning. If you suspect any of these causes, contact the backflush controller manufacturer for inspection and possible warranty or repair. Or call Netafim USA Technical Support at 888-638-2346 for assistance.

## Troubleshooting for No Backflush Operation, *continued*

### 3. The Pressure Differential (PD) Gauge is Not Working:

- The PD gauge is installed just below the backflush controller and the short needle should be set to 5 psi.
- Turn the black knob of the PD gauge carefully to adjust the setting.
- The long red needle indicates the pressure differential at any given time. If the needle reads zero, then the discs are clean. As the red needle moves towards the shorter (set point) needle, then the discs are getting dirty. When the two needles touch, the backflush controller will initiate a flush cycle.
- To test the PD gauge, while the water is on, disconnect the hydraulic tube from the low pressure port of the gauge (the off center port). Water will squirt out of the tube; you can bend the tube to temporarily stop the water. The long red needle should move and touch the short needle and start a flush cycle. After the programmed delay, if the flush starts then the PD gauge is working. If there is no flush, replace the PD gauge.
- Re-connect the hydraulic tube to the PD gauge.

### 4. The Solenoid is Not Working:

- If the backflush controller is working, press the manual override button on the controller. The solenoid should click and send the filter into flush mode. After 20 seconds, the solenoid should click again and end the backflush.
  - If it doesn't click, replace the solenoid.
- If you are not sure the backflush controller is working, test the solenoids:
  - Remove the wires of the solenoid from the terminal of the control panel and connect them directly to the power source.
  - For DC models, touch the wires to the battery terminals.
  - For AC models, connect the solenoid wires to the outlet transformer wires.
  - If the solenoid clicks, then the solenoid is operating and the control panel is not. If the solenoid does not click, then the solenoid needs to be replaced.

### 5. The Backflush Valves are Not Working:

- If all other components are functioning and the filter is not flushing, the backflush valves may not be working.
- Remove the valve cover. Do not unscrew the bolts connecting the bonnet to the valve body. Rather, disconnect all hydraulic tubes to the solenoid and valve, grasp the bonnet of the valve with both hands and unscrew the entire bonnet assembly from the valve base. Lift the bonnet and stem assembly from the valve body and inspect the parts.
- Replace any faulty valve parts.

# Troubleshooting

## Troubleshooting for Continuous Backflushing

If the filter is constantly backflushing, it could be one of the following reasons:

1. Filter Discs are Extremely Dirty or Clogged
2. Filter is Flushing With Less Than 30 psi
3. Drain Manifold is Too Long or Becomes Too Elevated
4. Defective Pressure Differential (PD) Gauge
5. Solenoid Wires May Be Connected Incorrectly

### 1. Filter Discs are Extremely Dirty or Clogged:

- Turn off the water and be sure there is no pressure in the system.
- Drain the filter by opening the small ball valve on the filter body.
- Open the clamp on the filter and remove the cover.
- If the discs are extremely dirty, open the butterfly nut on top of the spine and remove the discs. Clean according to the instructions on Page 9.
- Return the discs to the spine making sure the height of the discs (when compressed with your fingers) is in between the two lines indicated on the plastic at the top of the nozzles.
- Return the cap and butterfly nut and very snugly tighten the nut (do not over tighten) with the Netafim butterfly wrench.

### 2. Filter is Flushing With Less Than 40 psi:

- Check the upstream pressure gauge during the flush mode. If the gauge reads less than 30 psi, then the discs will not clean properly.
- Increase the pressure to a minimum of 30 psi.

### 3. Drain Manifold is Too Long or Becomes Too Elevated:

- The drain manifold must be a 2" diameter pipe, not longer than 30 feet and not elevating.
- If the drain manifold elevates, every 2.3 feet equals one (1) psi.  
Example: With a 10 foot elevation, an additional 4.4 psi must be added to the required minimum flushing pressure of 30 psi. The new required flushing pressure becomes 35 psi.

### 4. Defective Pressure Differential (PD) Gauge:

- If the needles of the PD gauge are stuck together all of the time, the gauge is broken and needs to be replaced.
- Test the PD gauge by following the directions in "The Pressure Differential Gauge (PD) Gauge is Not Working" section on Page 12.

### 5. Solenoid Wires May Be Connected Incorrectly:

- Make sure the red solenoid wire is connected to the (-) solenoid terminal marked S1. Make sure the black wire is connected to the (+) solenoid terminal marked S1.



# Replacement Parts

## 2" Compact Disc-Kleen Filter Parts

Key	Item Number	Model Number	Description
18	70620-002302	25AP25016220	Filter Cover (Grey)
19	70620-003900	25AP50050002	Hydraulic Seal
20	70620-004700	25AP50420030	Clamp
21	70620-007403	25AP21991002LC	Spine Complete Without Rings
	70620-007412	25AP21991008LC6	Spine Complete Without Rings for Low Flow
21.1	70620-006010	25AP25066224G	Green Butterfly Nut
21.2	70620-007390	25AP25060226	Tightening Cylinder
21.3	70620-006452	25AP25300217	White Piston
21.4	70620-004106	25AP50032115	O-Ring
21.5	70620-001410	25AP49-080S	Ring Set Only - Yellow, 80 Mesh
	70620-001420	25AP49-120S	Ring Set Only - Red, 120 Mesh
	70620-001430	25AP49-140S	Ring Set Only - Black, 140 Mesh
21.6	70620-005850	25AP50760009	Abrasion Shield ( <i>High Flow Model Only</i> )
21.7	70620-007050	25AP50060008	Cone Membrane
22	70620-006050	25AP22340324	Complex Adapter
22.1	70620-004150	25AP50032234	O-Ring 2-234
23	70620-003286	25AP22002206	Body - threaded connection (Grey)
24	70620-007900	25AP50760028	Butterly Nut Wrench
25	70620-008000	25AP50760019	Spine Wrench

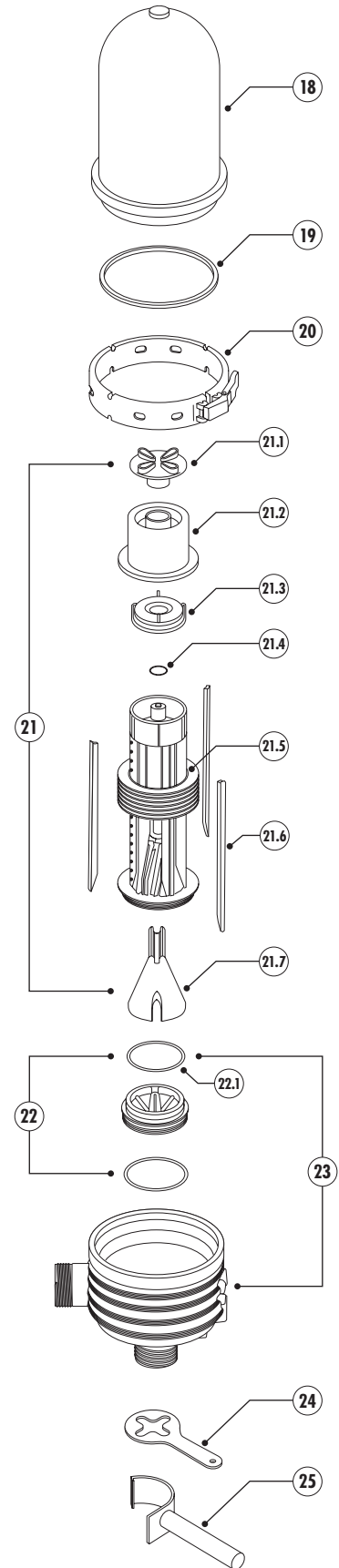



**NETAFIM USA**  
5470 E. HOME AVE.  
FRESNO, CA 93727  
CS 888 638 2346  
F 800 695 4753

[www.netafimusa.com](http://www.netafimusa.com)

A056 5/10