

FILTRATION

HYDROCYCLONE SAND SEPARATORS

OPERATION, INSTALLATION & MAINTENANCE GUIDE



**HYDROCYCLONE &
SEDIMENTATION TANK**

DESCRIPTION

A Hydrocyclone separates sand and other solid matter from water with very little head loss and 90% or better efficiency. There is no head loss build up and no clogging when the solids are separated. Hydrocyclones are easy to operate and maintain, and have no moving parts or screens.

Versatility in system configurations and ease of installation are some of its great advantages.

A Hydrocyclone uses a tangential injection flow process, enhancing the centrifugal forces and moving solid particles outwards. The dispersed particles move downward in a spiral path into an underflow chamber (sedimentation tank) while clean liquid moves upwards to the center of the spiral, towards the top outlet.

A specially designed rubber insert protects the neck of the Hydrocyclone from erosion and increases separation efficiency. The Sedimentation Tank can be drained automatically with an automatic flushing kit (an electric valve, controller and small command filter). Automatic flushing will not interfere with the proper functioning of the Hydrocyclone. The Hydrocyclone has a 100 micron protective coating of extra durable polyester applied electrostatically and oven cured on a zinc-phosphate layer for maximal anti-corrosion protection.

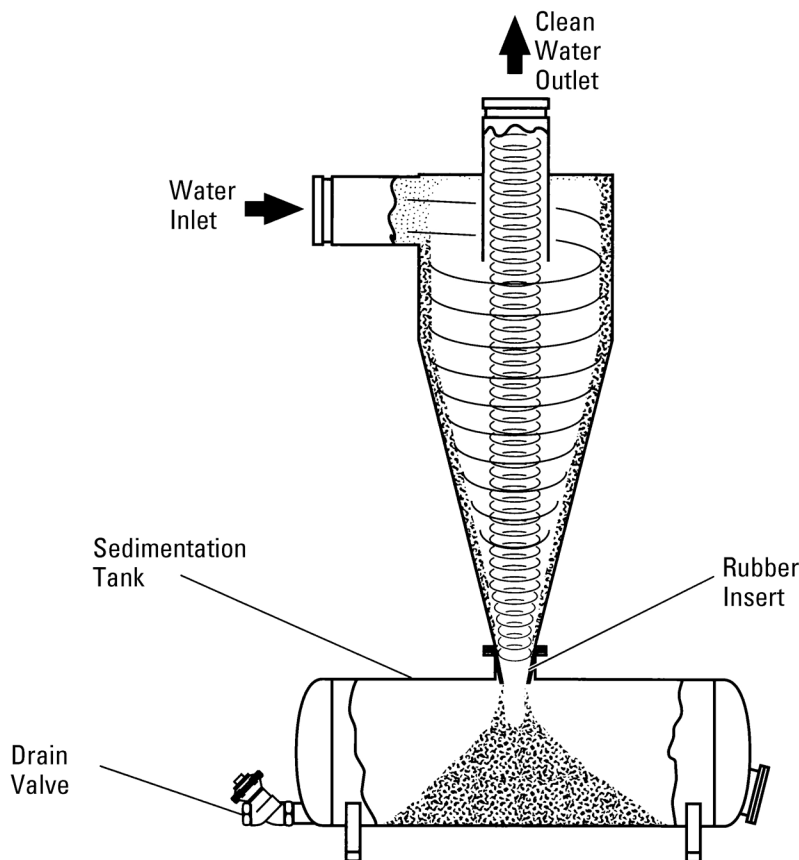

Hydrocyclone Flow and Mode of Separation

SPECIFICATIONS

As a rule, the separation efficiency improves as the Hydrocyclone diameter decreases and the head loss increases. Miniature Hydrocyclones may be used for easy sampling of liquids, for determining filter (including larger Hydrocyclones) operation and efficiency and for testing the feasibility of operation for the problem at hand.

Each filter is designed and manufactured in order to achieve the highest standard of quality and finish.

- Recommended head loss for effective operation: 3-8 psi
- Maximum recommended working pressure: 120 psi
- Maximum pressure: 150 psi
- Water inlet and outlet: horizontal and vertical
- Inserts: standard on all sizes except 3" and 4"
- Protective coating: polyester on zinc-phosphate layer
- Pressure relief valve: must be inserted before the filtering installation if pressure is not controlled
- Available sizes: 3", 4", 6", 8", 12", 16", 20", 24" and 30"
- End connections: Thread (TH), Flange (FL), Groove (GR)
- Sedimentation Tank connections:
 - Thread: 3" and 4" sizes
 - Flange: 12", 16", 20", 24" and 30" sizes
 - Groove: 6" and 8" sizes

RECOMMENDED FLOW RATES

MODEL	INLET/OUTLET DIAMETERS (IN)	HYDROCYCLONE FLOW RANGE (GPM)	STANDARD SEDIMENTATION TANK CAPACITY (GAL)
24HC3	¾ TH	9 - 15	0.5
24HC4	1 TH	15 - 33	0.5
24HC6	1½ TH	33 - 53	2.6
24HC8V	2 GR	48 - 75	2.6
24HC8HV	3 GR	80 - 150	2.6
24HC12F6	4 IN & 3 OUT FL	150 - 230	16
24HC16F6	4 FL	230 - 360	32
24HC20F8	6 FL	430 - 700	58
24HC24F8	6 FL	615 - 1,000	58
24HC30F8	8 FL	1,000 - 1,600	85

OPERATION

Based on the centrifuge principle, the particles are spun against the outside wall of the Hydrocyclone and gravitate towards the bottom into the Sedimentation Tank. The velocity at which the water flows through the Hydrocyclone determines the efficiency at which the particles are separated from the water.

- Normal working conditions are achieved when headloss on the Hydrocyclone is not less than 3 psi with a recommended range of 3-8 psi.
 - A headloss of less than 3 psi will reduce the separation efficiency and a headloss of more than 8 psi might induce increased erosion.
- The Hydrocyclone is designed for a maximum recommended working pressure of 120 psi and should not exceed 150 psi.

INSTALLATION

- Install and connect the Hydrocyclone vertically with the Sedimentation Tank underneath the Hydrocyclone.
- Special attention must be given to the correct flow direction: horizontal inlet and top vertical outlet are clearly marked by arrows.
- Install the manual ball valve to the flush port of the Sedimentation Tank.
- Check that the actual flow rate through the Hydrocyclone is within the recommended range. Inadequate flow rate will result in reduced performance.
- If more than one Hydrocyclone is installed, leave sufficient space between units to facilitate maintenance.
- Specially designed manifolds are available for mounting multiple filters.
- A pressure relief valve must be installed upstream of the Hydrocyclone if the pressure is not controlled effectively.

INSTALLATION WITH OPTIONAL AUTOMATIC FLUSHING KIT

- Automatic Flushing Kit includes an electric valve, controller and small command filter.
- Install the electric valve on the outlet opening of the Sedimentation Tank.
- Connect the controller to the electric valve.
- Insert the batteries inside the controller (or plug in for AC) and close the cover tightly.
- Adjust the controller as follows:
 - Flushing time for Sedimentation Tanks with 1.3-16 gallons: 15-20 seconds
 - Flushing time for Sedimentation Tanks with 32-85 gallons: 30-40 seconds
 - Time between flushings: 30-120 minutes
 - If the water contains high loads of dirt, shorten the time between flushings.

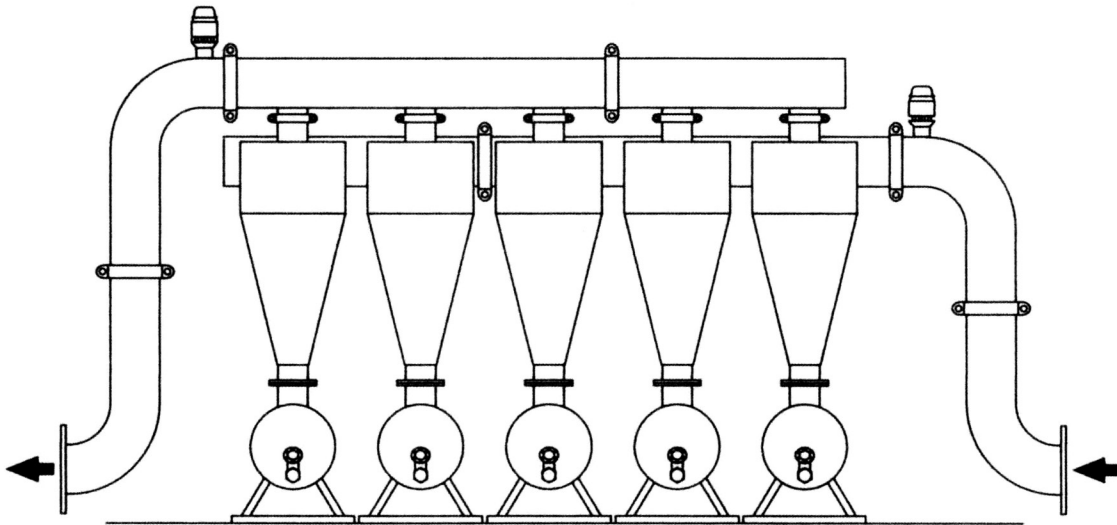

Multiple Hydrocyclone and Sedimentation Tank Installation

SEDIMENTATION TANK FLUSHING

- The Sedimentation Tank can be flushed manually or automatically with an irrigation controller or computer at periodic intervals.
- When a manual valve is installed, drain the Sedimentation Tank at periodic intervals according to the recommendations.
- The Sedimentation Tank should be drained when it is $\frac{1}{3}$ full.
- Do not let the Sedimentation Tank get filled more than $\frac{1}{2}$ of its volume, otherwise the sand will not flush properly. As a result, the sand will spin, have no place to drain, and cause pin holes in the neck of the Hydrocyclone.

SEDIMENTATION TANK PERIODIC CLEANING

- Check that the rubber insert is not worn or damaged and replace if necessary. When separating sand, the rubber insert may need to be replaced every 2-3 years. When separating silt, the rubber insert may need to be replaced every year.
- Close the valve at the inlet of the Hydrocyclone.
- Open the drain valve located at the bottom of the Sedimentation Tank to release pressure and drain.
- Take off the cover.
- Remove all the sediments collected in the Sedimentation Tank.
- Thoroughly rinse the inside of the empty Sedimentation Tank.
- Replace the cover on the Sedimentation Tank so that the cover gasket fits over it.
- Mount tightening bracket and tightening handle properly.

WARNING: Do not tighten or open cover during operation or under pressure.

MAINTENANCE

- Apply a layer of grease to handle threads once a year.
- Immediately repair any damage to the tank's protective coating.

TECHNICAL DATA

HYDROCYCLONE MICRON/MESH

MESH	120	140	180	200	270	325	600
MICRON	130	105	90	75	53	44	25

HEADLOSS

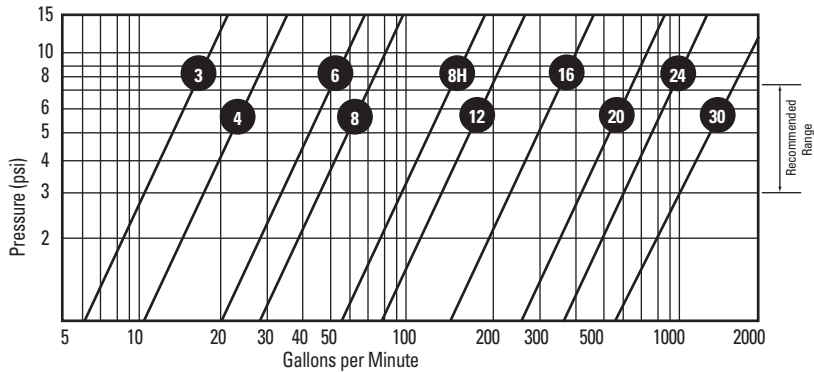

HYDROCYCLONE

(Particle size separation in Micron)

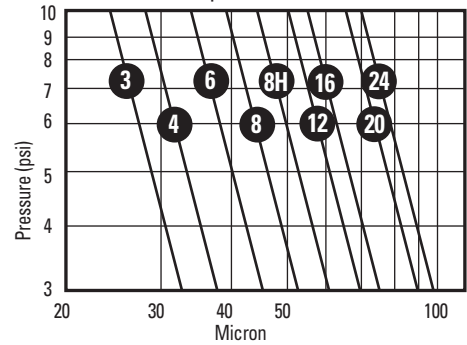

DIMENSIONS & WEIGHT

MODEL	B (IN)	D (IN)	H (IN)	H1 (IN)	H2 (IN)	L (IN)	T (IN)	WEIGHT (LBS)	WEIGHT W/SEDIMENTATION TANK (LBS)
24HC3	¾	3	16**	12.6	11.2	4.7	1.2	18	31
24HC4	1	4	18**	15	13.6	5.5	1.6	20	44
24HC6V	1½	6	26**	20.3	16.7	9.5	2.4	40	76
24HC8V	2	8	29**	22.6	20.9	11.6	3.2	44	80
24HC8HV	3	8	33**	26	24.6	11.8	2.6	60	96
24HC12F6	4 IN & 3 OUT	12	52	44.5	28.5	19.7	4.1	146	221
24HC16F6	4	16	68	58.3	38.2	23.6	5.7	276	420
24HC20F8	6	20	75	63.4	45.3	23.6	6.7	379	571
24HC24F8	6	24	85	73.2	55.3	23.6	8.7	452	644
24HC30F8	8	30	111	93	75.8	27.6	10.4	770	962

** Height for sedimentation tank without legs

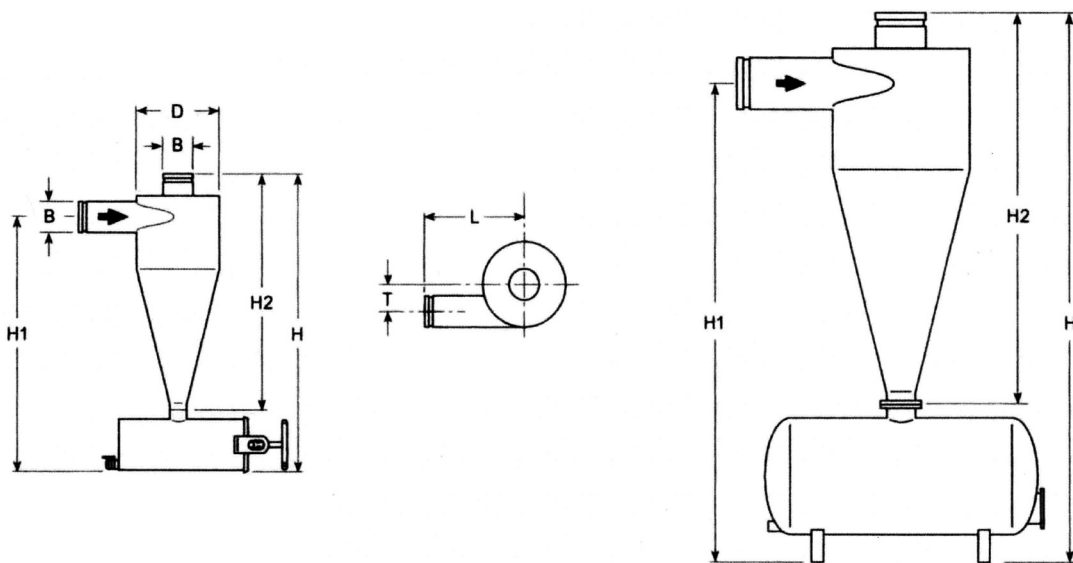

REPLACEMENT PARTS

HYDROCYCLONE & SEDIMENTATION TANK PARTS

KEY	ITEM NUMBER	MODEL NUMBER	DESCRIPTION	USED WITH SEDIMENTATION TANK OR HYDROCYCLONE MODEL NUMBER
1	70020-007450	44E000101	Handle	24ST002L
	70020-007500	44E000100	Handle	24ST010FLV2
2	70020-007720	44E000214	Tightening Bracket	24ST002L
	70020-007700	44E000216	Tightening Bracket	24ST010FLV2
3	-	44E000240	Side Port Cover	24ST002L
	70020-008000	44E000260	Side Port Cover	24ST010FLV2, 24ST060F6
	70020-007900	44E400260	Side Port Cover	24ST120F6, 24ST220F8
4	70020-008070	44E001340	Side Port Neoprene Cover Gasket	24ST002L
	70020-008350	44E001361	Side Port Neoprene Cover Gasket	24ST010FLV2
	70020-008200	44E004365	Side Port Neoprene Cover Gasket	24ST060F6, 24ST120F6, 24ST220F8
5	70020-015200	24E545950	Rubber Insert	24HC8V, 24HC8HV
	70020-015230	24E550952	Rubber Insert	24HC12F6, 24HC16F6
	70020-015250	24E560952	Rubber Insert	24HC20F8, 24HC24F8, 24HC30F8
-	70021-000730	24HCTESTER	Hydrocyclone Tester Kit	-
-	33500-002100	44Z400409	Hydrocyclone Glass Tube	-
-	70020-016175	44Z209	Hydrocyclone Nut & Washer for Tester Kit	-

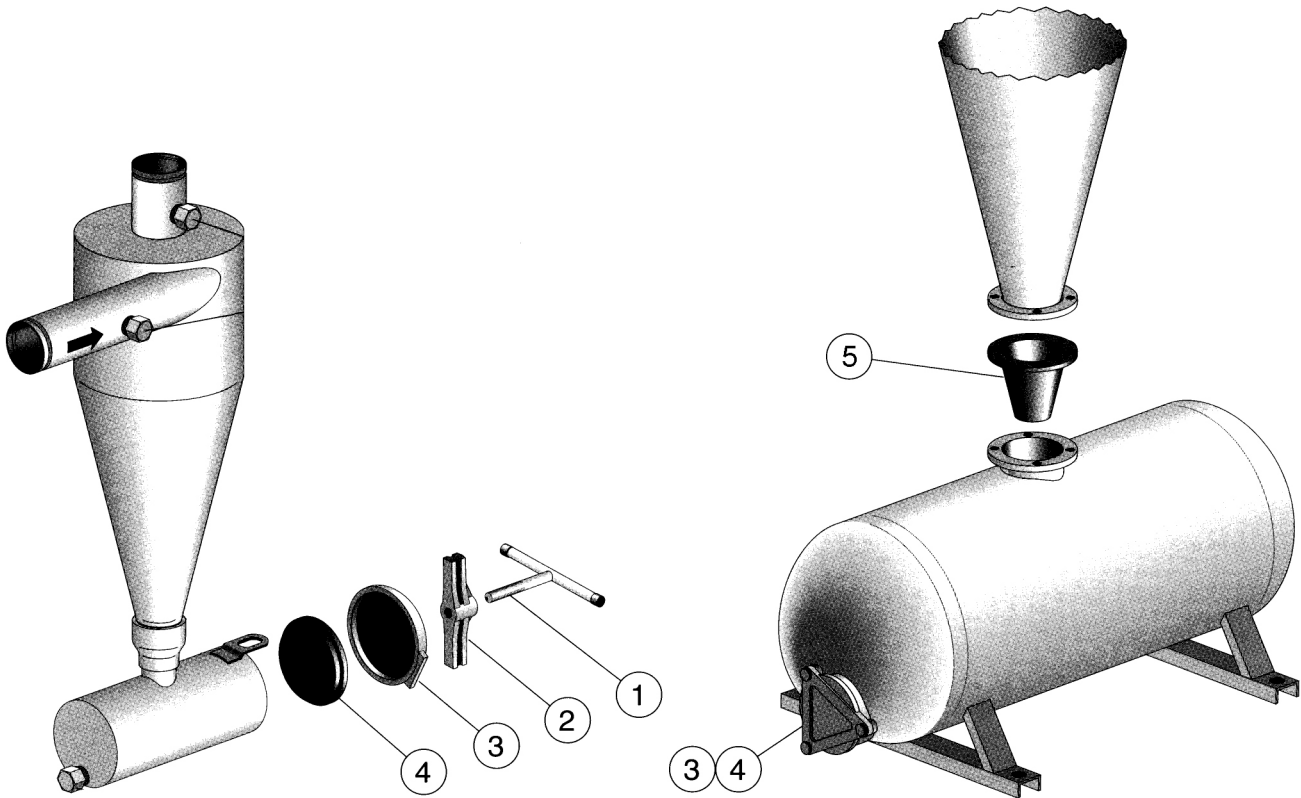



NETAFIM USA
5470 E. Home Ave.
Fresno, CA 93727
CS 888 638 2346
F 800 695 4753
www.netafimusa.com