

N E T A F I M U S A

## Quick Relief (QR) Valves

### SELECTION, INSTALLATION, OPERATION AND TROUBLESHOOTING GUIDE

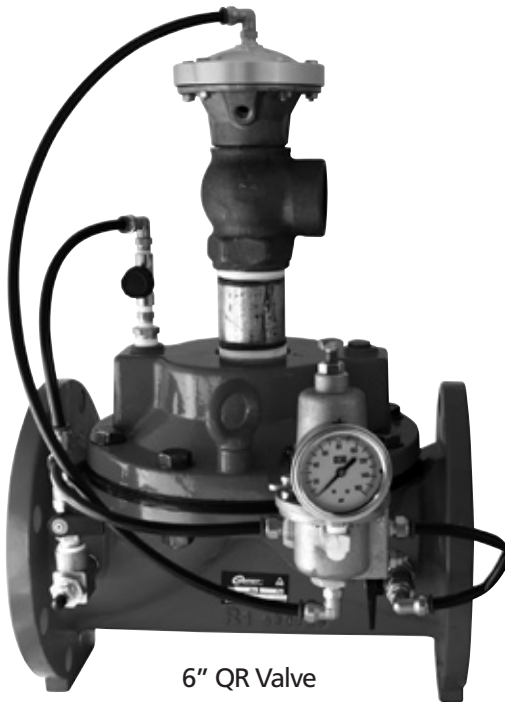

6" QR Valve



2" Angle QR Valve



**NETAFIM USA**  
5470 E. HOME AVE.  
FRESNO, CA 93727  
CS 888 638 2346  
F 800 695 4753  
[www.netafimusa.com](http://www.netafimusa.com)



# Preface

<b>Introduction</b> .....	<b>4</b>
<i>Learn why a QR Valve protects the pump station, filters and pipelines.</i>	
<b>Selection and Ordering Information</b> .....	<b>6</b>
<i>Includes guidelines for selecting the proper QR Valve along with an ordering example and easy to understand ordering charts.</i>	
<b>Headloss Chart</b> .....	<b>8</b>
<i>Technical information for all sizes of Iron and Bronze QR Valves.</i>	
<b>Purchase Specifications</b> .....	<b>8</b>
<b>Components</b> .....	<b>9</b>
<i>A comprehensive listing of all the components in a QR Valve along with illustrations, charts and model numbers.</i>	
<b>Installation, Settings and Maintenance</b>	
<i>A review of installation, settings and adjustment guidelines along with maintenance and winterizing tips and information.</i>	
<b>2" QR Valves</b> .....	<b>12</b>
<b>3" and Larger QR Valves</b> .....	<b>13</b>
<b>Valve Components</b>	
<i>Exploded drawings with components, descriptions, quantities and ordering information.</i>	
<b>2" QR Valves</b> .....	<b>14</b>
<b>3" and 4" QR Valves</b> .....	<b>15</b>
<b>6" and Larger QR Valves</b> .....	<b>16</b>
<b>Troubleshooting</b> .....	<b>17</b>
<i>Basic troubleshooting problems and solutions.</i>	

# Introduction

## QR Valves Protect Pump Station, Filters and Pipelines Cost Effectively

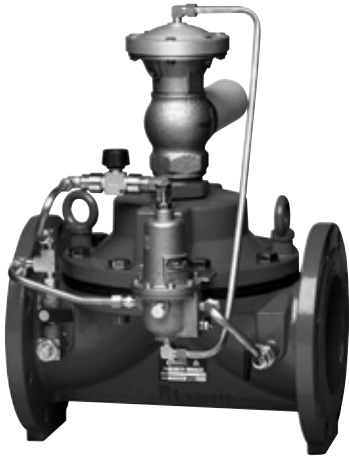

The Netafim USA Quick Relief (QR) Valve is the universal solution for protecting all types of pump stations, filters and pipelines. A QR Valve ensures that a potential pressure rise in the system will not damage the critical components of your irrigation system. This is accomplished by maintaining or continuously “sensing” the pressure in the line upstream of the valve and **quickly** opening the valve and venting the excess pressure from the system. Once the pressure declines and returns to normal, the QR Valve will return **slowly** to its closed position.

### With a Netafim QR Valve you gain:

- More reliability - with a simple design that’s easy to install and maintain
- More flexibility - with an adjustable set point, the valve can be used for a wide range of pressures
- More capacity - with high capacity, a small valve can be used to relieve large amounts of flow

### QR Valve Features

#### Quick Relief Action Ensures Maximum Security

- Large water passages allow the chamber of the valve to vent quickly, providing immediate protection for the system

#### Slow Closure Provides Water Hammer Protection

- The “no slam” design allows the valve to close slowly, reducing the danger of water hammer when the system goes back to normal. Speed of closure is adjustable.

#### Pilot Operated Valve = Flexibility

- The set point of the valve is adjustable allowing the user the flexibility to change the setting if the requirements change. A large pressure range is covered with one spring.
- Straight and angle configurations provide more options for convenient installation.
- Available in threaded, flange or grooved connections.

#### Hydraulic Valve with Direct Sealing Diaphragm Means Longer Functional Life

- No stem, shaft or bearings within the water passage.
- Simple and reliable design with longer life and less maintenance.
- Suitable for dirty water and wastewater.
- Reliable bronze valves are available for high pressure systems.

#### Easy Installation and Low Maintenance

- Netafim valves are the most reliable in the industry and have the longest warranty, resulting in less shutdowns.
- Easy to install and operate.

# Introduction

## QR Valve Operation

A QR Valve is predominantly installed upstream of the filter with a tee out of the mainline. During standard operation, the QR Valve will be normally closed. Pressure in the mainline is being continuously "sensed" by the QR Valve. (See Figure 1).

During an event of pressure surge, such as immediately after pump start-up or a field valve closure, the pilot senses the rise in pressure and the QR Valve quickly opens fully in order to relieve the pressure. The desired pressure for opening is referred to as the "set point" of the valve (See Figure 2).

The valve remains fully open until the pressure drops back to normal. When the pressure returns to normal, the valve closes at an adjustable pace (See Figure 3).

## Filters with QR Valves

Netafim AGF Sand Media Filter tank system with an installed QR Valve and Netafim manifolds has an extended warranty – 5 years instead of the standard 2 years.

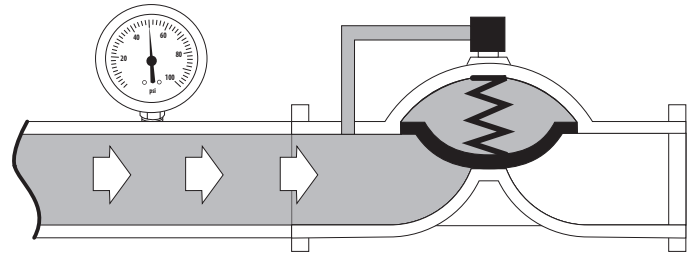

**Figure 1:** QR Valve is fully closed when the pressure is within normal conditions, below the QR valve set point.

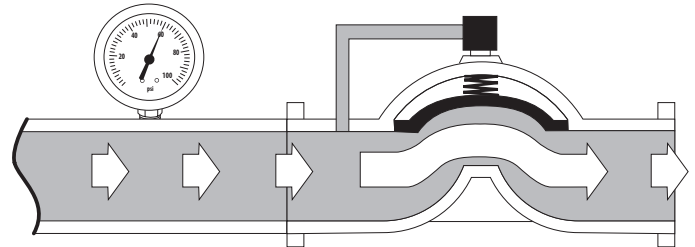

**Figure 2:** QR Valve venting mode – valve fully opens when upstream pressure rises. Usually the QR Valve is set to open when the pressure rises 10 psi above the normal condition (this is an adjustable set point).

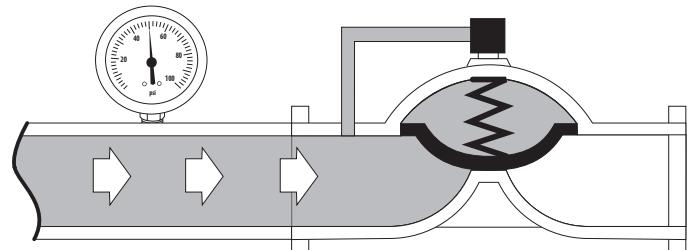

**Figure 3:** QR valve slowly closes as the pressure returns and is fully closed when the QR Valve set point is reached.



**QR Valve** located upstream of a sand media filter.

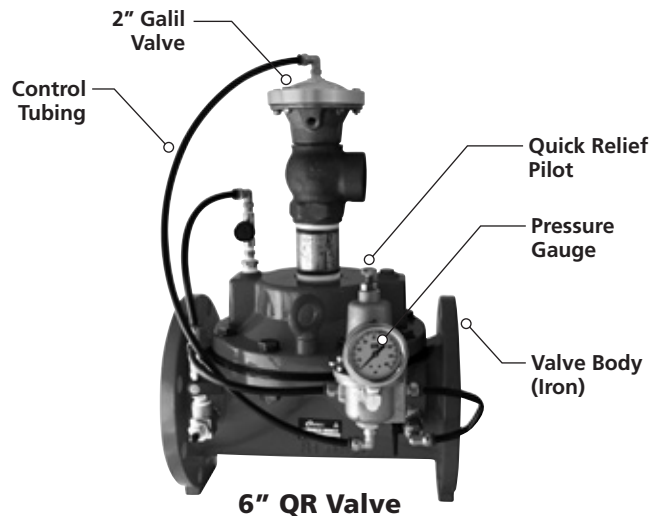

# Selection & Ordering Information

## Selection Guidelines

When selecting a QR Valve, the following recommended maximum flow rates should be considered to ensure proper sizing and performance.

### MAXIMUM RECOMMENDED FLOW RATE

Valve Size →	2"	3"	4"	6"	8"	10"	12"
Flow Rate (GPM)	480	1,080	1,200	4,200	5,760	11,640	16,800

**NOTE:** Sizing a QR Valve differs from sizing a standard inline valve. This is because the QR Valve does not work continuously, but rather only in events of pressure surges. More water is allowed through a valve that will be activated in shorter amounts of time than through an inline valve that will be operational most of its life.

### MAXIMUM WORKING PRESSURE

Material	Valve Size	psi
Iron/Bronze	All	235

## How to Size a QR Valve

**Quick Sizing Formula:** The valve should be sized to match the expected relief flow at the set opening pressure:

$$D[\text{inch}] = \text{SQRT} [0.109 \times \text{Flow (GPM)} / \text{SQRT Pressure (psi)}]$$

$$D = \sqrt{\frac{0.109 \times \text{Flow (GPM)}}{\sqrt{P (\text{psi})}}}$$

## Ordering Example

**Pipeline:** 6"

**Required Flow Rate:** 600 GPM

Valve should be open at 80 psi. First determine the numerator:  $0.109 \times \text{Flow (GPM)} = 0.109 \times 600 \text{ GPM} \approx 60$ . Then determine the denominator: The square root of 80  $\approx 9$ . The square root of  $(60/9) = \text{sqrt}(6.66) = 2.58$

The size of the valve should be the larger immediate size meaning we would recommend a 3" QR valve for this example.

Please note: If we had the same amount of flow, 600 GPM at a pressure of 140 psi, we would still need a 3" QR Valve. Also in this example, if the flow is 800 GPM at 80 psi, we would still need a 3" QR Valve.

Due to the nature of the formula having square roots, the same size valve covers a relatively large range of flows and pressures. Most of the traditional systems will be covered with either a 2" or 3" QR Valve.

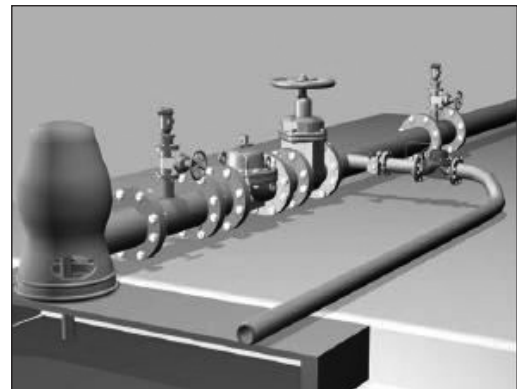

*Typical Installation*

## QRL Valve

A QRL Valve, Quick Relief Low Pressure, also known as a Pressure Sustaining Relief Valve is a variation of the QR Valve.

- Lower in cost since it is standard with a plastic pilot, 61PIL29200, for all valves 4" and smaller.
- Limited to a set point of 90 psi – use a QR Valve for set points higher than 90 psi.
- Usually used as a continuous regulating valve rather than a normally closed valve that opens fully to relieve pressure and will continuously release water.
- Slower reaction time than a QR Valve.
- Does not qualify for the extended warranty when used with Netafim AGF Sand Media Filters.

# Selection & Ordering Information

## ANGLE VALVES

### BRONZE MATERIAL with THREADED CONNECTION

Size	Max. Flow (GPM)	Model Number	Item Number
2"	480	71610-026010	61QR2-AN-G



## ANGLE VALVES

### IRON MATERIAL with THREADED CONNECTION

Size	Max. Flow (GPM)	Model Number	Item Number
2"	480	71610-026130	61QR2IT-AN-G
3"	1,080	71610-026170	61QR3AN-CXPS

## ANGLE VALVES

### IRON MATERIAL with GROOVED CONNECTION

Size	Max. Flow (GPM)	Model Number	Item Number
3"	1,080	-	61QR3IGAN-CXPS

## ANGLE VALVES

### IRON MATERIAL with FLANGED CONNECTION

Size	Max. Flow (GPM)	Model Number	Item Number
4"	1,200	71610-026320	61QR4IFAN-CXPS
6"	4,200	71610-026420	61QR6IFAN-CXPS

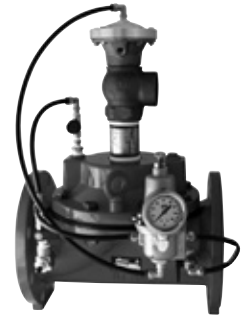

## BRONZE MATERIAL with THREADED CONNECTION

Size	Max. Flow (GPM)	Model Number	Item Number
2"	480	71610-026020	61QR2B-G

## IRON MATERIAL with GROOVED CONNECTION

Size	Max. Flow (GPM)	Model Number	Item Number
2"	480	-	61QR2IG
3"	1,080	-	61QR3IG-CXPS
4"	1,200	71610-026355	61QR4IG-CXPS
6"	4,200	-	61QR6IG-CXPS

## IRON MATERIAL with FLANGED CONNECTION

Size	Max. Flow (GPM)	Model Number	Item Number
3"	1,080	71610-026200	61QR3IF-CXPS
4"	1,200	71610-026300	61QR4IF-CXPS
6"	4,200	71610-026400	61QR6IF-CXPS
8"	5,760	71610-026460	61QR8IF-CXPS
10"	11,640	-	61QR10IF-CXPS
12"	16,800	-	61QR12IF-CXPS

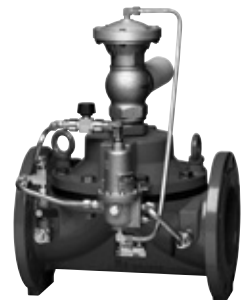

**Note:** For non-standard products, such as QR Valves for pressures above 235 psi call Netafim USA Customer Service. For pricing and ordering information, refer to the Agriculture Division Price List. Call for Item Numbers not listed.

# Headloss Chart

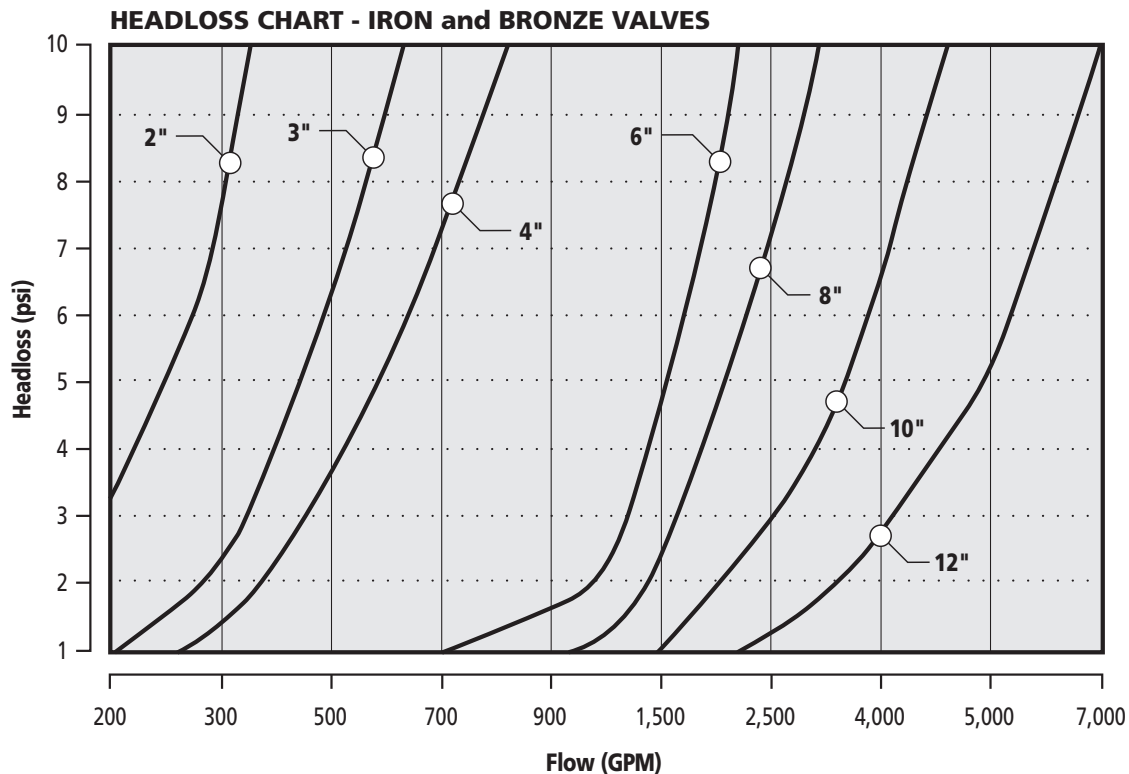

## Purchase Specifications

The valve will be hydraulic, direct sealing diaphragm type, which allows inline maintenance. No stem, shaft or guide bearing will be located within the water passage. The valve will be activated by the line pressure or by an external hydraulic or pneumatic pressure. The valve will be operated by a pressure relief pilot valve for fast opening at a higher pressure set point. The valve and the controls will be a Netafim Iron or Bronze Series 100 valve or similar in all aspects.



QR Angle Valve

# Components

## Quick Relief (QR) Valve Components

A Quick Relief (QR) Valve ships pre-assembled by Netafim USA following strict quality standards.

The QR Valve consists of a Basic Valve, a Quick Relief Pilot and a Needle Valve (some pilots come with an integral needle valve where the needle valve is inside the pilot); Valves 6" and larger use an additional 2" Galil Valve so the chamber of the valve will vent quickly even if the valve is large.

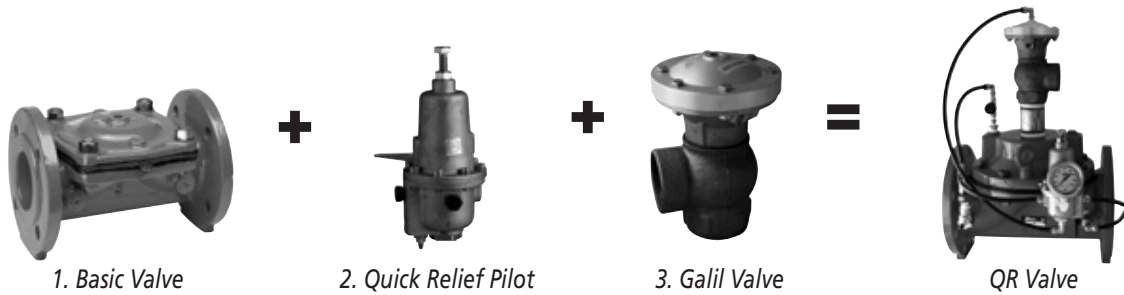

### 1. Basic Valve

The basic valve consists of four simple parts - body, spring, diaphragm and bonnet - making it the simplest valve to operate and maintain. Installation is quick and easy with its unique inline design which also creates low losses at high flow rates.

- Available with two body material options - Iron or Bronze
- Stainless steel internal spring provides strength and long-life
- Flexible reinforced direct sealing rubber diaphragm requires no bearings, guides or internal seals
- Cover and body constructed of corrosion resistant materials

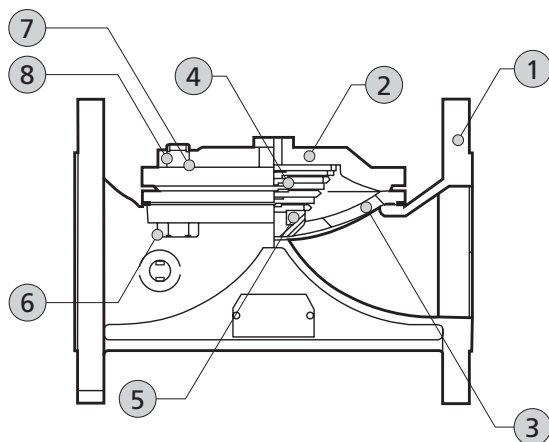
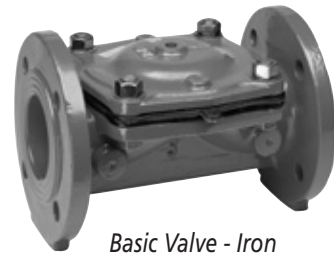

Illustration of a Basic Iron Valve

#### COMPONENTS

Key	Description
1	Body
2	Bonnet
3	Diaphragm
4	Spring
5	Spring Seat
6	Bolt
7	Washer
8	Nut

# Components

## 1. Basic Valve, (con't.)

### a. Diaphragm

Iron and Bronze valves are standard with a direct sealing natural rubber diaphragm. All QR Valves use a standard pressure diaphragm unless otherwise specified. Refer to the chart below for operating pressure ranges. For information about other diaphragm options, call Netafim USA Customer Service.



Standard Pressure Diaphragm

#### STANDARD DIAPHRAGMS

Valve Size	Operating Range (psi)
2"	21 - 230
3" & 4"	17 - 230
6"	21 - 230
8" & 10"	10 - 230

### b. Hydraulic Control Tubing and Fittings

Hydraulic control tubing is used for various connections on the valve and the tubing size is different based on the valve size. Fittings are available in either Plastic or Prestolock Brass based on the valve size and material. Some smaller sized QR Valves use copper tubing.



Hydraulic Control Tubing

#### HYDRAULIC CONTROL TUBING AND FITTINGS

Valve Size	Tubing Material	Tubing Size	Fittings
Bronze 2" Valves	Copper	1/4"	Copper
All Other Sizes	Nylon	3/8"	Prestolock Brass



Prestolock Brass Fittings

# Components

## 2. Pilots

A pilot is a mini-valve which ensures accuracy of the regulated pressure for hydraulic control valves. In QR Valves, when the line pressure is lower than the pilot's spring setting (the set point), the pilot permits the passage of water into the chamber of the main valve, closing the valve. QR Valves use a CX Brass Pilot with a built-in needle valve and one spring with a pressure range of 20 - 320 psi. The factory setting set point for the CX Brass Pilot is 70 psi. The 2" Bronze QR Valve uses a 68200 Pilot with a green spring and a factory setting set point of 45 psi.

### PILOT SPECIFICATIONS

Valve Size →	2" Bronze	All Other Sizes
Port Size	1/8"	1/2"
Pilot Configuration	2-Way	2-Way
Pilot Pressure Range	14 to 140 psi	20 to 320 psi
Maximum Pressure	235 psi	350 psi
Body/Bonnet Material	Bronze	Bronze
Plunger Material	Stainless Steel	Stainless Steel
Diaphragm Material	Natural Rubber	Natural Rubber
O-Rings Material	Nitrile	Nitrile



*CXPS Pilot*



*68200 Pilot*

### PILOT ORDERING INFORMATION

Valve Size →	2" Bronze	All Other Sizes
Item Number	71610-001320	71610-001265
Model Number	61PIL68200-G	61PILCXPS

## 3. Galil 2" Valve

A 2" Galil Valve is installed standard on QR Valves that are 6" and larger to allow very large flow passages and create the required faster reaction time. The pilot will allow pressure to go out of the chamber of the Galil Valve which will change position and allow the main QR Valve to vent.

### GALIL VALVE ORDERING INFORMATION

Item Number	Model Number
71610-001810	61B2THFSNO



*Galil 2" Valve*

# Installation, Settings & Maintenance

## 2" QR Valves

### Installation Guidelines

1. The valve is installed on a tee-junction in the pipe network.
2. The discharge side of the valve is usually kept in a horizontal position.
3. A manual valve should be installed upstream of the valve to isolate the valve from the network.
4. Do not connect a pipe downstream of this valve unless sized correctly (70% of normal flow).
5. Finger filter is installed at the upstream side of the valve.
6. Use five layers of teflon tape.

### Settings and Adjustment Guidelines

- Tighten the adjustment bolt of the pilot.
- Operate the system at the maximum expected pressure.
- Loosen the adjustment bolt of the pilot until the valve starts to open, then tighten the bolt about 2 turns. The pilot is now set about 5-10 psi higher than the maximum operating pressure. Tighten the lock nut.
- The non-adjustable needle bolt on the pilot will cause the valve to close slowly.

### Maintenance

1. Keep the valve clear from weeds and dirt.
2. The valve should be activated once a year to ensure proper functioning and to clean the upstream side of possible dirt build up.
3. The proper pressure setting should be checked.
4. The needle valve and finger filter should be cleaned once a year.

### Winterizing

Drain the valve by disconnecting the tubing from the access ports and at any location where water can be trapped.

# Installation, Settings & Maintenance

## 3" and Larger QR Valves

### Installation Guidelines

1. The valve is installed on a tee-junction in the pipe network.
2. A manual valve should be installed upstream of the valve to isolate the valve from the network.
3. Do not connect a pipe downstream of this valve unless sized correctly (70% of normal flow).
4. The arrow on the bonnet should match the flow direction.
5. Finger filter is installed at the upstream side of the valve.
6. Bolts of flanged valves should be tightened in a diagonal sequence.

### Settings and Adjustment Guidelines

- Loosen the lock nut and tighten the adjustment bolt of the pilot.
- Open the ball valves.
- Operate the system at the maximum expected pressure.
- Loosen the adjustment bolt of the pilot until the valve starts to open, then tighten the bolt about 1-2 turns. The pilot is now set 5-10 psi higher than the maximum operating pressure. Tighten the lock nut.
- Open the needle valve 1-2 turns to ensure that the valve will close slowly.

### Maintenance

1. Keep the valve clear from weeds and dirt.
2. The valve should be activated once a year to ensure proper functioning and to clean the upstream side of possible dirt build-up. Readjust the pilot if necessary.
3. Open the needle valve fully and readjust.
4. Clean the finger filter once a year.

### Winterizing

Drain the valve by disconnecting the tubing from the access ports and at any location where water can be trapped.

# 2" QR Valves

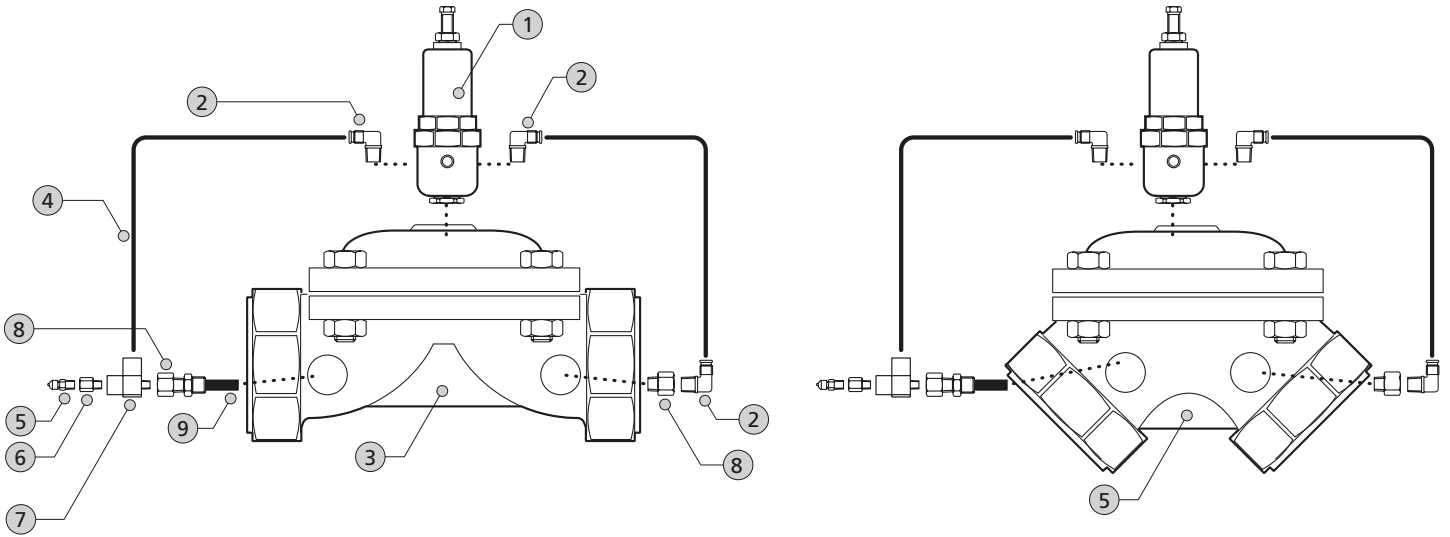

## 2" QR VALVE COMPONENTS

Key	Item Number	Model Number	Qty.	Description
1	71610-001320	61PIL68200-G	1	Brass Pilot 68200
2	78301-001600	55B169PL64	3	Brass Elbow 1/4"
3	-	-	1	Basic Valve Body <i>(based on material and connection)</i>
4	-	-	2	Copper Control Tubing
5	76601-001050	61AP51/8	1	Shrader Valve
6	78301-003300	55B209P42	1	Brass Bushing 1/4" M x 1/8" F
7	78301-002500	55B2225P4	1	Brass Street Tee 1/4"
8	78301-004600	55B222P44	2	Brass Bushing 1/4" M x 1/4" F
9	71680-014000	61SF25SB	1	Brass Finger Filter 1/4" M x 1/4" F

# 3" and 4" QR Valves

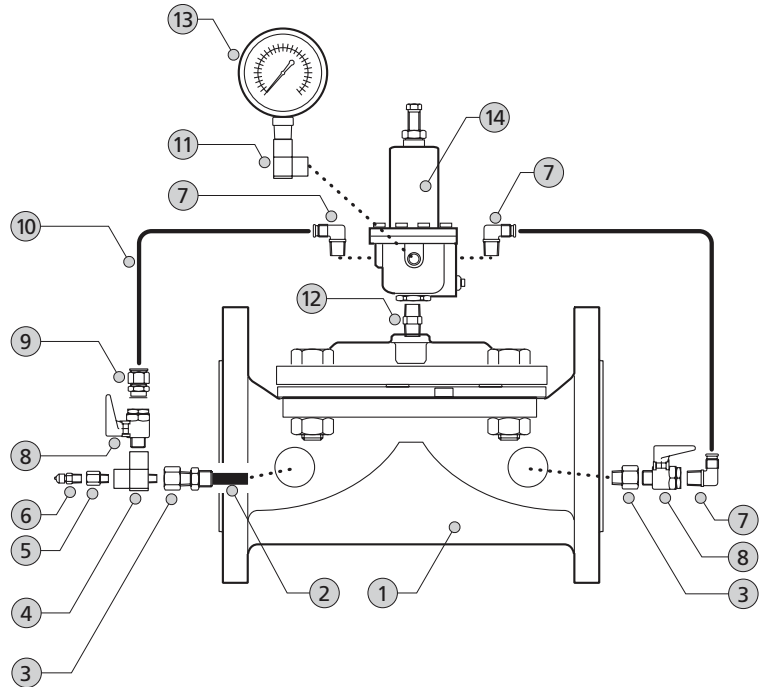

## 3" or 4" QR VALVE COMPONENTS

Key	Item Number	Model Number	Qty.	Description
1	-	-	1	Basic Valve Body <i>(based on size, material, connection)</i>
2	71680-014000	61SF25SB	1	Brass Finger Filter 1/4" M x 1/4" F
3	78301-004600	55B222P44	2	Brass Bushing 1/4" M x 1/4" F
4	78301-002500	55B2225P4	1	Brass Street Tee 1/4"
5	78301-003300	55B209P42	1	Brass Bushing 1/4" M x 1/8" F
6	76601-001050	61APS1/8	1	Shrader Valve
7	78301-001600	55B169PL64	3	Brass Elbow 1/4"
8	71610-035600	62SBV25	2	Brass Ball Valve 1/4"
9	78301-005600	55B68PL64	1	Brass Connector 1/4"
10	71680-018460	55BNB6050	2	Nylon Tubing 3/8"
11	78301-002000	55B2202P44	1	Brass Street Elbow 1/4" F x 1/4" M
12	78301-003900	55B216P4	1	Brass Hex Nipple 1/4"
13	00110-001790	6809020-100	1	Pressure Gauge 0-100 psi
14	71680-001265	61PILCXPS	1	Brass Pilot CXPS

# 6" and Larger QR Valves

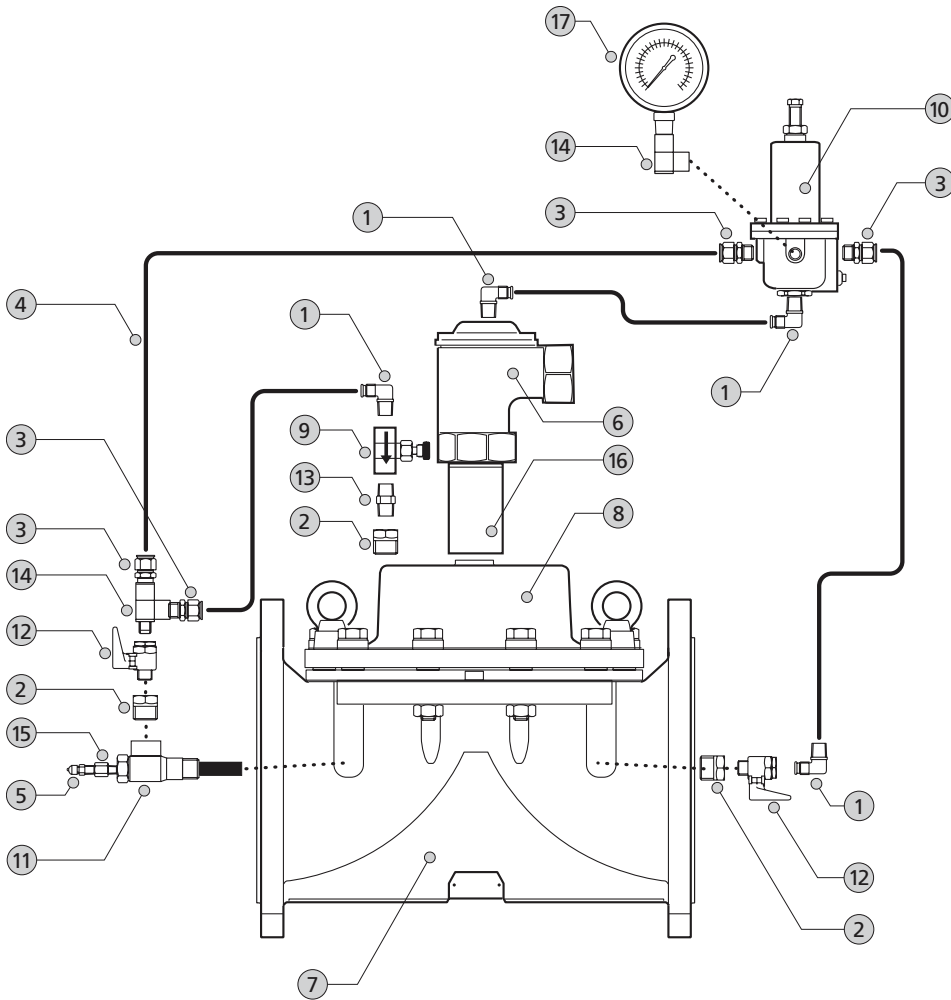

## 6" AND LARGER QR VALVE COMPONENTS

Key	Item Number	Model Number	Qty.	Description
1	78301-001600	55B169PL64	4	Brass Elbow 1/4"
2	78301-003600	55B209P84	3	Brass Bushing 1/2" M x 1/4" F
3	78301-005600	55B68PL64	4	Brass Connector 1/4"
4	71680-018460	55BNB6050	4	Nylon Tubing 3/8"
5	76601-001050	61APS1/8	1	Shrader Valve 1/8"
6	71610-001810	61B2THFSNO	1	2" Galil Valve
7	-	-	1	Basic Valve Body ( <i>based on size, material, connection</i> )
8	71680-009187	61BON6-QR	1	Bonnet for QR Valve
9	77500-004700	61NV1/4	1	Needle Valve 1/4" Brass
10	71680-001265	61PILCXPS	1	Brass Pilot CXPS
11	71680-014100	61SF5	1	Brass Finger Filter 1/2"
12	71610-035600	62SBV25	2	Brass Ball Valve 1/4"
13	78301-003900	55B216P4	1	Brass Hex Nipple 1/4"
14	78301-002000	55B2202P44	1	Brass Street Elbow 1/4" F x 1/4" M
15	78301-003300	55B209P42	1	Brass Bushing 1/4" M x 1/8" F
16	78201-003280	44SNIP2X4	1	Glv Nipple 2"
17	00110-001810	6809020-160	1	Pressure Gauge 0-160 psi

# Troubleshooting

## TROUBLESHOOTING GUIDE FOR 2" QR VALVES

PROBLEM	CAUSE	CHECK	SOLUTION
Valve does not open	Wrong adjustment	Verify upstream pressure	Loosen adjustment bolt on pilot
Valve does not close or leaks	Pilot incorrectly adjusted	Verify upstream pressure	Tighten bolt on pilot
	Punctured diaphragm	Continuous flow at discharge	Replace diaphragm
	Foreign substance on the sealing seat	Dismantle bonnet and inspect	Remove, clean or replace
	Needle valve clogged	Valve stays open	Clean, reinstall and tighten completely
	Finger filter clogged	Valve stays open	Clean, reinstall or replace

## TROUBLESHOOTING GUIDE FOR 3" AND LARGER QR VALVES

PROBLEM	CAUSE	CHECK	SOLUTION
Valve does not open	Wrong adjustment	Verify upstream pressure	Loosen adjustment bolt on pilot
	Ball valves are closed	Verify position	Open ball valves
Valve opens partially	Needle valve wide open	Close fully	Open 1-2 turns
Valve does not close or leaks	Pilot incorrectly adjusted	Verify upstream pressure	Tighten bolt on pilot
	Punctured diaphragm	Continuous flow at discharge	Replace diaphragm
	Foreign substance on the sealing seat	Dismantle bonnet and inspect	Remove, clean or replace
	Needle valve plugged or closed	Water discharges continuously	Open fully and readjust 1-2 turns to open
	Needle valve plugged or closed	Dirt on the sealing seat	Actiate valve and/or clean







**NETAFIM USA**  
5470 E. HOME AVE.  
FRESNO, CA 93727  
CS 888 638 2346  
F 800 695 4753

[www.netafimusa.com](http://www.netafimusa.com)

QRGD 10/10