

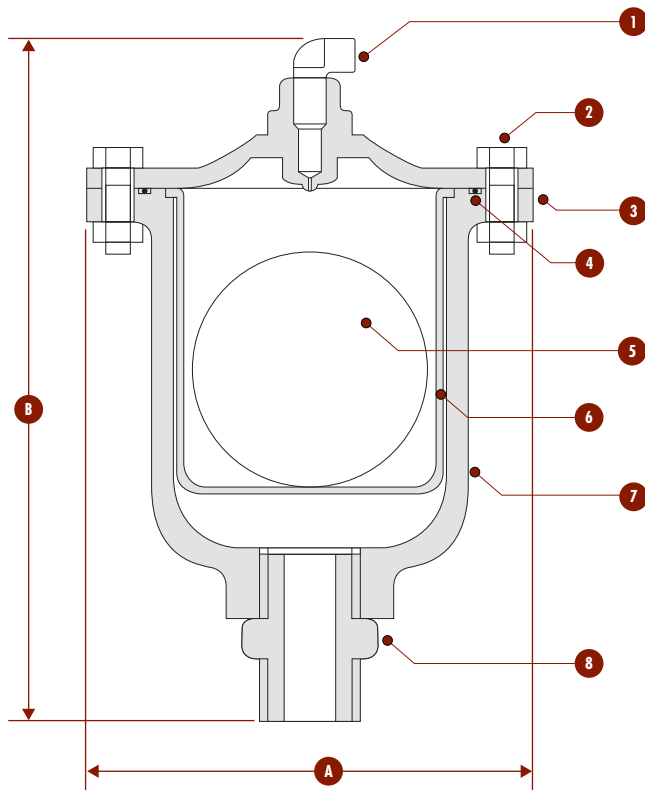

1" Automatic Air Vent

for Copper Mines

Automatic Continuous Acting Air Vent



Parts List and Specifications

No.	Part	Material
1.	Drainage Elbow	Stainless Steel 316
2.	Bolt and Nut	Stainless Steel 316
3.	Cover with Nozzle	Stainless Steel 316
4.	O-Ring	BUNA-N
5.	Float	Stainless Steel 316
6.	Screen Basket	Stainless Steel 316
7.	Body	Stainless Steel 316
8.	Male Adapter	Stainless Steel 316



Applications

- The automatic stainless steel vent screen basket prevents contact between the float and the casting, enabling smoother operation.

Specifications

Stainless Steel SAE 316 body & cover
 Working pressure range: 3-230 psi.
 NPT Threaded

DIMENSIONS AND WEIGHTS

Nominal Size	Dimensions (in.)		Weight (lbs.)	Orifice Area (Sq. In.)
	A	B		
1"	5 7/32	7 27/32	7.7	0.0012

ORDERING INFORMATION

Nominal Size	Part Number	Material
1"	65S0101SS	Stainless Steel

AUTOMATIC AIR Discharge Chart

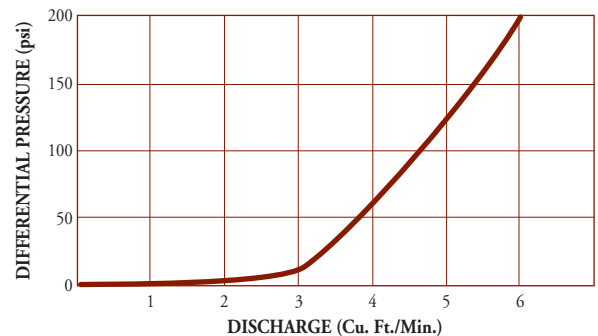

NETAFIM USA
 5470 E. Home Ave. • Fresno, CA 93727
 888.638.2346 • 559.453.6800
 FAX 800.695.4753
www.netafimusa.com M062 5/04